

AAVANTIKA GAS LTD
(A Joint Venture of GAIL & HPCL)

CNG AND CITY GAS DISTRIBUTION PROJECT

BID DOCUMENT

FOR

**LAST MILE CONNECTIVITY (LMC) WORK AT INDORE
GA & UJJAIN AREA**

**AGL/Head Office/Contract and Purchase/11/24-
25/ET/11 [LMC WORK INDS AND COMM]**

VOL II OF II – TECHNICAL



DELIVERS. EVOLVES.

WHOLE LIFE SOLUTIONS FOR PIPELINE AND SUBSEA SYSTEMS



TABLE OF CONTENTS VOL II OF II TECHNICAL

PROJECT: - PROJECT FOR LAYING, TESTING AND COMMISSIONING OF MDPE PIPELINE NETWORK AND INSTALLATION FOR CITY GAS DISTRIBUTION

S.No.	Document Description	Document No.	Revision
1	Scope of Work For Laying, Testing And Commissioning Of MDPE Pipeline	11-0269-02-07-09-001	0
SPECIFICATIONS - MDPE MATERIAL			
2	Execution of Works Installation of Polyethylene Pipes	11-0269-02-07-02-006	0
3	PTS for PE Pipeline - Construction	11-0269-02-07-02-031	0
4	Technical Specification for HDPE	11-0269-02-07-02-032	0
5	Tools & Equipment to be Provided By the Contractor for PE Laying	11-0269-02-07-02-047	0
6	Warning Tape	11-0269-01-07-02-018	0
SPECIFICATIONS – GI MATERIAL			
7	GI Fittings	11-0269-02-07-02-013	0
8	GI Pipes	11-0269-02-07-02-012	0
9	Isolation Ball Valves	11-0269-01-07-02-034	0
10	Appliance Ball Valves	11-0269-01-07-02-035	0
11	Technical Specifications for Installation of Above Ground GI / CU Piping & Fittings	11-0269-02-07-02-033	0
12	Tools and Equipment to be provided contractor for GI/CU Work	11-0269-02-07-02-048	0
SPECIFICATIONS – SAFETY			
13	Standard Specification for health, safety and environment (HSE) management at construction sites	11-0269-01-18-02-037	0
DRAWINGS AND STANDARDS			
14	Polyethylene Pipes for Underground Networks for Natural Gas Distribution General Requirements	11-0269-02-07-02-001	0
15	Polyethylene Pipes for Underground Networks for Natural Gas Distribution-Technical Datasheet	11-0269-02-07-02-002	0
16	Polyethylene Pipes for Underground Networks for Natural Gas Distribution-quality control of Pipes	11-0269-02-07-02-003	0
17	PE Accessories for underground Networks for Natural Gas Distribution	11-0269-02-07-02-004	0
18	Polyethylene Compounds for Manufacture of Pipes and Fittings for Underground Networks for Natural Gas Distribution Acceptance Procedure	11-0269-02-07-02-005	0
19	Supplementary Procedures for Type-Approval of Polyethylene Pipes for Underground Gas Networks	11-0269-02-07-02-007	0
20	Powder Coating	11-0269-02-07-02-014	0
21	Technical Specification for Polyethylene Pipes	11-0269-02-09-02-024	0
VOLUME II OF III TABLE OF CONTENTS			
		DOCUMENT NO.	REV
		11/0269/WGI/AGL/09-R0	0
SHEET 1 OF 2			

DRAWINGS			
1	RCC Pit for PE Stop-Off Valve (Dia. 32 mm)	AGL/LMC/32/1	0
2	Regulator Box Brackets & Clamps	WGI-01-P-0-103	B
3	Standard Detail for Warning Plate Marker W/O Foundation	WGI-01-P-0-101	B
4	Typical Trench Details for City Gas Distribution	WGI-D-19-005	1
5	RCC Pit for PE Stop-Off Valve (Dia. 125)	STD-19-142	1
6	RCC Pit for PE Stop-Off Valve (Dia. 63 & 32mm)	STD-19-142	2
7	SFRC Cover for PE Stop-Off Valve PIT	STD-19-144	2
8	C.I Frame for SERC Cover of PE Stop-Off Valve PIT	STD-19-145	2
9	Road / Highway Cased Crossing for MDPE PIPE	WGI-01-P-102	B
10	Barricading	STD-19-146	0
11	Safe Signing	STD-19-147	0
12	Reinforcement for Excavation Closer to RCC Road side	STD-19-149	0
13	Typical Trench / Reinstatement Details	STD-19-152	0
14	Underground Cable Crossing	STD-19-006	1
15	Existing Underground Pipe Crossing (Type-II)	STD-19-023	3
16	Existing Underground Pipe Crossing (Type-I)	STD-19-022	2
17	Pipe Line Warning Sign	STD-19-015	0
18	Typical Row Boundary Marker	STD-19-017	0
19	Typical I&C GI Installation Drawing	AGL-TS/PE Type/ 17	0
20	RCC Guard for TF protection	AGL-TS/PE Type/ 16	0
21	Existing above ground pipe crossing	STD-19-026	1
VOLUME II OF III TABLE OF CONTENTS		DOCUMENT NO.	REV
		11/0269/WGI/AGL/09-R0	0
		SHEET 2 OF 2	

**AAVANTIKA GAS LIMITED
CITY GAS DISTRIBUTION PROJECT**

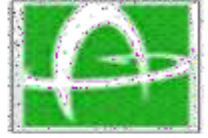

SCOPE OF WORK FOR LAYING, TESTING AND COMMISSIONING OF MDPE PIPELINE					CLIENT JOB NO.		
					TOTAL SHEETS		08
DOCUMENT NO	11	0269	02	07	09	001	

--	--	--	--	--	--

0	18.10.09	ISSUED FOR CLIENT COMMENTS	AP	SB	SB
A	16.10.09	ISSUED FOR IDC	AP	SB	SB
REV	DATE	DESCRIPTION	PREP	CHK	APPR

TABLE OF CONTENTS

1.0 GENERAL..... 1

2.0 SCOPE OF WORK 1

3.0 FREE ISSUE BY AGL.....4

4.0 PROJECT SCHEDULING.....4

5.0 MONITORING4

6.0 QUALITY ASSURANCE SYSTEM5

7.0 EXCESS MATERIAL AND SCRAP (OWNER FREE ISSUE) 5

8.0 DRAWINGS TO BE SUPPLIED BY THE OWNER..... 6

	SCOPE OF WORK FOR LAYING, TESTING AND COMMISSIONING OF MDPE PIPELINE	DOCUMENT NO.	Rev
		11-0290-02-07-09-001	0
	Page 2 of 8		

1.0 GENERAL

M/s AGL intends to float tender for laying, testing and commissioning of MDPE pipeline network and installation of above ground GI/Copper including connection to industrial houses & commercial establishments at in cities of Indore.

The detailed scope of work by the Bidder includes in general to complete lowering, laying, jointing, inspection, testing, pre-commissioning, commissioning and performance testing along with all associated works pertaining to complete premises, totally conforming to the General Technical Specifications, Particular Technical Specifications, Drawings, Data sheets and other information provided in this document. All materials either supplied by the owner or supplied by the contractor shall be included in the scope of erection/ construction of the contractor. It must be clearly understood that each and every system of this project should be completed by the contractor in all respects, including supply of material, so that the project is commissioned and made operational without any shortcomings.

No extra claims or variations related payments will be allowed for items or activities which are required to complete the pipeline system and make it fully operational as per the Scope of Work defined in the Bidding Document.

DEFINITIONS

CLIENT / OWNER	:	Aavantika Gas Ltd
CONTRACTOR	:	The person, firm or company on the Purchase Order and to whom the Purchase Order is addressed.
VENDOR	:	“Vendor” means the person(s), firm, company, organization from whom contractor procures products/services.

2.0 SCOPE OF WORK

The scope of work is broadly divided in to the following:

- Construction
 - Pre-commissioning and Commissioning
 - Project Management
- Vendor will have to upload scan copies of all the documents like RFC report, site verification records like graphs, isometrics, job card etc. at AGL's Vendor Portal for which each vendor will be provided distinct user id and password.
- Installation of TF / GC work will also to be carried out.

2.1 Construction & commissioning of PE 100 Pipeline.

2.2 The service connection downstream of pipeline for commercial customer & Industrial connection. This includes supply and installation of aboveground GI pipes, fittings and valves as per attached sketches and specifications. All above ground valves for I&C connections shall be as per attached specification. GI ball valves as required and its supply shall be in the scope of bidder for I&C connections are as defined below:

1. Isolation ball valve at Up-stream of every commercial & Industrial (I&C) regulator.
2. Isolation ball valve at down-stream of every commercial & Industrial (I&C) regulator and up stream of I&C Connections.
3. Ball valve (including Stop-Plug) at down-stream of every I&C meters.

	SCOPE OF WORK FOR LAYING, TESTING AND COMMISSIONING OF MDPE PIPELINE	DOCUMENT NO.	Rev
		11-0290-02-07-09-001	0
		Page 3 of 8	

Please note that measurement for GI installation will be in running meter only. No separate payment will be given for Valves and fittings.

- 2.3 Installation of DRS/MRS / Metering Skid for Commercial and Industrial connections. Laying, installation of Steel Piping above ground at DRS/ MRS/ Metering station for hook- up of DRS/MRS / Metering Skid with existing pipeline. For steel piping, all the welding works shall be carried out by approved steel line Contractor or approved workshop. Approval before finalization of sub- contractor or workshop shall be taken by contractor from OWNER/ Owner's Representative. Before start of steel piping procedures for welding and welder qualification shall be submitted by contractor to OWNER/ Owner's Representative. Welding shall be carried out only by the approved welder. Welding shall be start only after getting approval from OWNER/ Owner's Representative.
- 2.4 Laying of PE 100 Pipeline with proper road reinstatement (wherever required) from District Regulating station as per attached route map with the bid document. This includes trenching, electro fusion welding, pipe laying, back filling & restoration, testing, nitrogen purging, commissioning of pipeline and submission of as laid drawing duly accepted by OWNER/ OWNER's Representative.
- 2.5 All materials, equipment, trailers for transportation, loading, unloading, stringing etc. for Owner's supplied material.
- 2.6 Supply and laying of Casing pipes.
- 2.7 All equipment and material for excavation.
- 2.8 All equipment, pumps for dewatering, any temporary arrangement etc.
- 2.9 All materials, equipment required for repair/restoration of pavements, roads, bunds, other structures affected/damaged by Contractor's construction activities. Materials shall be equivalent/superior to those used for original construction of the facility.
- 2.10 Permanent reinstatement of trenches excavated by the contractor as a part of scope of work, wherever required, to the satisfaction of Owner/Owner's Representative / concerned authorities having jurisdiction.
- 2.11 Co-ordinating & obtaining approval for excavation, boring, crossing etc. from various authorities / agencies having jurisdiction. The client shall provide in principle approval.
- 2.12 Submission of Auto Cad drawings for work executed.
- 2.13 Provision & Maintenance of proper stores.
- 2.14 Maintaining the network till the completion of work.
- 2.15 Construction of PE Valve chamber including supply of all materials as per OWNER'S/ Consultant approved drawing. This also includes supply of frame and cover of valve chamber by the Contractor. The Chamber cover shall be pre-cast only of M-35 strength conformed to IS 456-1978. Vendor to provide test certificate and shall be inspected by PMC/AGL. Cast-in-situ not allowed. Cleaning all unserviceable materials, debris and excess earth trench etc.to designated disposal area.
- 2.16 Installation of PE valves, fittings and all accessories & carrying out electro fusion welding with pipeline.
- 2.17 Tie-in of the Medium Pressure 4 bar PE 100 network with District Regulating System by using transition fittings.
- 2.18 Testing with air or nitrogen of entire network. Arrangement of compressor and other related accessories for successful completion of testing shall be in the scope of contractor.
- 2.19 Nitrogen purging and achieving less than 2% O₂ in entire network. Arrangement of nitrogen cylinder and O₂ detector instrument shall be in the scope of contractor.
- 2.20 Methane detector for ensuring Gas in the network shall be in the scope of work.
- 2.21 Any kind of defect except manufacturing defect in owners supplied material that occurs during handling, storage, loading, unloading, construction of pipeline shall be repaired/replaced by contractor, Owner reserves the right to recover the amount from Contractor's payment in case of a non compliance.

	SCOPE OF WORK FOR LAYING, TESTING AND COMMISSIONING OF MDPE PIPELINE	DOCUMENT NO.	Rev
		11-0290-02-07-09-001	0
		Page 4 of 8	

- 2.22 Any manufacturing defect in owners supplied material to be detected during testing and commissioning shall be attended / replaced by contractor.
- 2.23 Equipment, components, consumables, etc. required for temporary and permanent installation and for completion of network.
- 2.24 Consumables and Spares required for Construction, Pre-commissioning and commissioning/ Startup.
- 2.25 Ensuring adequate quality assurance and control including stage wise inspection, testing and certification. Dedicated QC person to be deployed for each spread.
- 2.26 Supply of all the material required for execution and installation, detailed in scope of work except material listed in cl. 3.0 of Scope of Work of this tender document.
- 2.27 Contractor shall procure & supply all other materials so as to complete the work as per requirements of bid document within his quoted rates. The indicative list of major material in the scope of contractor is identified below. The contractor should understand that this list is only indicative and not exhaustive and as such the contractor shall include the item not covered but required for execution of works in his scope. Any other material required for successful construction & completion of work has to be taken care of by the contractor. Owner / Consultant shall not be responsible for any omission / deletion in the list which is required for completion of the work.

S. No	Item
1.	Sand
2.	Warning Tapes
3.	Markers
4.	Warning Sign Boards
5.	Safety Barricades
8.	GI Fittings and GI Valves
9.	Copper Pipes, Copper fittings
10	Crimping Guards

- 2.28 All material required to be supplied by Contractor for the scope of work as mentioned above shall be procured as per technical specification attached with the bid document and approval of the Owner/Consultant. The contractor shall procure material from approved vendors list. Stage wise and final inspection at vendor's works and contractor's stores may be carried out by contractors approved TPI and final inspection by owner/ owner's representative.
- 2.29 Owing to the technical requirements or otherwise, OWNER reserves the right to amend/vary/modify the material requirement and/or specification at any time during the period of the Contract.
- 2.30 OWNER has provided the specifications for the material in the scope of the Contractor for procurement and use. However, in case, due to omission or otherwise, any specification is not provided, the contractor would approach the OWNER and obtain the specifications in writing prior to the actual procurement and use of the material. It may be noted that considering the safety aspects, OWNER would approve the specifications of all material to be used for the execution of the contract.

	SCOPE OF WORK FOR LAYING, TESTING AND COMMISSIONING OF MDPE PIPELINE	DOCUMENT NO.	Rev
		11-0290-02-07-09-001	0
		Page 5 of 8	

All material test certificates, internal inspection reports, release notes and other relevant certificates / documents must be furnished by contractor and verified by concerned authority of OWNER before actual use of respective material in project.

3.0 FREE ISSUE BY AGL

Pipes

PE Valve

Meter Skid

Meter

Regulator

AGL will not supply any material to Contractor as Free Issue except as above. Receipt, transportation including loading and unloading from Owner’s premises, handling, storage, and erection and commissioning of such ‘Free Issue’ material is in the Contractor’s Scope of Work.

4.0 PROJECT SCHEDULING

4.1 CONTRACTOR shall provide schedule with bar charts within 15 (fifteen) days of receiving of notification of award of CONTRACT, covering the Scheduled Status of all functions of the project like procurement, construction and commissioning phases. This network shall be reviewed and approved by the OWNER/OWNER’S REPRESENTATIVE and the agreed network shall form the basis of scheduling and monitoring.

4.2 CONTRACTOR shall prepare functional schedules and resource based bar charts with Scheduled progress curves of all the disciplines for the following:

- Procurement Schedule:

The schedule for each material requisition from enquiry to receipt at site shall be given.

- Construction Schedule:

The schedule for identical type of items shall be grouped under each discipline for each unit. The man-hours required for construction of these items shall form the basis of weightages. Planned resource deployment to suit these schedules shall also be provided.

5.0 MONITORING

5.1 The CONTRACTOR at his own cost will submit following reports in agreed formats and frequency.

- i. Progress Report to be submitted every fortnight and inform site office of OWNER/ Consultant within 5 days. This report shall include progress Bar charts (Procurement, Constructions & overall progress), executive summary, hold-ups and slippage, salient features, status of important milestones, detailed activity description done during the fortnight, resource deployment, areas of concern.
- ii. Daily & Weekly Construction Progress Reports.
- iii. Equipment & Manpower deployment status Reports.
- iv. Drawing Status Reports (Fortnightly).
- v. Material Status Reports (Fortnightly).
- vi. QA & QC Reports (Fortnightly).
- vii. Safety Reports (fortnightly).
- viii. Material Reconciliation Reports.

	SCOPE OF WORK FOR LAYING, TESTING AND COMMISSIONING OF MDPE PIPELINE	DOCUMENT NO.	Rev
		11-0290-02-07-09-001	0
		Page 6 of 8	

6.0 QUALITY ASSURANCE SYSTEM

6.1 The CONTRACTOR shall establish documents and maintain an effective quality assurance system as outlined in specifications and shall submit the same to OWNER/OWNER'S REPRESENTATIVE for approval. Quality plan/procedures shall be furnished in the form of QA manual. This document should indicate organizational approach for quality controls and assurance of the works also provide objective, verifiable evidence that they have carried out all activities for the purpose followed and specifications as laid down in the tender and procedures. This document should cover details of the personnel responsible for the Quality Assurance, Plans and Procedures to be followed for quality control in respect of Procurement, Supply, Installation, Testing and Pre-commissioning etc.

6.2 Quality Control Plans showing the details of all the activities to be examined by Quality Control Department of the CONTRACTOR and also the activities which are proposed to be inspected by inspection agency of the CONTRACTOR appointed with due approval of the OWNER, and inspecting agency independently appointed by OWNER/OWNER'S REPRESENTATIVE, along with the documentation which shall be maintained and submitted to the OWNER. Quality Control should indicate the following details:

6.2.1 Check Points/measuring instruments with capacity/accuracy/range.

6.2.2 Quality control and Quality Assurance Organizational set-up proposed to be deployed by the CONTRACTOR.

6.2.3 Procedure for test/calibration/maintenance of instruments/equipment.

6.2.4 Quality control and Quality Assurance Procedure in case a portion of work or supply is being carried out by a SUB-CONTRACTOR/specialized agency.

7.0 EXCESS MATERIAL AND SCRAP (OWNER FREE ISSUE)

7.1 Every month, the Contractor shall submit an account for all the materials issued by the Owner's Representative. On completion of the work, the Contractor shall submit "Material Appropriation Statement" for all materials issued by the Owner.

7.2 Scrap permissible allowances for pipes shall be 2% for MDPE. The percentage allowance shall be accounted on the basis of certified final as-built length for main pipeline.

7.3 For the purpose of accounting of pipes, all cut pieces measuring in length of 2M for MDPE and above when returned to Owner's storage points after end facing, shall be treated as salvageable material. All pipes measuring less than 2 meters for MDPE will be treated as wastage/scrap.

7.4 All unaccountable free issue materials supplied by Owner shall be charged to the Contractor on landed cost with 200% of overheads.

7.5 All unused material shall be the property of the Owner and shall be returned by the Contractor at his cost to the designated storage points. Contractor shall be responsible for proper weighing / measurement of the surplus materials to be returned to the store.

All serviceable materials shall be segregated as per quality and specification and returned to Owner separately with proper identification.

8.0 DRAWINGS TO BE SUPPLIED BY THE OWNER

8.1 The drawings accompanying the tender document are indicative of nature of work and issued for tendering purpose only. Purpose of these drawings is to enable the tenderer to make an offer in line with requirements of the Owner. List of Drawing is appended to Scope of work. During construction Owner will

	SCOPE OF WORK FOR LAYING, TESTING AND COMMISSIONING OF MDPE PIPELINE	DOCUMENT NO.	Rev
		11-0290-02-07-09-001	0
	Page 7 of 8		

issue the detailed drawings “Approved for Construction” with all details of facilities. However, no extra claim whatsoever shall be entertained for any variation in the “Approved for Construction” and “Tender Drawings” regarding any changes/units. Construction shall be as per drawings/specifications issued/approved by the Owner’s Representative during the course of execution of work.

Detailed construction drawings on the basis of which actual execution of work is to proceed will be furnished to the Contractor progressively based on the detailed construction program evolved after the award of work and also based on construction progress achieved.

- 8.2 Detailed working drawings on the basis of which actual execution of the works is to proceed, will be furnished from time to time during the progress of the work. The Contractor shall be deemed to have gone through the drawings and bring to the notice of the Owner’s Representative discrepancies if any, therein before actually carrying out the work.
- 8.3 Copies of all detailed working drawings relating to the works shall be kept at the Contractor’s office on the site and shall be made available to the Owner’s Representative at any time during execution of the Contract. The drawings and other documents issued by the owner shall be returned to the Owner on completion of the works.

	SCOPE OF WORK FOR LAYING, TESTING AND COMMISSIONING OF MDPE PIPELINE	DOCUMENT NO.	Rev
		11-0290-02-07-09-001	0
	Page 8 of 8		

**AAVANTIKA GAS LIMITED
CITY GAS DISTRIBUTION PROJECT**

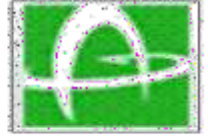

**EXECUTION OF WORKS INSTALLATION OF POLYETHYLENE
PIPES**

CLIENT JOB NO.

TOTAL SHEETS

24

DOCUMENT NO

11

0269

02

07

02

006

--	--	--	--	--	--

REV	DATE	DESCRIPTION	PREP	CHK	APPR
0	18.10.09	ISSUED FOR CLIENT COMMENTS	AP	SB	SB
A	16.10.09	ISSUED FOR IDC	AP	SB	SB

EXECUTION OF WORKS INSTALLATION OF POLYETHYLENE PIPES

	EXECUTION OF WORK-	DOCUMENT NO.	Rev
	INSTALLATION OF	11-0269-02-07-02-006	0
	POLYETHYLENE PIPES	Page 2 of 24	

TABLE OF CONTENTS

1 INTRODUCTION 4

2. DEFINITIONS 4

3. MATERIALS 5

4. EARTH WORKS..... 5

5. HANDLING OF PIPES AND COMPONENTS BEFORE AND DURING LAYING 7

6. FUSION WORK, FUSION JOINTS 10

7. TESTS 16

8. NON-FUSION JOINTS 21

9. CATHODIC PROTECTION 21

10. SPECIAL WORKS 21

ANNEXURE - 1..... 24

	EXECUTION OF WORK-	DOCUMENT NO.	Rev
	INSTALLATION OF	11-0269-02-07-02-006	0
	POLYETHYLENE PIPES	Page 3 of 24	

The information contained in this document should be treated as confidential and is to be considered as the exclusive property of WGI.

Direct or indirect use of this document or any part of it is only allowed for WGI productions.

1 INTRODUCTION

This specification defines the requirements which must be met for the installation of polyethylene pipes for natural gas distribution.

Deviations from this specification are only permitted if they have been explicitly permitted by the Owner/Consultant due to local circumstances and subject to the required precautions being taken.

2. DEFINITIONS

2.1. PRESSURE

Pressure referred to in this document is measured above atmospheric in bar. 1 barg = 1000 mbar above atmospheric pressure. (barg = bar gauge)

2.2. LP - LOW PRESSURE

Pipelines with a normal operating pressure not greater than 1 barg.

2.3. MP - MEDIUM PRESSURE

Pipelines with a service pressure greater than 1 barg but not greater than 19.8 barg.

MP A: pipelines with a maximum operating pressure between 1 barg and 5 barg.

MP B: pipelines with a maximum operating pressure between 5 barg and 19.8 barg.

2.4. LCL - LOWER CONFIDENCE LIMIT

A quantity, expressed in megapascals (MPa), representing the material stress which corresponds to the reliability limit of 97.5% of the specified long-term hydrostatic strength (LTHS) for a period of 50 years, calculated according to ISO 9080.2.

2.5. MRS - MINIMUM REQUIRED STRENGTH

MRS 10: standardized class of compounds for which the LCL is equal to 10.

2.6. PE 100

Standard designation for PE compounds in class MRS 10.

For such PE compounds, the long-term hydrostatic strength — calculated and classified according to the standardized method (ISO 9080 and ISO 12162) for a temperature of 20°C, a period of 50 years and a reliability of 97.5 % — must be at least 10 MPa.

2.7. SDR

The number SDR giving the ratio of the nominal diameter d in relation to the nominal wall thickness (e) .

	EXECUTION OF WORK-	DOCUMENT NO.	Rev
	INSTALLATION OF	11-0269-02-07-02-006	0
	POLYETHYLENE PIPES	Page 4 of 24	

2.8. OD - NOMINAL OUTSIDE DIAMETER

Nominal outside diameter of the plastic pipe or fitting (also referred to as *d*)

3. MATERIALS

3.1. NATURE OF THE MATERIALS

The pipes and fittings (T-pieces, elbows, reductions etc.) which form part of the gas pipelines are made of polyethylene.

The pipes used satisfy standard prEN1555 1 and 2 and WGI additional technical specifications (11-0269-02-07-02-001, 11-0269-02-07-02-002, 11-0269-02-07-02-003, 11-0269-02-07-02-004, 11-0269-02-07-02-005 & 11-0269-02-07-02-007). They are made of polyethylene with classification of MRS 10 (PE 100). Pipes and fittings can be supplied in two different wall thicknesses standardized according to the SDR series SDR11 or SDR17.6.

The correct material to be chosen with respect to raw material, MRS, SDR, color, packaging and marking is laid down by the Owner/Consultant and may vary according to the circumstances. The Contractor will if necessary adapt his welding technology according to the choice referred to above. Only welded joints are permitted as a standard. Exceptions to this require the express permission of the Owner/Consultant.

Fittings made of other materials shall be in accordance with the standard concerned for use in gas pipelines.

3.2. MATERIALS MADE AVAILABLE BY THE OWNER

Unless otherwise specified, the materials stated below are made available to the Contractor by the Owner at its warehouses.

3.2.1. MDPE pipes of all sizes that is 125mm, 63mm, 32mm & 20mm.

3.2.2. MDPE fittings of all sizes & valves of all sizes except those specified in the scope of contractor.

3.2.3. DRS/ MRS

All materials which are not mentioned in section 3.2. are supplied by the Contractor and shall be included in the unit prices offered in the Tender.

If they do not meet the quality requirements or other criteria in connection with the expert execution of the work or the provisions of the specifications, the Owner is entitled to reject the materials supplied by the Contractor - even after they have been installed - and shall be replaced without any cost implication to owner.

4. EARTH WORKS

4.1. ADDITIONAL PROVISIONS

4.1.1. Laying Depth

This is the vertical distance between the top tangent of the pipeline and the top level of the expertly repaired road surface.

	EXECUTION OF WORK-	DOCUMENT NO.	Rev
	INSTALLATION OF	11-0269-02-07-02-006	0
	POLYETHYLENE PIPES	Page 5 of 24	

At a crossing with railways, this is the vertical distance between the top tangent of the pipeline and the lowest rail foot.

If the pipeline is in a sleeve, the lying depth is determined with respect to the top tangent of this sleeve.

4.1.2. Cover

Unless otherwise stated, the following covers apply to the various pressure classes:

Pressure	Normal Cover	Crossings	
		Express road motorways	Railways *
LP	1.0 m	1.2 m	1.7m
MP	1.0 m	1.2 m	1.7m

* The depth shall be as defined in the permissions accorded by Railway / Competent Authorities. In case it is impractical to provide covers as defined above due to physical constraints, additional protective measures such as concrete slabs or high impact resistance plastic sheets shall be installed at least 300mm above the service line. In no case the depth of cover shall be less than 600mm.

4.1.3. Mutual spacings

If the underground pipeline is laid in the vicinity of other underground works, a distance of 0.1 m must exist at the intersections or 0.2 m in the case of parallel running between the most adjacent parts of the two installations. Wherever possible, these distances are increased, in particular in the vicinity of large engineering structures, in order to limit as far as possible for each installation the risks associated with carrying out work on a nearby installation.

If the minimum distances stipulated in this section cannot be complied with or if the nature of the products transported in the other underground pipelines necessitates (such as steam pipelines or district heating), the Contractor will take special precautions. These precautions comprise in each case doubling the distances or interposing an additional adjusted isolating screen which can consist of a rubber mat laid double, 5 mm in thickness (quality in accordance with the specification). The screen must be secured to the pipe in an efficient way to prevent displacements. In the event of two pipelines crossing, the screen will have a minimum length of 0.5 m.

It should be ensured that these distances are not achieved by twisting or treating incorrectly one of the underground pipelines.

4.1.4. Trench adjustments

Contractor shall maintain a minimum trench width of 300mm. The bed of the trench shall be free of sharp objects, stones etc. In rocky areas trench shall be provided with soft soil or sand to minimum depth of 150mm below the pipe. The Contractor shall carry out the necessary trench widening and trench deepening at no extra cost at the following places:

	EXECUTION OF WORK-	DOCUMENT NO.	Rev
	INSTALLATION OF	11-0269-02-07-02-006	0
	POLYETHYLENE PIPES	Page 6 of 24	

- On the fusion joints where these are made in the trench;
- At the places where destructive or non-destructive testing has to be performed;
- Wherever necessary because of the local circumstances and the execution of work.

4.2 EXCAVATION AND BACKFILLING OF TRENCHES

Local codes of practice are to be followed.

Among others:

- Technical requirements for Laying of New Major Services within the Road Reserve (Version 5).
- Code of Practice for Road-Opening Works.
- Code of Practice for temporary Traffic Controls.

5. HANDLING OF PIPES AND COMPONENTS BEFORE AND DURING LAYING

5.1. HANDLING OF PIPES OR PIPELINES

5.1.1. It is compulsory:

- to take the necessary precautions to prevent damage during the loading, transportation, unloading and various other operations involving the handling of pipes and fittings;
- to stack the pipes on a flat surface and to support and clamp them sufficiently during transport;
- to organize the movement of the pipes so that the pipe or the ends of it do not drag across the ground.

5.1.2. It is prohibited:

- to roll pipes across the ground or the road surface;
- to lift up or move pipes or pipelines with cables, chains or other hard or squeezing ropes;
- to bring the pipes into contact with a naked flame, oil or bituminous products.

5.2. ACTIONS PRIOR TO FUSION

The pipes and fittings are carefully checked immediately prior to fusion.

Internal check

for the presence of foreign objects (such as tools, earth, stones etc.), which must then be removed carefully.

The Owner/Consultant might require that a suitable brush be drawn through every pipe.

External check

For any damage, however slight.

In the case of damage deeper than 1 mm, the damaged part should be removed.

5.3 PIPE ARRANGEMENT DURING FUSION

Lengths can be fused together, depending on the local circumstances, above or alongside the trench. The actions for laying the pipeline in Cl. 5.1 and 5.2 apply to installing the pipeline sections fused together in the trench.

	EXECUTION OF WORK-	DOCUMENT NO.	Rev
	INSTALLATION OF	11-0269-02-07-02-006	0
	POLYETHYLENE PIPES	Page 7 of 24	

5.4. TEMPORARY SEALING OF PIPELINE ENDS

5.4.1. Every pipeline which is temporarily left alongside or above the trench shall always be protected against the penetration of water, dust or any objects by means of plugs or caps. Special attention shall be paid to these plugs while towing the pipeline in the trench.

The plugs or caps are designed in such a way that they cannot enter the pipeline and can be easily removed.

A necessary number of plugs or caps, matched to the various diameters of the pipelines to be laid, should always be available.

5.4.2. Ends of pipelines temporarily left behind in the trench must be sealed in such a way that it is impossible for water or mud to penetrate, even if the trench runs completely under water. Suitable plugs or caps shall be necessarily used for this purpose.

5.4.3. The presence of water or dirt in the pipeline is regarded as a serious fault of the Contractor. In such cases the Owner/Consultant will oblige the Contractor to clean the pipeline, at his own expense, with a pipe cleaner until all the water and dirt have been removed.

5.5. ACTIONS BEFORE LAYING IN THE TRENCH

Immediately before a pipe or a fused section of pipeline is left in the trench, the Contractor shall:

5.5.1. Inspect the condition of the bottom of the trench thoroughly again, work away the unevenness's where necessary and remove all earth, stone, sharp objects etc. In rocky areas trench shall be padded with soft soil or sand to a minimum depth of 150mm below the pipe.

5.5.2. Carry out a last careful check on the good condition of the pipelines.

5.6. CROSSINGS OF ROADS AND ENGINEERING STRUCTURES

Crossings of roads and engineering structures shall be designed so as to minimize the number of joints.

5.7. INSTALLATION IN THE TRENCH

All necessary precautions must be taken in order to avoid pipe damage during installation.

The Owner/Consultant must be notified of any damage.

Any damage to the groove of the butt fusion weld leads to rejection: the weld must then be cut out and done again.

5.8 UNCOILING AND INSTALLATION OF COILED PIPES

- General

- The tensile force on the pipe must be as low as possible.

	EXECUTION OF WORK-	DOCUMENT NO.	Rev
	INSTALLATION OF	11-0269-02-07-02-006	0
	POLYETHYLENE PIPES	Page 8 of 24	

- The rotational speed of the reel during uncoiling must be kept under control.
- The pipe must be uncoiled along the lower edge of the reel, at a tangent to the turns. This prevents the spiral effect, which makes correct installation impossible.
- The outer surface of the pipe is examined during uncoiling. Grooves more than 1 mm deep, kinks in the pipe wall, the inclusion of foreign objects or any other visible deviation are reported to the Owner/Consultant. The latter will decide whether the section of pipe concerned is to be removed.
- Rollers must be laid on the bottom of the trench across the complete length of the route; their number is chosen such that the pipe cannot scrape across the ground at any time; they are also installed in order to prevent twisting of the pipe against obstacles; the same happens in elbows, the radius of curvature of which is greater than 20 times the diameter of the pipe.

Manual towing

- If the trench can be opened over its entire length, and no obstacles are present, the pipe may be uncoiled directly in the trench. The reel is placed for this purpose on an uncoiling truck, which travels slowly along the trench.
- If obstacles block the trench in the part where the pipe has to be laid, the uncoiling truck remains in position and the pipe is pushed over the obstacles manually. The pipe must be supported by sufficient people so that it is laid down and not dragged.

• Mechanical towing

The winch for towing must be approved by the Owner/Consultant before actual start of work.

It must allow gradual towing so that the pipe is uncoiled regularly and without shocks; the maximum permitted uncoiling rate is 15 m/minute.

It must be equipped with a dynamometer and be provided with an adjustable force limiter which automatically stops the towing as soon as the maximum selected tensile force has been reached. The Owner/Consultant may require a recent calibration report on the dynamometer before towing is started; this report must have been certified by a recognized inspection body.

It must also be provided with a device for measuring the tensile rate and a recording device which prints out the tensile force exerted on the pipe during installation as a function of the pipe length. This graph, on which the designation of the section of pipeline is indicated, is handed over to the Owner/Consultant.

	EXECUTION OF WORK-	DOCUMENT NO.	Rev
	INSTALLATION OF	11-0269-02-07-02-006	0
	POLYETHYLENE PIPES	Page 9 of 24	

The tensile force which is exerted on the pipe must be kept as low as possible; it may in no case exceed the values shown below:

MAXIMUM TENSILE FORCE ON PE

PIPE The values given are based on the following formula:

$$F = \sigma_n (3.14) d_e^2 / 3SDR$$

σ_n = nominal wall tension in the PE pipe (± 15 N/mm²)

d_e = nominal diameter of the PE pipe

SDR = SDR series of the pipe (see definitions)

The adjustable force limiter may be replaced by the assembly described below when the towing cable is attached to the PE pipe:

A metal cap is placed over the pipe; this cap is provided with two holes 29 mm in diameter, 180 degrees apart. After the cap has been pushed over the pipe, two holes 28 mm in diameter, also 180 degrees apart, are drilled in the pipe wall at a distance from the edge of *c* mm. A bolt with a nut is secured through these, so that the cap is firmly connected to the pipe. The dimension *c* is chosen such that in the event of excessive tensile force this part of the pipe cracks and thus detaches the PE pipe from the cap.

VALUE OF C		
d.	SDR 17	SDR 11
32	-	4 mm
63	-	8 mm
125	10 mm	10 mm

The last 0.3 m of the pipe end to which the towing cable has been attached must be cut off afterwards.

6. FUSION WORK, FUSION JOINTS

6.1. COMPETENCE REQUIREMENTS FOR FUSION OPERATORS

All fusion operators must have satisfied both the draft International Standard ISO/DIS/19480 "training and assessment of fusions operators" drawn up by the "Fusion Operators" working group ISO TC 138/SC4

	EXECUTION OF WORK-	DOCUMENT NO.	Rev
	INSTALLATION OF	11-0269-02-07-02-006	0
	POLYETHYLENE PIPES	Page 10 of 24	

and the Owner/Consultant's acceptance procedure, after a training course which comprises at least the following parts:

- generalities on polyethylene pipelines for gas.
- butt fusion technology and/or electrofusion technology has been attended.

The fusion operator shall be qualified and should have previous experience of doing similar joints. A certificate shall be issued by the Owner/Consultant, which shall be valid for one year based on the qualification of the operator. The certificate or the recognition does not absolve the Contractor of his responsibilities in the event of accidents or damage caused by the fusion operator concerned. The certificate must be extended annually subject to an evaluation of the person concerned. This evaluation takes place with the fusion equipment of the person concerned. The qualification must relate to the technology applied (butt and/or electrofusion). Fusion operator preferably shall have successfully carried out electro fusion joints. Each recognized fusion operator shall be in the possession of identification markers, with which he identifies the weld carried out by him on the pipe, next to the weld. Each recognized fusion operator shall be in the possession of an operator's badge designed in a form of a bar code card as specified in the standard ISO 12176-3.

6.2. EXECUTION OF THE FUSION WORK

- PE pipelines for all diameters shall be necessarily joined by the electro fusion technique. Jointing of plastic piping by butt fusion method, solvent cement method, adhesive method, heat flux method or by means of compression couplings or flanges is not permitted.
- Mechanical assemblies can only be performed on the instructions of the Owner/Consultant.

6.2.1 Fusion equipment

All fusion equipment used must be presented to the Owner/Consultant for approval. It must additionally satisfy:

- For electrofusion machines: As per the ISO Standard 12176-2 and the Owner/Consultant specification, if any.

Without the written agreement of the Owner/Consultant, only polyvalent equipment which allows fusion voltages in the range from 8 to 48 V and for which the fusion procedures can be entered using a bar code reader and/or magnetic card reader may be used. All electro fusion fittings shall be bar coded and the control unit shall be equipped with bar code reader to directly transfer fusion data to control unit. Bar coding shall be long lasting even when the joint is buried in corrosive soil.

The fusion machines must comply with all the applicable safety regulations. The Owner/Consultant reserves the right to have a technical inspection carried out at its expense.

All equipment must be subjected to an annual inspection by the Owner/Consultant or an accepted inspection body by the manufacturer with regard to electro fusion equipment. Contractor shall arrange for inspection of such annual inspection in consultation with Engineer-In-Charge.

	EXECUTION OF WORK-	DOCUMENT NO.	Rev
	INSTALLATION OF POLYETHYLENE PIPES	11-0269-02-07-02-006	0
	Page 11 of 24		

Every item of equipment subjected to such inspection shall be provided with a mark or certificate.

The testing body will apply a green sticker to every approved machine and/or part, and a red sticker to rejected items. In the case of butt fusion machines, these are the basic carriage, the hydraulic system, the plane, the heating mirror and the gripping jaw.

Electrofusion machines are marked by the manufacturer either externally or in the electronic memory which is clarified by the welding reports.

If a fusion machine or other item of equipment does not meet the requirements, the Owner/Consultant have the right to accept or reject the Machine and Contractor shall repair/replace such equipment without any cost implication to Owner.

6.2.2 Other auxiliary equipment

All other equipment used in producing the welds, such as current generators, re-rounding clamps, aligning clamps, scrapers, degreasing product etc. must be made available for inspection of Owner/Consultant & necessary clearance shall be obtained.

The degreasing products must be processed at site in their original packing unless express agreement has been obtained from the Owner/Consultant.

The Contractor must have sufficient tents or shelters available at the site of the work so that in unfavorable weather conditions the fusion can be continued under cover.

6.2.3 Preparation of the pipe

- Ovalisation on the external diameter must not exceed 2% for straight and 6% for coiled pipes. In case it is not meeting the criteria, same shall be brought to the notice of Owner/Consultant before welding/Jointing.
- 5 cm is sawn off from the pipe ends (flow).
- The effect of weather conditions must be minimized in order to ensure the fusion temperature and avoid moisture and dust in the fusion zone. Necessary protective covers like hood/temporary shades etc. shall be provided at the time of fusion by the Contractor.

Electrofusion can be made down to -10°C. Fusion shall only be performed outside these limits with the express agreement of the Owner/Consultant.

6.3 ELECTROFUSION

The inner wall of the electrofusion fittings is provided with an electric resistor. When a suitable energy source is applied, this resistor heats up the PE and softens the mass of both surfaces, resulting in a fusion pressure build up.

	EXECUTION OF WORK-	DOCUMENT NO.	Rev
	INSTALLATION OF	11-0269-02-07-02-006	0
	POLYETHYLENE PIPES	Page 12 of 24	

In order to ensure that this fusion pressure is built up, it is thus necessary to secure the smooth ends of the pipe and fitting properly with respect to the coupler.

6.3.1 Preparation procedure

6.3.1.1 Pipes and fittings with smooth fusion end(s)

- The pipes must be cut off cleanly and at 90⁰ angles; a PE pipe cutter or a hand saw is used for this purpose (in the case of the hand saw, the pipe is clamped in a pipe tensioner which also serves as a guide for the saw).
- The pipe end is deburred.
- Indicate the insert depth (half the coupler length).
- The pipe or fitting surface is treated as follows:
 - ☞ Cleaning of the pipe ends over a sufficient length;
 - ☞ Remove the oxidation layer with a suitable tool and/or scraper knife; a minimum of 0.15 mm material is removed, scraping must be done beyond the marking of the inserting depth;
 - ☞ Rebound the end of the pipe, using re-rounding clamps;
 - ☞ Clean the fusion surface using non-fluffing paper, soaked in a degreasing, volatile product; this product must be approved by the owner/consultant prior to the commencement of the works;
 - ☞ Leave to dry completely; if necessary, in cold weather, dry using a hot air generator;
 - ☞ Designate the insert depth again with marks;
 - ☞ In the case of saddles, scrape over a length greater than or equal to the width of the saddle +4 cm.

6.3.1.2 Electro fusion fittings

- Do not remove the fittings from their packaging until just before use.
- Carefully examine the:
 - ☞ internal condition of the wiring
 - ☞ cleanliness and condition of the connectors
 - ☞ Presence of bar code and magnetic card.
- Carefully examine and clean the internal surface of the fittings by using non-fluffing paper soaked in a degreasing, volatile product.
- Leave to dry completely, particularly between the resistor wires; if necessary dry using the hot air generator.

	EXECUTION OF WORK-	DOCUMENT NO.	Rev
	INSTALLATION OF	11-0269-02-07-02-006	0
	POLYETHYLENE PIPES	Page 13 of 24	

6.3.2. Electrofusion procedure

6.3.2.1 Insertion

Ensure while inserting that: -

- the insert depth is correct (to be checked using mark line).
- the terminals of the resistor are readily accessible.
- the resistor wire is not damaged.

The coupler is pushed by hand over the pipe or fitting, if necessary using a suitable tool or a rubber hammer.

If necessary, in the case of pipes on reels or coils, the pipe is hold straight with a suitable tool or a straight piece of pipe of 1 m is welded onto the pipe end, in order to avoid the curvature of the pipe at the site of the joint.

If several fillings have to be joined, these are first joined to each other the couplers are then welded.

To avoid exerting any forces on the fusion zone, the pipes are re-rounded and all the pieces to be welded are firmly clamped using a suitable tool throughout the welding cycle and until the electrofusion filling has cooled completely (minimum cooling time = 30 minutes). Particular inserting machines can be used as a damping tool. For the fusion of saddles, two round-pressing clamps are placed at ± 10 mm on either side of the saddle.

6.3.2.2 Fusion

The fusion cycle comprises at least the following phases:

- examination of the continuity of the electric circuit.
- examination of the regulation of the device.
- examination of the fusion time; it must be within the limits specified by the manufacturer of the electrofusion fitting.
- marking of the fused fitting to indicate that the fusion has been carried out.

If the fusion cycle is interrupted for one or other reason (for example a power failure, detachment of a terminal etc.), the same fitting may be fused a second time, on condition that the fusion cycle is only started after this fitting has cooled completely. Every such case must be reported directly to the Owner/Consultant with the location of the fusion concerned.

6.3.2.3 Checking of the electrofusion procedure

- Checking of the fusion method

- ☞ preparation of the pipes and fittings to be welded
- ☞ insertion
- ☞ clamping during fusion
- ☞ use of the fusion machine and follow-up of the fusion cycle

	EXECUTION OF WORK-	DOCUMENT NO.	Rev
	INSTALLATION OF	11-0269-02-07-02-006	0
	POLYETHYLENE PIPES	Page 14 of 24	

- Checking of the fusion

Each fusion is marked with the code of the welder and subjected to a visual examination (fusion indicators or ejected material).

The Owner/Consultant reserves the right to carry out a destructive test per site and per welder.

If the conditions in which the fusion was carried out cause doubt to arise on the good quality of the fusions, the Owner/Consultant can carry out destructive testing at any stage.

The following destructive tests shall be performed to ensure quality:

- Tensile tests:

The tensile test is carried out on a welded coupler, which is cut out of the pipeline; a pipe end with a minimum length of 0.5 m is cut out on either side of the coupler.

- Peel-off:

The peel-off test is carried out on a welded coupler which is cut out of the pipeline; a pipe end with a minimum length of 0.2 m is cut out on either side of the coupler.

The pipe and the coupler are cut through in the longitudinal direction in the workshop.

The pipe is pressed flat at either edge of the coupler, until the internal walls of the pipe come into contact with each other.

An attempt is made to wrench the coupler from the piece of pipe using a screwdriver or chisel. The parting line must not show a brittle break pattern.

The test described above can be replaced by the peel-off test described in the ISO standard [TC138ISC5/WGI2 N219], performed in a laboratory.

- Non-destructive tests:

The Owner/Consultant reserves the right to perform non-destructive testing on the fusions (ultrasonic or radiographic) at any stage of execution.

6.4. FOLLOW-UP OF THE FUSION INSPECTION

6.4.1. By the Contractor

- ☞ The Owner/Consultant reserves the right, at its expense, to search for defaults.
- ☞ The Contractor shall notify immediately the Owner/Consultant of any default of fusion.
- ☞ The defaults that have not been notified shall be considered as a breach of contract.
- ☞ The fusion joints concerned shall be located and replaced at the expense of the Contractor.

	EXECUTION OF WORK-	DOCUMENT NO.	Rev
	INSTALLATION OF POLYETHYLENE PIPES	11-0269-02-07-02-006	0
	Page 15 of 24		

6.4.2 By the Owner/Consultant

The Owner/Consultant has the right to have all fusions removed in case the fusion joints are rejected during inspection carried out by any of the one method defined as per Cl.6.3.2.3.

If an unacceptable fusion is attributed to a procedural error, the following has to be done without any cost implication to Owner:

- Two arbitrarily chosen fusions (by the same welder) are tested.
- If one of these two fusions is unacceptable, all the fusions (by the same welder) of the same day to be cut out and fully tested.
- If other two unacceptable welds are found, this welder shall not be allowed to do any more welding until he has received further training.

A pipe layer/fusion operator can be re-trained up to two times and workmanship still persists, then the operator shall be debarred from carrying out any further work at site.

6.5. REPAIR OF THE FUSIONS

All fusions declared to be unacceptable must be replaced, at the expense of the Contractor, by welding a new piece into the pipeline. This work shall be performed by a certified fusions operator and all the fusions joints shall go through the inspection procedure.

6.6. COST OF FUSION CHECKING AND REPAIRS

All the costs resulting from defects in fusion joints, supplementary checks and all repairs / replacements etc. shall be solely at the expense of the Contractor.

6.7. CHANGE IN DIRECTION OF THE PIPELINE

Changes in direction with a radius greater than 20 OD can be absorbed by the flexibility of the pipes. The changes of direction must never be absorbed in the fusions.

Changes in direction with a radius of less than 20 OD will be made with fittings intended for the purpose.

7. TESTS

7.1. GENERAL PROVISIONS

All materials and devices for performing the leakage tests shall be supplied by the Contractor. All fittings used in carrying out the tests must be suitable for a pressure which is at least equal to the test pressure and must be rigidly secured. In addition, the necessary action must be taken so that if a fitting nevertheless fails, the parts flying off do not cause injury.

	EXECUTION OF WORK-	DOCUMENT NO.	Rev
	INSTALLATION OF	11-0269-02-07-02-006	0
	POLYETHYLENE PIPES	Page 16 of 24	

A record has to be drawn up of these tests. This shall be signed by the Owner/Consultant and the Contractor.

Pipes shall not be tested at material temperature above 50 deg Centigrade.

7.1.1. A soundness test must be performed on the complete pipeline and a mechanical resistance test on MP pipelines.

7.1.2. Test medium shall be air or nitrogen for test pressure up-to 100psig. For test pressure higher than 100psig, water shall be used as test medium. Test duration shall be minimum 24 hrs. for plastic distribution mains of length greater than 1km and minimum 4 hours for length shorter than 1km. In case water is used as test medium, test duration shall start after achieving thermal stabilization. Suitable relieve valve set at 5% higher than test pressure shall be fitted at the test heads to avoid over pressurization during testing.

7.1.3. The couplings or pre-screwed joints of good quality; shall be used for tests in along with the following:

- A valve made for a pressure of 10 bar for LP and MP lines.
- A dial pressure gauge of the "Bourdon" type or equivalent, of accuracy class 1 and with the necessary scale range or a recording pressure gauge with the same accuracy. The scale divisions must be applied with at least one per tenth of a bar (nine gradations between each bar gradation). The pressure gauge is branched between the valve mentioned and the pipeline to be tested.

The Owner/Consultant has the right to check the pressure gauge(s) for accuracy at any time and to require immediate replacement of a defective or incorrect pressure gauge. Checking of the zero position of the pressure gauge is carried out by the Owner/Consultant before the pipeline is pressurized.

7.1.4. Before the pipeline is pressurized, it is examined again whether:

- All the fusion joints have cooled down sufficiently;
- All non-fusion joints and fittings are properly screwed on and are provided with the necessary seals;
- The pipeline is properly fixed, among other things by backfilling at the required places (in no event on the joints which must be tested) so that the pipelines do not undergo any dangerous displacements or changes of direction due to the internal pressure;
- Personnel have moved out of the vicinity of the trench.

During the test, only staff responsible for detecting any leaks may enter the trench close to the pipeline, but in no case behind the plugs.

	EXECUTION OF WORK-	DOCUMENT NO.	Rev
	INSTALLATION OF	11-0269-02-07-02-006	0
	POLYETHYLENE PIPES	Page 17 of 24	

7.1.5. All foam products should be halogen-free (non-corrosive, e.g. Trisilon) and approved by the Owner/Consultant.

7.1.6. The joints between the new pipeline and existing pipeline are to be tested by soap solution at service pressure.

7.2. EXECUTION OF THE TESTS

7.2.1. MP pipelines

DPRS and IPRS piping shall be subjected to strength test and leak test before commissioning as given in table below.

Test Requirements of DPRS and IPRS Piping			
Design Pressure	Min. Test Pressure	Test Medium	Min. Test Duration
Upto 138 mbarg (2 psig)	3.45 barg (50 psig)	Air	2 hours
From 138 mbarg to 4.14 barg (2 to 60 psig)	1.5 times Design Pressure	Air	2 hours
Above 4.14 barg (60 psig)	1.5 times Design Pressure	Water	2 hours

Acceptance criteria shall be no pressure loss after accounting for temperature variation.

Before being put into service, the polyethylene pipelines are subjected to:

- 1. A mechanical resistance and soundness test.
- 2. The PE pipelines are subjected to a test pressure of 7.5 bar for MD for at least 6 hours from the time when this pressure is reached and has been stabilized.
- 3. The pressure gauge must measure an unchanged pressure during the tightness test.
- 4. All pressures for MP tests must be recorded and the diagrams handed over to the Owner/Consultant after the test.
- 5. In the event of doubt over whether an unchanged pressure is maintained, the Owner/Consultant can have an additional tightness test performed at 50 mbar with a water manometer.
- 6. For venting and any repair required, see 7.2.2.

	EXECUTION OF WORK- INSTALLATION OF POLYETHYLENE PIPES	DOCUMENT NO.	Rev
		11-0269-02-07-02-006	0
	Page 18 of 24		

7.2.2. LP pipelines

Before they are commissioned, the polyethylene pipelines are subjected to a pressure of 1 bar for at least 1 hour, counting from the time at which this pressure is reached after stabilization.

The following techniques are possible for checking tightness:

- If possible, all joints are carefully checked with a suitable foaming agent one by one over their whole circumference for bubble formation.

Each joint must be accessible and visible all round and over a sufficient space. The joints which are in the trench must be properly dug free all round.

Wherever possible, a clear-image mirror with a sufficient surface area must be used in order to discover even the smallest bubble formation with certainty underneath the joints.

- In other cases, the tightness is checked as a function of the volume of the installation by suitable techniques approved by the Owner/Consultant.

A chart record is required.

The pressure gauge must measure an unchanged pressure during the tightness test. In case of doubt, the delegate of the Owner/Consultant may require a recording pressure gauge or have an additional tightness test carried out at 50 mbar with a water manometer (see 7.2.3.).

After all the joints have been checked, the compressed air is vented. Suitable precautions must be taken for this purpose to prevent the air escaping when venting takes place from causing soil, stones or other objects to fly. In addition, all bystanders shall move at a safe distance from the pipeline and the trench.

If the laid pipeline is shorter than 100 m and all the joints and welds can be examined with a suitable foaming agent for bubble formation, the above test can be replaced by a tightness test at gas distribution pressure.

The leaks found at mechanical joints are immediately repaired, while leaking fusion joints are expertly replaced.

The tightness test is afterwards repeated as stipulated above.

7.2.3. Tightness test at 50 mbar with water manometer or pressure gauge recorder

The test may only start after the temperature and the pressure in the pipeline have stabilized and lasts at

	EXECUTION OF WORK-	DOCUMENT NO.	Rev
	INSTALLATION OF	11-0269-02-07-02-006	0
	POLYETHYLENE PIPES	Page 19 of 24	

least one hour. Any variation in pressure which does not stabilize is reported to the Owner/Consultant for assessment.

If a repair is required, the tightness test is repeated according to all the above stipulations, the repaired joints being checked again.

Testing of the pipelines - Summary

	LP	MP
1.Mechanical Resistance(1)	AIR OR inert gas	AIR OR inert gas
2.Soundness(2)		7.5 barg (6 hours)
-Foaming Product	1 bar(1 h)	
-Manometer-mains	1 bar(1 h)	
-services	1 bar(1 h)	
If L<100 m, foaming product	Distribution pressure	
-Water manometer at 50 mbar(3)	1 hour	1 hour
3.Non-destructive Test		
-visual	100%	100%
- US or Radiographic	Random sampling	Random sampling
(4. Destructive	Random sampling	Random sampling

1) For service pipelines, the test duration may be reduced to 1 hour;

(2) Checking by soaping or using pressure gauge, depending on the case;

(3) this test may be optionally stipulated.

Remarks:

- if no single test duration is mentioned, the pressure is maintained for the time necessary for soaping;
- the times indicated are minimum values.

	EXECUTION OF WORK-	DOCUMENT NO.	Rev
	INSTALLATION OF	11-0269-02-07-02-006	0
	POLYETHYLENE PIPES	Page 20 of 24	

8. NON-FUSION JOINTS

Flanged joints or other non-fusion joints are not permitted.

9. CATHODIC PROTECTION

If during work on the polyethylene pipelines steel gas pipes are locally used or if any change occurs in the Cathodic protection of existing steel gas pipes, the special specifications for steel pipes can be consulted in the section headed "Preparation of the grid in connection with the use of cathodic protection".

10. SPECIAL WORKS

10.1. TRENCHLESS CROSSINGS

The following must be carried out strictly and without exception:

- 1) The internal diameter of the sleeve must be at least 100 mm greater than that of the pipeline (for pipelines up to diameter 200 mm).
- 2) Insulating support collars supplied by the Owner/Consultant are fitted on the section of pipeline placed in the sleeve. The maximum distance between support collars is 2.5 m. The first and last support collars are fitted no more than 0.5 m from the ends of the sleeve.
- 3) The extremities of the sleeve are sealed against the pipeline by specially designed rubber bushes which are connected by clamping brackets around the pipeline and the sleeve.
- 4) The sleeves for jacking are fibre-cement pipes or steel pipes.
- 5) In a road where electricity cables are present and where it is necessary to drill through, the cables lying in the path of the drilling must be completely exposed before starting to drill.

10.2. PROTECTION WITH SLEEVES

At those places where the buried pipeline requires special protection, it is also possible to use sleeves. The Owner/Consultant stipulates when and which sleeve is used.

	EXECUTION OF WORK-	DOCUMENT NO.	Rev
	INSTALLATION OF	11-0269-02-07-02-006	0
	POLYETHYLENE PIPES	Page 21 of 24	

10.3. COUPLING OF NEW PIPELINES TO EXISTING ONES

The practical instructions for installing the new pipeline at the coupling to the existing network are laid down on the spot. The Contractor will contact the Owner/Consultant for this purpose at the appropriate time.

The coupling to the existing network is generally carried out by the Owner/Consultant. However, this work can also be allocated to the Contractor who carries it out under the instructions and supervision of the Owner/Consultant.

Unless otherwise agreed with the Owner/Consultant, this coupling takes place immediately after the tests have been completed.

The earthworks and repaving works are to be carried out by the Contractor.

10.4. INSTALLATION OF VALVES

The installation of valves comprises:

- 1) The necessary trench adjustments where the valve is installed;
- 2) The installation of a stabilized footing (100 kg cement to 1 m³ sand) with a thickness of 10 cm for the support of the valve;
- 3) The welding or connection of the valve in the pipeline;
- 4) The insulating coating of metallic parts in the worked zone;
- 5) The isolation of the spindle at the correct length and the installation of the protective pipe;
- 6) The installation at the correct desired height, above each valve, of the hatch and cover made available by the Owner/Consultant, on a concrete footing.

10.5. INSTALLATION OF PURGING LINES

Purging lines are installed at the places designated by the Owner/Consultant, such as:

- before and after each valve;
- at the end of the pipelines.

- 1) The necessary trench adjustments at the site of the purging line;
- 2) The construction of the purging line according to the Owner/Consultant's plan with materials made available by the Owner/Consultant;
- 3) The isolating coating of the purging line where appropriate according to the Owner/Consultant's instructions;
- 4) The installation at the desired height of the hatch and cover made available by the Owner/Consultant, on a concrete footing.

10.6. CLEANING OF THE PIPELINE

	EXECUTION OF WORK-	DOCUMENT NO.	Rev
	INSTALLATION OF	11-0269-02-07-02-006	0
	POLYETHYLENE PIPES	Page 22 of 24	

After testing, it may be required that a brush or a plug (scraper) is pushed through the pipeline. This is done until all foreign objects have been removed from the pipeline.

If water has also entered during cleaning, it is rinsed where appropriate with methanol, provided agreement has been obtained from the Owner/Consultant.

10.7 SPECIFIC SAFETY MEASURES

10.7.1 General

Always check that THERE IS NO FIRE OR SOURCE OF HEAT in the immediate vicinity of the excavation (smoking, welding equipment, generator sets, halogen lamps, wall radiators etc.). Make sure that you can always leave the excavation quickly and easily.

Install the FIRE EXTINGUISHER IN THE IMMEDIATE VICINITY of the excavation.

10.7.2. Static electricity

Gas might escape in certain works. This outflow of gas can generate static electricity on the PE pipeline. Any contact of the pipe or fittings can cause discharge, with the striking of an arc. This arc can cause the gas to ignite.

That is why it is necessary to take always the following safety measures:

- Moisten the PE pipeline and surroundings.
- Earth the PE pipeline beforehand by winding a wet cotton strip in a spiral around the pipeline.

Connect the cotton strip to earth throughout the duration of the work in which gas is released.

This is done to avoid discharges of static electricity causing fire in the trench.

10.7.3. Outflow of gas

While work is being carried out at gas pressure, LIMIT ANY ESCAPES OF GAS TO AN ABSOLUTE MINIMUM.

10.7.4. Gas bags

The use of GAS BAGS is subject to the following rules:

- Always wear your SAFETY GLOVES AND SAFETY GOGGLES during installation;
- Keep a gas bag UNDER CONSTANT SUPERVISION;
- LIMIT THE TIME BEFORE USE TO A MINIMUM, in other words first complete all preparatory work;
- When working over a prolonged period, alongside the use of a gas bag, TAKE ADDITIONAL MEASURES to ensure the shutting-off of gas (e.g. installing a plug).

The work must also remain under supervision in all cases.

	EXECUTION OF WORK- INSTALLATION OF POLYETHYLENE PIPES	DOCUMENT NO.	Rev
		11-0269-02-07-02-006	0
		Page 23 of 24	

ANNEXURE - 1

d mm	e mm	SDR	Length m	Weight kg/m
20	3.0	11	200 mtr. in reels	0.162
32	3.0	11	200 mtr. in reels	0.28
63	5.8	11	100 mtr. in reels	1.05
125	7.4	17.0	50 mtr. in reels	3.5

	EXECUTION OF WORK- INSTALLATION OF POLYETHYLENE PIPES	DOCUMENT NO.	Rev
		11-0269-02-07-02-006	0
		Page 24 of 24	

**AAVANTIKA GAS LIMITED
CITY GAS DISTRIBUTION PROJECT**



PTS FOR PE PIPELINE – CONSTRUCTION

CLIENT JOB NO.

-

TOTAL SHEETS

10

DOCUMENT NO

11

0269

02

07

02

031

--	--	--	--	--	--

0	18.10.09	ISSUED FOR CLIENT COMMENTS	AP	SB	SB
A	16.10.09	ISSUED FOR IDC	AP	SB	SB
REV	DATE	DESCRIPTION	PREP	CHK	APPR

PTS FOR PE PIPELINE – CONSTRUCTION

	PTS FOR PE PIPELINE –	DOCUMENT NO.	Rev
	CONSTRUCTION	11-0269-02-07-02-031	0
	Page 2 of 10		

TABLE OF CONTENT

1.0 INTRODUCTION.....4

2.0 TECHNICAL REQUIREMENTS: PE LAYING4

3.0 TEMPORARY SEALING OF PIPE ENDS9

4.0 WELDING AND FUSION WORKS9

5.0 CHANGE IN DIRECTION 10

	PTS FOR PE PIPELINE –	DOCUMENT NO.	Rev
	CONSTRUCTION	11-0269-02-07-02-031	0
	Page 3 of 10		

PTS FOR PE PIPELINE – CONSTRUCTION FOR MAINLINE AND SERVICE LINE

1.0 INTRODUCTION

- 1.1 PTS shall be read in conjunction with the General and Special Conditions of Contract, General Technical Specifications (GTS) of work, drawings, SOR and other document forming part of the contract wherever the context so requires.
- 1.2 Where any portion of the General Technical Specifications is repugnant or variance with any provisions of the particular technical specifications, unless a different intention appears, the provision (s) of particular technical specification shall be deemed to govern the provision(s) of General Technical Specifications of contract. If there is no variance or repugnance between General Technical and Particular Technical Specifications both clauses shall be applicable.

2.0 TECHNICAL REQUIREMENTS: PE LAYING

- 2.1 The scope of work and technical requirements associated with PE pipe laying in different types of earth surfaces are as follows.

Type A

Pipe laying in unmade surface of any type, i.e. grassed areas, rough ground, etc. includes for the reinstatement of the surface to existing and safe conditions. This also includes for replanting of plants, shrubs, trees and turf that may have been removed during excavation. This will also apply where pipes are laid in ducts, which have been installed by others.

Type B

Pipe laying in a made-up surface. It includes taking up of a hard surface of any type i.e. metal, asphalt/tarmac, concrete etc. The Contractor is required to backfill and carry out a temporary reinstatement, in accordance with Clause 2.3 below & Drawing No. STD-19-152, Rev.0.

- 2.2 a) Trenching, back filling and reinstatement work required to meet Owner’s / authorities having jurisdiction specifications and requirements. Where the permanent surface reinstatement is not to be completed immediately, the Contractor will provide and maintain a suitable temporary running surface for vehicular traffic and pedestrians. The Contractor will be responsible for the maintenance of all reinstatement carried out, according to the requirements in each surface category, for the duration of the contract guarantee period.

b) PE laying across the C.C. Roads shall be crossed through HDPE casing.

- 2.3 The back filling and restoration of trenches will be carried out in accordance with OWNER’s REINSTATEMENT SPECIFICATION which is attached as Drawing No. STD-19-152, Rev.0 and explained below. OWNER reserves the right to make modifications to this specification where special circumstances dictate. The Contractor will ensure that reinstatement is carried out under the supervision of certified personnel. Reinstatement will also be inspected by OWNER / Owner’s representative as it is carried out and on completion, particularly with respect to material suitability, layer thickness and the degree of compaction achieved. Where the required standards are not achieved, the Contractor will be required to replace the defective reinstatement, including re-excavating of the trench as necessary.

Drawing No. STD-19-152, Rev.0: TYPICAL TRENCH /REINSTATEMENT DETAILS.

a. Where a temporary surface reinstatement is required, the materials to be used in each layer shall be as follows:

	PTS FOR PE PIPELINE –	DOCUMENT NO.	Rev
	CONSTRUCTION	11-0269-02-07-02-031	0
Page 4 of 10			

Fine fill: Suitable excavated material of grit size less than 5 mm. A riddle may be used to produce a fine material. Where necessary a suitable material shall be brought in from other places.

Backfill: suitable excavated material.

Road-base/sub-base: as directed by the Owner/Owner's Representative, taking into account the particular arrangements for final surface reinstatement. This will normally be material, brought in from other places, of aggregate sizes 40 mm to dust and well graded.

b. Where a permanent surface reinstatement is required, the materials to be used in each layer shall be as follows:

Fine fill: suitable excavated material of grit size less than 5 mm. A riddle may be used to produce a fine material. Where necessary a suitable material shall be brought in from other places.

Backfill: suitable excavated material.

Road-base / Sub-base: suitable excavated material, with aggregate sizes 40 mm to dust, and well graded. Where necessary a suitable material shall be brought in from other places.

Running surface: bituminous or concrete material, as directed by the Owner/Owner's Representative, considering the particular arrangements for final surface reinstatement, and the requirements of the road authority. Permanent reinstatement of asphalt portion should match with the original condition or as directed by the OWNER.

c. Fine fill material shall be carefully packed around the pipe and attached fittings, and firmly rammed with a hand tamper.

d. Backfill, sub-base and road-base materials shall be placed in layers of a maximum un-compacted thickness of 100 mm and compacted, using 4 passes of a suitable hand rammer, pneumatic rammer, or preferably a mechanical vibro-tamper.

Each layer of material will be watered in as it is laid to ensure that an optimum moisture content is maintained, and as per the instructions of the Engineer – in - charge.

The running surface material will be laid and compacted using a mechanical vibro-tamper or roller.

e. Concrete Surfaces

The general principle will be to reinstate concrete surfaces to a standard comparable with the existing footpath/roadway. However, to prevent cracking the minimum layer thickness for roadway/driveways the minimum thickness will be 150 mm.

The fine fill, backfill and sub-base materials will be laid and compacted as per the general requirements, as detailed in Sections a & b. These layers will be laid such that the level of the sub-base will match the depth of concrete required.

The concrete mix to be used shall be 1:2:4 or to match the existing roadway as directed by OWNER.

The finished surface will be matched to that of the existing as closely as possible. Crowning of the reinstatement will not be permitted.

To retard curing of the laid material wet sacking or other suitable material will be laid on the finished surface and kept in a wet condition for a minimum of 36 hours.

f. Slabbed and Block Surfaces

The existing slabs or blocks will be lifted with care to avoid damage and stacked for re-use. The Contractor will be responsible for site security and will replace any lost or damaged tiles at his own cost,

	PTS FOR PE PIPELINE –	DOCUMENT NO.	Rev
	CONSTRUCTION	11-0269-02-07-02-031	0
	Page 5 of 10		

except where tiles are unavoidably damaged during lifting and this is agreed by the Owner/Owner's Representative.

Backfill and sub-base materials will be laid and compacted as per the general requirements, as detailed in Section a & b. These layers will be laid such that the level of the sub-base will match the depth of bedding required and the slab/block thickness.

The slabs or blocks should be laid on moist bedding material, which should be graded sand, mortar or a mortar mix. The bedding material shall be spread over the whole area of the sub-base to match the existing thickness, or to a minimum of 25 mm.

The slabs or blocks should be tapped into position to ensure that they do not rock after laying. The reinstated slabs or blocks should match the surrounding surface levels and adjacent slabs with ± 6 mm throughout.

The joints between the slabs or blocks will be filled with a dry or wet mix to match existing. Joint widths should be laid to match the existing surface.

- 2.4 Trench work claims will only be authorized on satisfactory completion of the reinstatement appropriate to the work type, and when the site has been cleared of all spoil, surplus materials etc, and has been accepted by the OWNER.
- 2.5 Trench work will be carried out to the dimensions specified at **clause 2.20**, except where otherwise directed by the OWNER to enable jointing, or the negotiation of obstructions, etc. Where trenches are made wider than the specifications without the agreement of the OWNER, then the Contractor will be liable for any excess reinstatement charges levied on OWNER by the authorities.
- 2.6 (a) In certain situations, depending upon underground utilities/ structure, it may be necessary to install pipes at depths greater than the minimum cover of 1.0 mtrs. However, the rates shall be same as applicable to cover 1.0 mtrs.
- b) In case however where the pipeline is permitted to be laid with top cover less than 1000 mm but greater than 600 mm due to site constraint to be specifically agreed by OWNER in writing and duly approved by Third Party Inspection Agency, if applicable, the additional protection like G.I. sleeve, Hume pipe, supplied by contractor, should be installed at no extra cost to the OWNER. Shoring or trench supports to be provided in deep excavations, or in unstable ground conditions, if required.
- 2.7 Before lowering the pipe, sand padding of 75 mm will be done at the trench bottom, similarly, after the lowering, the trench will have to be filled with sand around and up to 75 mm from the top of pipe and soft graded soil layer of 125 mm above layer of sand. Subject to approval of Client/Consultant site Engineer / TPIA, contractor may use excavated earth or brought in soft graded soil from other places. The soil to be filled up should be stone free properly graded having max. grit size of 5 mm, non-bio organic & non-corrosive. Contractor has to do padding with sand/Anti-Rodent Tape in case of open cut, HDPE Duct/ Anti-Rodent Tape in case of moulting where GC is done inside house premises/multi store buildings.
- 2.8 Any hard rock strata which is encountered during excavation and if same cannot be removed other than use of pneumatic chisel/ drilling or using sledge hammer and chisel and of single piece dimension exceeding 1.5 mtr. length shall be considered as hard rock. The rate quoted for PE laying shall be inclusive of above job scope also. However, payment for excavation of hard rock shall be separate and as per SOR.
- 2.9 Installation of valves (supplied by OWNER) on PE line at locations considered appropriate by OWNER. The valve shall be supported on a bed of firmly compacted fine fill of grit size not greater than 5 mm, to sleeves to be supplied by OWNER. The valve pit will be constructed including supply of all material as per the drawing at Drawing No.STD-19-142 Rev.1 & 2.

	PTS FOR PE PIPELINE –	DOCUMENT NO.	Rev
	CONSTRUCTION	11-0269-02-07-02-031	0
Page 6 of 10			

- 2.10 Jointing of pipes shall be as per General Technical Specification. Jointing will be carried out by electro fusion method only. Supply of necessary fusion equipment is in scope of contractor. In general, pipes will be supplied as follows:

<u>Nominal Dia.</u>	<u>Lengths</u>
20 mm	200 mtrs. in reels
32 mm	200 mtrs. in reels
63mm	100 mtrs. in reels
125mm	50 mtrs. in reels

The testing, purging and commissioning of pipeline network has to be done to OWNER's requirements. Pressure testing will be carried out either with compressed air or nitrogen, and no other test medium will be used. Compressed air or nitrogen cylinders will be provided by the Contractor. Nitrogen will be supplied in labeled, tested and certified cylinders, and complete with all necessary regulators, hoses and connections, which will be in good order and working condition. No extra payment will be made for any delays incurred, or repair or rectification work found necessary as a result of test failures, where this is the result of faulty workmanship or negligence on the part of the Contractor.

- 2.12 Provision of the safe signing, barricading shall be as per at Drawing No.STD-19-146 & 147, Rev.0. and night lighting at all excavations and works. Failure to comply with this to the satisfaction of OWNER will result in work either being suspended or closed down until appropriate arrangement for protecting excavations is made available. The Contractor shall inspect all fenced off excavation daily, and maintain them in good order as necessary.
- 2.13 The contractor shall ensure removal and disposal of all waste materials and packaging, including spare pipe and pipe off cuts. These shall be returned to the OWNER store and reconciled against the pipe issued.
- 2.14 The contractor shall also ensure laying of PE warning tape, to be provided by contractor, approx. 400 mm above the buried pipe. Where the required pipe covers cannot be achieved, or in special circumstances, other barrier protection methods may be approved and specified by the Client/Consultant site Engineer / TPIA e.g. Protection with concrete pipes/ G.I. pipes etc. The PE laying rates shall also include supply/transportation/fitting of these protections. The warning tape shall be made of Polyvinyl Chloride or Polyethylene and shall be of bright Golden Yellow Colour. The width of the tape shall be 300mm+5 mm and thickness of 1 mm. The marking on the film shall be approved by the Owner.
- 2.15 The contractor shall supply and arrange all necessary pumping equipment and power sources to dewater trenches and excavations as required by OWNER. No extra payment will be made by the OWNER on this head.
- 2.16 The contractor shall make adequate trial holes necessary to determine the pipe route and locate other underground utilities, plant or investigate possible obstructions. The Contractor will obtain all available information regarding the existence and location of other underground utilities, plant and possible obstructions, and the number and location of trial holes to be taken out will be agreed with the Client/Consultant site Engineer / TPIA in advance, however, at least at 30m intervals contractor shall make trial pit. Trial holes will be excavated to a depth of pipe depth +250mm, and will be reinstated in accordance with OWNER's reinstatement specification. Where trial holes are not backfilled immediately they will be protected and fenced in accordance with the requirements provided by the OWNER. There will be no additional payments in respect of abandoned trenches and expenses incurred because of insufficient or inadequate trial holes, or any associated lost time or delays.
- All drains/ culverts/ nallahs should be crossed at least 1000 mm below the bed level & PE pipe to be laid through HDPE Casing.
- 2.18 a) For all PE pipes except 20mm service pipe will be laid with a minimum clearance of 300 mm from other underground services, unless otherwise agreed with the Client/Consultant site Engineer /TPIA. Where

	PTS FOR PE PIPELINE –	DOCUMENT NO.	Rev
	CONSTRUCTION	11-0269-02-07-02-031	0
	Page 7 of 10		

this minimum clearance cannot be achieved, then it is necessary to install some suitable barrier protection between the pipe and the services(s) like RCC slab/ PVC sheet supplied by contractor & the fitting/ transportation of this to site shall be included in the rates.

In case of 20 mm service pipe minimum clearance of 300 mm from other underground services if parallel to the utility and 150 mm if crossing the utility to be maintained unless otherwise agreed with the Client/Consultant site Engineer / TPIA. Where this minimum clearance cannot be achieved, then it is necessary to install some suitable barrier protection between the pipe and the services(s) like RCC slab/ PVC sheet supplied by contractor & the fitting/ transportation of this to site shall be included in the rates.

Pipe route to be finalized with avoid of parallel to Electrical cable, but whether it is not possible minimum clearance from electric cables for all PE lines shall be maintained 500 mm unless otherwise agreed with the Client/Consultant site Engineer / TPIA. Where this minimum clearance cannot be achieved as agreed by Client/Consultant site Engineer / TPIA, then it is necessary to install suitable barrier protection between the pipe and the services(s) like RCC slab/ PVC sheet/ Brick Protection supplied by contractor & the fitting/ transportation of this to site shall be included in the rates.

- b) Trench should be kept min. 1 mtr. away from CC road edge. If it is not possible to adhere to the requirements above, then barricading should be so arranged that traffic load (vehicle wheel) remains min. 1 mtr away from the nearer face of the trench during the construction phase. If the trench is within 0.5 mtr of the edge of CC road, unless otherwise agreed with the Client/Consultant site Engineer / TPIA, full shoring and strutting need to be provided during construction phase and 1.5 mm thick. HDPE sheet, supplied by contractor, along vertical face of the trench nearer to CC roadside should be provided before back filling the trench as shown at Drawing No.STD-19-149, Rev.0.
- 2.19 PE pipe may be laid by moiling technique by prior approval of Client/Consultant site Engineer. Provision of moling equipment is in the scope of contractor. For machine moling Contractor will supply a 60cm mobile air compressor or equivalent (with hose and connections) to power the moling equipment.
- 2.19.1 For moled and inserted pipe, the edge to edge length of the mole will considered as moling length and those sections laid by open cut in launch, receipt and connection excavations will considered as open cut. No additional payments will be made for any delays incurred as a result of the intermediate excavation, variability of moling speeds, blockages in ducts or for any other reason.
- 2.20 The following table specifies the maximum trench widths and minimum depths of cover for the various sizes of PE pipes to be laid. Any deviation from the trench widths specified will not alter the linear rates of PE laying.

PIPE SIZE (DIA)	MAXIMUM TRENCH WIDTH	MINIMUM COVER
20, 32, 63,125,180 mm	450 mm	1000mm

- 2.21 The contractor will be required to submit the computerized as laid drawings for PE Pipe network duly certified by Client/Consultant site Engineer & concurred by Third Party Inspecting Agency appointed by OWNER in A3 / A2 / A1 / AO sheet (as suitable) on one set of tracing polyester film at 1:500 scale along with five sets of blue prints for the work carried out. The As- Laid drawing should include sufficient details for locating laid pipe line with respect to permanent structures/ markers, recording length and depth of pipe work laid including surrounding utilities details.
- 2.22 Contractor shall take utmost care to avoid damages to underground utilities. Additional protection shall take for utilities pipe, cable, etc. on main roads. In case any such incident occurred, it has to be rectified to the satisfaction of concerned authority of utility damaged, immediately by contractor within quoted rates, failing which OWNER will get it done at risk & cost to the contractor and suitable penalty shall be applicable.
- 2.23 WORK PERMITS & PERMISSIONS

	PTS FOR PE PIPELINE –	DOCUMENT NO.	Rev
	CONSTRUCTION	11-0269-02-07-02-031	0
Page 8 of 10			

The scope of work and other requirements associated with the work permits and permissions are as follows and shall be covered under PE laying rates.

- a. Basic permission for laying of underground pipeline from concerned authorities is in contractor scope. Contractor shall be responsible for obtaining further specific approval from statutory authorities like Municipal Corporation, PWD, Fire Department and any other concerned authority as required for the completion of the work.
- b. The prospective bidder shall work in close consultation/ co-ordination with the Site Engineer and keep fully apprised and informed about the various paper/documents, applications being filed with the authorities / utilities as above. A copy of all the documents/ applications including enclosures duly acknowledged by the authorities/ utilities shall be forwarded to the Client/Consultant site Engineer within three days from the date of acknowledgement by the respective authorities / utilities.
- c. The prospective bidder shall not sign / execute any agreement and/or undertaking of any such documents which amounts to be undertaken by OWNER and which shall only be signed and executed by OWNER. However, the prospective bidder shall also ordinate for the same.
- d. The necessary co-ordination, liaison and arrangements for statutory inspection and approval shall be the contractor's responsibility, inspection and acceptance of the work by statutory authority shall not relieve the contractor from any of these responsibilities under this contract.
- e. Any change/ additions required to be made to meet the requirements of statutory authorities, shall be carried out by the contractor, within the contract price and to no additional cost to owner.

2.24 Due to site constraints if it is not possible to adhere to OWNER drawings / specifications /OWNER code of practice, in such cases contractor shall request for technical deviation and same to be approved by Client/Consultant site Engineer / TPIA before carrying out further work.

2.25 Contractor shall submit the documents, which include but not limited to the following:

- a. As laid drawing
- b. Third Party Inspection Report
- c. Approval of technical deviation, if any.
- d. Material Reconciliation Report.
- e. NOC certificate from concerned authority for reinstatement.
- f. Material Test certificate.

The above job scope mentioned shall be covered under the rate quoted for PE laying.

3.0 TEMPORARY SEALING OF PIPE ENDS

- 3.1 Any pipe which is temporarily left alongside the trench shall always be protected against water ingress and the introduction of impurities by means of a plug or a cap. Particular attention shall be paid to these plugs while the pipe is laid in the trench. The plugs or caps shall be designed in such a way that they can be easily removed without disappearing into the pipe. The contractor shall ensure that he has enough plugs or caps for the various different diameters of pipes to be laid.
- 3.2 The ends of pipes temporarily left behind in the trench shall be sealed so as to prevent water or mud to penetrate even if the trench is completely filled with water. To do this, appropriate plugs or caps may be used.
- 3.3 The presence of water or impurities in the pipe shall be considered as a serious fault by the contractor. In this case, the OWNER/ Consultant will oblige the contractor to clean the pipeline, at his own expenses, using a pipe cleaner, until the water, dirt or any other impurity has been removed.

4.0 WELDING AND FUSION WORKS

	PTS FOR PE PIPELINE –	DOCUMENT NO.	Rev
	CONSTRUCTION	11-0269-02-07-02-031	0
Page 9 of 10			

4.1. The welder or fusion operator must be in possession of a certificate, issued by the OWNER/ Consultant , confirming that he has satisfied the above conditions. As the permit has an expiry date, the welder or the fusion operator shall be required to renew it before that date.

This permit shall not relieve the contractor of his responsibility in the event of an inadequate work, accident or damage occurring during the course of the works for which he is appointed.

Each qualified welder or fusion operator shall be in the possession of identification markers, with which he identifies the weld carried out by him on the pipe.

4.2. Execution of welded joints

The welds shall be formed in accordance with procedures approved by the OWNER/ Consultant and, unless otherwise specified, in compliance with the requirements: General Technical specification 11- 0269-02-07-02-006.

Electro fusion shall be the only acceptable process for PE pipe.

The electro fusion equipment used shall meet the requirements of the relevant specification.

The electro fusion works shall also be monitored, as described in the relevant Specification.

5.0 CHANGE IN DIRECTION

Changes in direction after which the radius of curvature remains greater than 15D may be formed using the flexibility of the material. However, they shall not be located where there are welds or fittings.

Changes in direction that give a length of pipe work a radius of curvature of less than 15D shall be formed using the appropriate fittings (elbows or bend of 45° and 90°).

	PTS FOR PE PIPELINE –	DOCUMENT NO.	Rev
	CONSTRUCTION	11-0269-02-07-02-031	0
	Page 10 of 10		

**AAVANTIKA GAS LIMITED
CITY GAS DISTRIBUTION PROJECT**

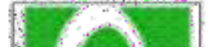

TECHNICAL SPECIFICATION FOR HDPE					CLIENT JOB NO.		
					TOTAL SHEETS		04
DOCUMENT NO	11	0269	02	07	02	032	

--	--	--	--	--	--	--

0	18.10.09	ISSUED FOR CLIENT COMMENTS	AP	SB	SB
A	16.10.09	ISSUED FOR IDC	AP	SB	SB
REV	DATE	DESCRIPTION	PREP	CHK	APPR

TECHNICAL SPECIFICATION FOR HDPE

	PTS FOR PE PIPELINE –	DOCUMENT NO.	Rev
	CONSTRUCTION	11-0269-02-07-02-032	0
	Page 2 of 4		

TABLE OF CONTENT

1.0 Intent of Specification4
2.0 Scope of work4
3.0 Instruction to Tenderer.....4

	PTS FOR PE PIPELINE –	DOCUMENT NO.	Rev
	CONSTRUCTION	11-0269-02-07-02-032	0
	Page 3 of 4		

TECHNICAL SPECIFICATION FOR HDPE

1.0 Intent of Specification

The intent of this specification is to establish minimum requirements to manufacture and supply of HDPE pipes used for casing purpose of carrier pipe, supplying natural gas.

2.0 Scope of work

2.1 The scope of the tenderer will include manufacture / supply, inspection / testing / marking / packaging / handling and dispatch of HDPE pipes of ratings and grades as indicated in the Material Requisition and Schedule of Rates as per IS: 4984 (Specification of HDPE pipes for water supply).

2.2 All codes and standards for manufacture, testing, inspection, etc. shall be of latest edition.

2.3 Purchaser reserves the right to delete or order additional quantities during execution of order, based on unit rates and other terms and conditions in the original order.

3.0 Instruction to Tenderer

3.1 Length of the pipes and their supply will be as per following:

<u>Nominal Dia (Di)</u>	<u>Thickness</u>	<u>Material</u>
90mm	SDR21	PE100 Polyethylene
160mm	SDR21	PE100 Polyethylene
250mm	SDR21	PE100 Polyethylene

3.2 Protection

- i. The ends shall be protected by proper end caps to prevent from shocks and ingress of the foreign body.
- ii. Coils shall be covered by black PVC / PE film to prevent exposure to direct sun light.

3.2.1 The successful bidder shall submit following for approval of Purchaser / Consultant after placement of order.

- a. The Quality Assurance Plan (QAP & Sampling Plan)
- b. Material test report as per clause 5 of IS: 4984
- c. Performance Requirements (Clause 8 of IS:4984)
- d. Type test (Clause 9.1 of IS: 4984)

3.3 The bidder shall submit following documents at the time of bidding.

- a. BIS Certification.
- b. List of current orders in hand for similar items with full details such as specification, name or purchase etc.
- c. Details of the largest supply executed.
- d. Name and address of proposed test laboratories along with their credentials / past records for carrying out all required tests.

	PTS FOR PE PIPELINE –	DOCUMENT NO.	Rev
	CONSTRUCTION	11-0269-02-07-02-032	0
	Page 4 of 4		

**AAVANTIKA GAS LIMITED
CITY GAS DISTRIBUTION PROJECT**

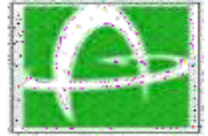

TOOLS AND EQUIPMENT TO BE PROVIDED BY THE CONTRACTOR PE LAYING	CLIENT JOB NO.	-
	TOTAL SHEETS	02

DOCUMENT NO	11	0269	02	07	02	047
--------------------	----	------	----	----	----	-----

--	--	--	--	--	--

0	18.10.09	ISSUED FOR CLIENT COMMENTS	AP	SB	SB
A	16.10.09	ISSUED FOR IDC	AP	SB	SB
REV	DATE	DESCRIPTION	PREP	CHK	APPR

ANNEXURE: I

Tools and Equipment to be provided by the contractor for PE Laying

- 1.0 Electrofusion generator and control box with leads.
- 2.0 Moling Equipment, HDD Equipment.
- 3.0 MDPE Squeeze tools for 180,125, 63, 32, and 20 mm pipes.
- 4.0 Universal pipe scraper 20mm – 125 mm / hand scrappers.
- 5.0 Tapping tools for PE Service tees.
- 6.0 PE pipe cutter / Guillotine.
- 7.0 Gas detection equipment, wherever required.
- 8.0 Cable and pipe locator.
- 9.0 PE closure plugs / test ends for 180,125, 63, 32, and 20 mm pipes.
- 10.0 Towing heads.
- 11.0 Pipe alignment clamps, clamps for alignment, jointing of elbow, tee, top loading clamps for top tee.
- 12.0 Pipe straightners, re-rounding tools of all pipe sizes.
- 13.0 Jumping Jack compactor.
- 14.0 Roller for asphaltting.
- 15.0 Water tanker.
- 16.0 Any other equipment / tool required for completion of job.
- 17.0 Oxygen Detector for confined space work and during commissioning of MDPE pipeline.
- 18.0 ELCB/RCCB stabilizer.
- 19.0 Boiler Suit for PE Fusion technician.

	TOOLS AND EQUIPMENT TO BE PROVIDED BY THE CONTRACTOR PE LAYING	DOCUMENT NO.	Rev
		11-0269-02-07-02-047	0
		Page 2 of 2	

**AAVANTIKA GAS LIMITED
CITY GAS DISTRIBUTION PROJECT**

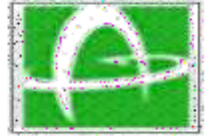

WARNING TAPE

CLIENT JOB NO.

TOTAL SHEETS

04

DOCUMENT NO

11

0269

01

07

02

018

--	--	--	--	--	--

REV	DATE	DESCRIPTION	PREP	CHK	APPR
0	18.10.09	ISSUED FOR CLIENT COMMENTS	AP	SB	SB
A	16.10.09	ISSUED FOR IDC	AP	SB	SB

TECHNICAL SPECIFICATION FOR WARNING TAPE

	WARNING TAPES	DOCUMENT NO.	Rev
		11-0269-01-07-02-018	0
		Page 2 of 4	

TABLE OF CONTENTS

1.0 OBJECT.....4

2.0 FEATURES.....4

3.0 TESTS4

4.0 PACKAGING.....4

	WARNING TAPES	DOCUMENT NO.	Rev
		11-0269-01-07-02-018	0
		Page 3 of 4	

1.0 OBJECT

This Specification refers to the grid of Plastic Material Film which is laid in the ground above the gas mains, in order to indicate their presence.

2.0 FEATURES

a. Material

The Warning tape shall be made of Polyvinyl chloride or Polyethylene and shall be coloured throughout. The Ultimate Tensile Strength of film should not be less than 12 N/mm²

b. Colour

The grid shall be of a bright Golden yellow colour. This colour must not take any appreciable alteration in the course of time.

c. Dimensions

Width : 300 mm ± 5 mm

Thickness : 300 microns.

d. Marking.

Marking on the film should be as approved by OWNER/ OWNER REPRESENTATIVE.

3.0 TESTS

The manufacturer shall proceed to the following tests:

a. Colour-Fast Test

A test specimen 100 mm to 150 mm wide shall be immersed in a 20% solution of ammonium sulphide.

Temperature: 15 to 20°C

Duration or Immersion: 15 days

The colour fastness shall be evaluated by comparing the test specimen with a sample specimen; the comparison shall be made by placing the two specimens on a whit background, in daylight, but without exposing them directly to sunlight. The test shall be deemed satisfactory if the colour of the strip remains intact.

4.0 PACKAGING

The warning grid shall be delivered in rolls of 200 Mtr.

	WARNING TAPES	DOCUMENT NO.	Rev
		11-0269-01-07-02-018	0
		Page 4 of 4	

**AAVANTIKA GAS LIMITED
CITY GAS DISTRIBUTION PROJECT**

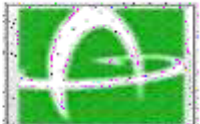

APPLIANCE BALL VALVES					CLIENT JOB NO.	-
					TOTAL SHEETS	04
DOCUMENT NO	11	0269	01	07	02	035

--	--	--	--	--	--

0	18.10.09	ISSUED FOR CLIENT COMMENTS	AP	SB	SB
A	16.10.09	ISSUED FOR IDC	AP	SB	SB
REV	DATE	DESCRIPTION	PREP	CHK	APPR

TECHNICAL SPECIFICATION FOR APPLIANCE BALL VALVES

	APPLIANCE BALL VALVES	DOCUMENT NO.	Rev
		11-0269-01-07-02-035	0
		Page 2 of 4	

TABLE OF CONTENTS

1.0 SCOPE4
2.0 DESIGN CONDITIONS.....4
3.0 VALVE DATA.....4

	APPLIANCE BALL VALVES	DOCUMENT NO.	Rev
		11-0269-01-07-02-035	0
		Page 3 of 4	

1.0 SCOPE

This specification refers to the requirement of Appliance Valve to be suited to connect flexible rubber hose for supply of natural gas to domestic/ commercial consumers.

2.0 DESIGN CONDITIONS

Pressure (mili Barg) 35
Temperature(0C) : 0 – 45

3.0 VALVE DATA

Construction design : ANSI B 16.33

Type : Full Bore – Open/ Close at 90⁰.

End connection : NPT Female (conforming to ANSI B 1.20.1). Female as an inlet (1/2") & the Outlet shall be having Ni/Cr plated brass or steel nozzle to suit Flexible Rubber Tube as per IS 10908.

Body material : Hot Pressed / Forged Brass, Nickel / Chrome Plated.

Ball material : Hard Nickel / Chrome Plated, Hot Pressed / Machined Brass Bars with Teflon Seat.

Others : With Mechanical Operating/Knob/lever.

Mechanical Strength : -The body of the valve shall withstand without Deformation or leakage a min torque of 125 Nm.

- Valve shall be capable of withstanding deformation or leakage 125 Nm bending moment or an angular displacement of 10⁰ whichever occurs first, if applied to a pipe connected to the valve.

-The valves shall be capable of withstanding 25 Nm impact without breakage or leakage.

Testing : Hydro Test & Leak Test

- Leak test shall be carried out either with nitrogen or air

	APPLIANCE BALL VALVES	DOCUMENT NO.	Rev
		11-0269-01-07-02-035	0
		Page 4 of 4	

AAVANTIKA GAS LIMITED
CITY GAS DISTRIBUTION PROJECT

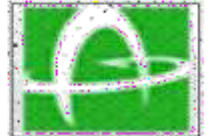

GI FITTINGS					CLIENT JOB NO.		
					TOTAL SHEETS		05
DOCUMENT NO	11	0269	02	07	02	013	

--	--	--	--	--	--	--

0	18.10.09	ISSUED FOR CLIENT COMMENTS		AP	SB	SB
A	16.10.09	ISSUED FOR IDC		AP	SB	SB
REV	DATE	DESCRIPTION		PREP	CHK	APPR

GI FITTINGS

	GI FITTINGS	DOCUMENT NO.	Rev
		11-0269-02-07-02-013	0
		Page 2 of 5	

TABLE OF CONTENTS

1.0 SCOPE4

2.0 MATERIAL4

3.0 DIMENSIONS & DIMENSIONAL TOLERANCES.....4

4.0 THREADS4

5.0 FREEDOM FROM DEFECTS4

6.0 GALVANIZING4

7.0 PRESSURE TEST5

8.0 COMPRESSION TEST5

9.0 SAMPLING5

	GI FITTINGS	DOCUMENT NO.	Rev
		11-0269-02-07-02-013	0
Page 3 of 5			

1.0 SCOPE

This specification cover the requirements for Malleable Cast Iron Fittings unless modified by this specification, requirements of IS 1879 - 1987 shall be valid.

2.0 MATERIAL

The material used for the manufacturing of GI pipes shall conform to 1SI 2108 — 1977 grade BM 290.

3.0 DIMENSIONS & DIMENSIONAL TOLERANCES

- i. Dimensions of various types of fittings shall be as specified in sections 2 to 10 of IS 1879- 1987, as applicable.
- ii. Wall thickness of fittings and tolerances on them shall be as given in Table 1.2 of IS 1879-1987.
- iii. In case of reducing fittings, the dimensions at each outlet shall be those appropriate to the nominal size of the outlet.
- iv. Elbows, Tees, Sockets and caps shall be of reinforced type.

4.0 THREADS

- i. Outlets of fittings shall be threaded to dimensions & the tolerances as specified in IS: 554— 1975.
- ii. All internal & external threads shall be tapered.
- iii. For checking conformity of threads gauging practice in accordance with IS: 8999-1979 shall be followed.
- iv. Chamfering: The outlet of fittings shall have chamfer. The chamfer shall have an included angle of $90^{\circ} \pm 5^{\circ}$ for internal threads & $70^{\circ} \pm$ for external threads.

5.0 FREEDOM FROM DEFECTS

On visual examination, the inside & outside surfaces of fittings shall be smooth & free from any defects such as cracks, injurious flaws, fine sand depth etc.

6.0 GALVANIZING

- i. Fittings shall be galvanized to meet the requirements of IS: 4759-1996.
- ii. Zinc conforming to any grade specified in IS: 209-1992 or IS: 13229-1991 shall be used for the purpose of galvanizing.
- iii. Galvanizing bath: - The molten metal in the galvanizing bath shall contain not less than 98.5% by mass of zinc.
- iv. Coating requirements:- Mass of coating shall be 700 gms/m^2 .
- v. Freedom from defect:- The zinc coating shall be uniform adhered, reasonably smooth & free from such imperfections as flux, ash bare patches, black spots, pimples, lumpiness runs, rust stains, bulky white deposits & blisters.
- vi. Samplings:

	GI FITTINGS	DOCUMENT NO.	Rev
		11-0269-02-07-02-013	0
		Page 4 of 5	

- a) All materials of the same type in coating bath having uniform coating characteristics shall be grouped together to continue a lot. Each lot shall be tested separately for the various requirements of the specification. The number of units to be selected from each lot for this purpose shall be as given in Table 2 of IS: 4759-1996.
- b) The sample selected according to Column 1 & 2 of Table 2, IS: 4759- 1996 shall be tested for visual requirements as per V (v).
- c) The sample found conforming to above requirements shall then be tested for mass of zinc coating in accordance with Clause 9.2 of IS: 4759-1996.
- d) Criteria for conformity: As per Clause 8.3 of IS: 4759-1996.
- e) Test procedure shall be as per Clause 9 of IS 4759-1996.

7.0 PRESSURE TEST

Pneumatic pressure test as per Clause 11.1b of IS: 1879-1987 shall be carried out on each & every fittings. Vendor to submit the Internal Quality control certificate for the same. OWNER/ OWNER REPRESENTATIVE shall witness pneumatic testing as per the sampling procedure specified in IS 1879-1987.

8.0 COMPRESSION TEST

As per clause 12 of IS: 1879-1987.

9.0 SAMPLING

OWNER representative or Third Party Inspection Agency appointed by OWNER shall witness the tests as per clause 14 of IS: 1879-1987. However, vendor to perform 100% inspection of visual, dimensional & pressure test.

Vendor shall furnish Internal test certificates at the time of final inspection by OWNER.

	GI FITTINGS	DOCUMENT NO.	Rev
		11-0269-02-07-02-013	0
		Page 5 of 5	

**AAVANTIKA GAS LIMITED
CITY GAS DISTRIBUTION PROJECT**



GI PIPES					CLIENT JOB NO.		
					TOTAL SHEETS		05
DOCUMENT NO	11	0269	02	07	02	012	

--	--	--	--	--	--

0	18.10.09	ISSUED FOR CLIENT COMMENTS	AP	SB	SB
A	16.10.09	ISSUED FOR IDC	AP	SB	SB
REV	DATE	DESCRIPTION	PREP	CHK	APPR

GI PIPES

	GI PIPES	DOCUMENT NO.	Rev
		11-0269-02-07-02-012	0
		Page 2 of 5	

TABLE OF CONTENTS

1.0	SCOPE	4
2.0	MATERIAL	4
3.0	DIMENSIONS & DIMENSIONAL TOLERANCES.....	4
4.0	THREADS.....	4
5.0	FREEDOM FROM DEFECTS	4
6.0	GALVANIZING.....	4
7.0	POWDER COATING	5
8.0	PRESSURE TEST	5
9.0	MARKING	5
10.0	INSPECTION / DOCUMENTS.....	5

	GI PIPES	DOCUMENT NO.	Rev
		11-0269-02-07-02-012	0
		Page 3 of 5	

1.0 SCOPE

This specification covers the requirements for GI pipes of medium grade. Unless modified by this specification, requirements of IS 1239 (Part-I), 1990 shall be valid.

2.0 MATERIAL

The material used for the manufacturing of GI pipes shall confirm to ISI 1387:1967.

3.0 DIMENSIONS & DIMENSIONAL TOLERANCES

The dimensions & nominal mass of tubes shall be in accordance with Table 2 subject to the tolerances permitted in CL.8.1 & 9 of IS 1239 (Part-I) : 1990. The pipes shall be supplied in 3 Meters length.

4.0 THREADS

- i. Unless specified otherwise, tubes shall be supplied, screwed with taper threads.
- ii. External threads shall be tapered & confirmed to ASME B1.20.1.
- iii. For checking conformity of threads gauging practice in accordance with ASME B1.20.1.

5.0 FREEDOM FROM DEFECTS

On visual examination the outside & inside surfaces of pipes shall be smooth & free from defects such as cracks etc.

6.0 GALVANIZING

Pipes shall be galvanized to meet the requirement of IS:4736-1986.

- ii. Zinc confirming to any grade specified in IS:4736-1986 shall be used for the purpose of galvanizing.
- iii. Galvanizing bath: - The molten metal in the galvanizing bath shall contain not less than 98.5% by mass of zinc.
- iv. Coating requirements:- Mass of coating shall be 400 gms/m².
- v. Freedom from defect:- The zinc coating shall be uniform adhered, reasonably smooth & free from such imperfections as flux. ash bare patches, black spots, pimples, lumpiness runs, rust stains, bulky white deposits & blisters.
- vi. Samplings:
 - a) All materials of the same type in coating bath having uniform coating characteristics shall be grouped together to continue a lot. Each lot shall be tested separately for the various requirements of the specification. The number of units to be selected from each lot for this purpose shall be as given in IS:4711.
 - b) The sample selected according to Clause 6.1 & 6.2 of IS:4736-1986.
 - c) The sample found conforming to above requirements shall then be tested for mass of zinc coating in accordance with Clause 5.1 of IS:4736-1986.
 - d) Criteria for conformity : As per IS:4736 -1986.
 - e) Test procedure shall be as per IS:4736 -1986.

	GI PIPES	DOCUMENT NO.	Rev
		11-0269-02-07-02-012	0
		Page 4 of 5	

7.0 POWDER COATING

Pure Polyester Powder coating to be done on Galvanised pipe as per specification No. 011-290-02-07-02-014.

8.0 PRESSURE TEST

Hydrostatic pressure test shall be carried out at a pressure of 5 Mpa. Vendor to submit the internal pressure test certificate for the same. If required, OWNER representative or Third party Inspection agency appointed by OWNER/ OWNER REPRESENTATIVE shall witness finish goods testing as per the sample procedure specified Cl.14 of IS:1239 (Part-I)-1990.

9.0 MARKING

Each pipe shall be embossed with manufacturer’s name or trademark & the size designation at the interval of not more than 2 meters.

Each packing containing pipes shall carry the following stamped or written by indelible ink.

- a) Manufacturers name or trademark.
- b) Designation of pipe.
- c) Lot number.

Each pipe conforming to this standard shall also be marked with BIS standard mark.

10.0 INSPECTION / DOCUMENTS

- i. Inspection shall be carried out as per OWNER Technical Specification.
- ii. Contractor shall appoint a TPIA for stage wise inspection off all the supply items and cost of same shall be borne by the contractor.
- iii. Owner representative or Third-Party Inspection Agency appointed by OWNER/ OWNER REPRESENTATIVE shall carry out inspection during manufacturing/final inspection as per mutually agreed program.
- iv. Vendor shall furnish all the material test certificates, proof of approval/ license from specified authority as per specified standard, if relevant, internal test! inspection reports as per OWNER Tech Spec. & specified code for 100% material, at the time of final inspection of each supply lot of material.
- v. Even after third party inspection, OWNER/ OWNER REPRESENTATIVE reserves the right to select a sample of fittings randomly from each manufacturing batch & have these independently tested. Should the results of these tests fall outside the limits specified in OWNER technical specification, then OWNER reserves the right to reject all production supplied from the batch.

	GI PIPES	DOCUMENT NO.	Rev
		11-0269-02-07-02-012	0
		Page 5 of 5	

ISOLATION BALL VALVES						CLIENT JOB NO.	-
						TOTAL SHEETS	04
DOCUMENT NO	11	0269	01	07	02	034	

--	--	--	--	--	--	--

0	18.10.09	ISSUED FOR CLIENT COMMENTS	AP	SB	SB
A	16.10.09	ISSUED FOR IDC	AP	SB	SB
REV	DATE	DESCRIPTION	PREP	CHK	APPR

TECHNICAL SPECIFICATION FOR ISOLATION BALL VALVES

	ISOLATION BALL VALVES	DOCUMENT NO.	Rev
		11-0269-01-07-02-034	0
		Page 2 of 4	

TABLE OF CONTENTS

1.0 SCOPE 4

2.0 DESIGN CONDITIONS..... 4

3.0 VALVE DATA..... 4

	ISOLATION BALL VALVES	DOCUMENT NO.	Rev
		11-0269-01-07-02-034	0
		Page 3 of 4	

1.0 SCOPE

This specification refers to the requirement of Isolation Ball Valves to be installed before Meter for the supply of natural gas to domestic/ commercial consumers.

2.0 DESIGN CONDITIONS

Pressure (Barg) : 4.0
Temperature (⁰C) : 0 – 45

3.0 VALVE DATA

Construction design : ANSI B 16.33

Type : Full Bore – Open/ Close at 90⁰.

End connection : NPT Female (conforming to ANSI B 1.20.1)

Body material : Hot Pressed / Forged Brass, Nickel / Chrome Plated.

Ball material : Hard Nickel / Chrome Plated, Hot Pressed / Machined Brass Bars with Teflon Seat.

Others : With Operating Knob and locking arrangement with sealing Wire.

Mechanical Strength : -The body of the valve shall withstand without Deformation or leakage a min torque of 125 Nm.

- Valve shall be capable of withstanding deformation or leakage 340 Nm bending moment or an angular displacement of 10⁰ whichever occurs first, if applied to a pipe connected to the valve.

-The valves shall be capable of withstanding 25 Nm impact without breakage or leakage.

Testing : Hydro Test Pressure
Leak test

- Leak test shall be done either with nitrogen or Air at design pressure.

- Hydrotest to be done at 1.5 times the design pressure.

	ISOLATION BALL VALVES	DOCUMENT NO.	Rev
		11-0269-01-07-02-034	0
		Page 4 of 4	

AAVANTIKA GAS LIMITED
CITY GAS DISTRIBUTION PROJECT

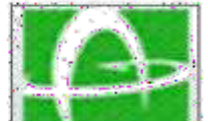

TECHNICAL SPECIFICATION FOR INSTALLATION OF ABOVE GROUND GI PIPING & FITTING					CLIENT JOB NO.		
					TOTAL SHEETS		13
DOCUMENT NO	11	0269	02	07	02	033	

--	--	--	--	--	--	--

0	18.10.09	ISSUED FOR CLIENT COMMENTS		AP	SB	SB
A	16.10.09	ISSUED FOR IDC		AP	SB	SB
REV	DATE	DESCRIPTION		PREP	CHK	APPR

TABLE OF CONTENT

1.0	General Information.....	3
2.0	Scope of Work.....	3
3.0	Material, Labour, Plant and Equipment	4
4.0	Issue of Work Instructions	5
5.0	Progress of work.....	6
6.0	Work Sheets	6
7.0	Permissions / approvals.....	6
8.0	Reference Specification, Codes and standards.....	7
9.0	Safety	7
10.0	Right of use survey and marking	7
11.0	Protection of Structures and Utilities	8
12.0	GI above ground service pipe.....	8
13.0	Testing of GI installation	9
14.0	Inspection	10
15.0	Purging and Commissioning	10
16.0	Installation of Meters	11
17.0	Painting of GI pipes	11
18.0	Box for regulator.....	11
19.0	Conversion of Domestic Appliances	12
20.0	Restoration	12
21.0	Submission of final records.....	13

	TECHNICAL SPECIFICATION FOR INSTALLATION OF ABOVE GROUND GI PIPING & FITTING	DOCUMENT NO.	Rev
		11-0269-02-07-02-033	0
	Page 2 of 13		

INSTALLATION OF ABOVE GROUND GI PIPING & FITTING

1.0 General Information

1.1 Introduction

AGL plans to install an underground Natural Gas Distribution network throughout the city of Indore. The object is to supply Natural Gas to Industrial, Domestic and Commercial Customers and to provide compressed gas as fuel for automobiles. AGL is seeking Contractors to assist in meeting the above objective.

The main scope of this contract comprises of supply and installation of above ground pipes from the outlet of PE/GI transition fitting upto the Domestic / Commercial customers "Applicable / stove / oven valve" as per the Distribution schedule placed with drawing no. WGI-01-P-0-104.

The scope includes supply and installation of above ground GI/ Copper pipes and associated fittings, valves etc. installation of OWNER supplied regulator and meter for domestic and commercial customers.

This technical specification defines the basic guidelines to develop an acceptable design and suitable construction methodology for carrying out different activities listed out in the schedule of rates of this tender.

Compliance with these specifications and / or approval of any of the Contractor's documents shall in no case relieve the Contractor of his contractual obligations.

2.0 Scope of Work

Generally, the following shall constitute the contractor's scope of work

- 2.1 Plan and prepare a detailed execution schedule and procedure for implementation based on QA/QC formats plans issued by AGL/ WGI.
- 2.2 Supply of GI pipes, fittings, valves, flexible hoses, clamps and other required materials required to complete the work, receipt of owner supplied regulators, meters and other free issue items from AGL stores, loading, transportation, unloading at project sites. Proper storing, stacking, identification, providing security, and insurance, during and before installation and commissioning of pipelines. Obtaining the approval for optimum route and permission for work from the concerned authority and EIC.
- 2.3 Selection of route and marking on walls / floors between "transition fitting" to "cooking oven / stove / appliance making openings and making provisions for fixing clamps. Making temporary but stable platforms / scaffolding / rope ladder etc., required for installation of pipes / fittings at all heights / multi storied flats and locations.
- 2.4 Installation of GI Pipes of 3/4", 1", 1 1/2" dia. between transition fittings to customer's kitchen appliances or up to Copper connectors including NPT threading of pipes, supply of proper seal outs for threads, to join fittings such as elbows, tees, connectors, regulators, meters, isolation valves, etc., as per laid procedures and specification including clamping and sealing, etc.
- 2.5 Supply of clamps for fixing pipes, box for regulator wherever required, painting of GI pipes & fittings. Providing consumables grout material, repair / restoration of walls / floors changes for the pipes including the materials required for conversions and tools and tackles, etc., complete as per specification.
- 2.6

	TECHNICAL SPECIFICATION FOR INSTALLATION OF ABOVE GROUND GI PIPING & FITTING	DOCUMENT NO.	Rev
		11-0269-02-07-02-033	0
	Page 3 of 13		

- 2.7 Testing & Commissioning of installations including purging as per specification and handing over the installation of AGL / customer to the entire satisfaction of AGL / WGI.
- 2.8 Dismantling of scaffolding / temporary structures and cleaning of site.
- 2.9 Restoration of walls, flooring and other damages while executing the above ground installation.
- 2.10 Preparation and submission of above ground installation card for each house / commercial establishment indicating the list of material used, reasons of not providing connections, testing, etc. and deviation statements on completion / commissioning of work.
- 2.11 Any other activity (ies) not mentioned / covered explicitly above, but otherwise required for satisfactory completion / operation / safety / statutory / maintenance of the works shall also be covered under the Scope of work and has to be completed by the Contractor within specified scheduled at no extra cost to AGL.
Contractor must Supply & install isolation valve before and After Non-domestic meter (installation of MCV).

3.0 Material, Labour, Plant and Equipment

3.1 Owner Supply Material

All Regulators and meters shall be supplied by AGL to the contractor free of charge.

3.2 Contractor Supply Material

The contractor shall supply all GI pipes, fittings, valves as per specification attached with the bid document and provide labour, tools (such as Hammer Drill, Piston Drill, Pipe cutters, Dies for threading, pipe wrenches, spanners, conversion kits, solder torch, GI cutter, thinner etc.), all types of clamps of, plant and equipment necessary for the proper execution of the work. This will include but not be limited to list of specialized tools & tackles indicated in Annexure – II

Owner reserves the right to inspection of contractor supplied materials (bought –out materials) at any stage of production in plant/ shop/ warehouse. Contractor has to arrange these inspections with all the required equipment, without any extra cost to the owner. The traveling and lodging charges for OWNER/ OWNER's representative persons shall be in the scope of OWNER.

the Contractor shall submit the specification and Material Receipt Inspection Report of all the material to be supplied by him to EIC for approval before commencing the execution.

3.2.1 Plant and Equipment

All vehicular type machinery shall be in good working condition and shall not cause spillage of oil or grease. To avoid damage to paved surfaces the contractor will provide pads of timber or thick rubber under the hydraulic feet or outriggers of machinery.

3.2.2 Sealant Grout

The contractor shall be responsible to arrange the supply of any consumable sealant or ready mix grout material required for execution of work. The sealant / grout supplied by the contractor shall be compatible with the area to be restored / rectified. No separate payment for the supply of sealant and grout shall be made to the contractor.

3.2.3 Clamps, Rawal Plugs,SS Screws, Nozzels, etc.

	TECHNICAL SPECIFICATION FOR INSTALLATION OF ABOVE GROUND GI PIPING & FITTING	DOCUMENT NO.	Rev
		11-0269-02-07-02-033	0
		Page 4 of 13	

The clamps, Brackets for meter, Nylon rawal plug, SS screw shall be approved lot wise by EIC prior to installation. Screwing should be done by Screw driver only. No hammering is allowed for screwing. The Clamps, Rawal Plugs, SS Screws, Nozzles, etc shall be approved lot wise by EIC prior to installation. Re-drilling of existing appliance nozzles is strictly not permitted. The quality of materials procured will be got approved and will be as directed by EIC.

The indicative sketch of the brackets for Meter and GI pipe clamps Doc no: - 01-P-0-103

3.2.4 Other Materials

The contractor shall supply the following items where required:

- f* All materials required for formwork, NPT threading, Cu pipe jointing, testing etc.
- f* All signs, barricades, lights and protective equipment.
- f* All material required for working at higher floor levels (i.e. scaffolding, ladder, safety belts, etc.)
- f* Special consumable such as grease for maintenance of domestic appliances and all paints for painting of GI Pipes, clamps, sleeves, brackets for meters, consumables such as Teflon Tapes, Petrol, diesel, fuels and oils required are to be supplied by the contractor and are included for within the rates.
- f* All minor items not expressly mentioned in the contract but which are necessary for the satisfactory completion and performance of the work under this contract.

3.3 Acquisition, Receipt and storage of materials

The contractor shall collect all free issue materials from AGL's designated stores and between the hours to be advised by the EIC.

The contractor shall carry pipe in such a manner as to preclude damage during transportation and handling.

The contractor shall at the time of acceptance physically examine all materials and notify the EIC immediately of any damage or defect noticed by the contractor. The EIC shall duly note any damage or defect in a site instruction book and both parties shall countersign the entry.

Any damage not so recorded will be deemed not to have existed at the time of acceptance by the contractor and the cost of repair or replacement or rectification shall be borne by the contractor.

All materials shall be stored in contractors stores near site in such a manner as to prevent any damage to the materials from either scratching, gouging, indentation, excessive heat or by contact with any sharp objects or chemicals. The contractor shall be required to submit an inventory of materials every month.

4.0 Issue of Work Instructions

The contractor will be required to carry out GI installation in the areas where MDPE laying is under progress. However, testing of GI installation shall be done in conjunction with laying of MDPE service Lines to respective premises. A general scheme of distribution to domestic consumer is indicated in drawing no. WGI-01-P-0-104 for reference. It may vary in case of individual and multistoried flats.

4.1 All skilled personnel like plumbers, conversion technicians shall be approved and certified by EIC. Those who are certified and possess the identity cards duly signed by EIC are only authorized to take up respective jobs. The contractor has to arrange the identity cards.

4.2 The rates to be quoted by contractor shall be inclusive of all preparatory / bye works, platform materials, labor, skills, supervision, tools, taxes, duties, levies, salaries, wages, overheads, profits, escalations

	TECHNICAL SPECIFICATION FOR INSTALLATION OF ABOVE GROUND GI PIPING & FITTING	DOCUMENT NO.	Rev
		11-0269-02-07-02-033	0
	Page 5 of 13		

fluctuations in exchange rates and no change in the rates shall be admissible during tenancy of the contract.

4.3 The schedule of items of SOR have been described in brief and shall be held to be complete in all respect including safety requirements as per clause 9.0, tests, inspection, QA/QC works, enabling and sundry works. The payment shall be made against completed and measured works only. No extra works whatsoever shall be considered in execution of these items.

5.0 Progress of work

The contractor shall proceed with the work under the contract with due expedition and without delay.

The EIC may direct in what order and at what time the various stages or parts of the work under the contract shall be performed.

Weekly progress reports shall be submitted in the formats approved by AGL, indicating broadly the laying testing, RFC conversions and extra piping.

Materials consumption statement to be submitted at least once a month.

6.0 Work Sheets

6.1 The quantities and other details will be checked by AGL/WGI site engineer and the same shall be incorporated in GI cards, signed and dated as certified, on site. The cards will then be approved by the EIC.

6.1 Measurement sheets shall be prepared based on the GI cards and checked and certified by the site engineers for billing purpose.

6.2 If measurement sheets submitted are illegible, incomplete or incorrectly booked they will be returned to the contractor.

7.0 Permissions / approvals

7.1 Contractor shall be responsible for obtaining approval from authorities like Municipal Corporation/PWD and any other concerned authority, if required for completion of the work. Contractor must take the prior appointment from the resident for carrying out the work.

7.2 All statutory fees payable to the statutory authorities in this connection if required shall be paid by AGL on production of documentary evidence.

7.3 The prospective bidder shall work in close consultation / coordination with the EIC and keep fully appraised and informed to the EIC about the various paper / documents, applications being filed with the authorities / utilities as above. A copy of all the documents / application including enclosures duly acknowledged by the authorities / utilities.

7.4 The prospective bidder shall not sign / execute any agreement and / or undertaking on any such documents which amounts to be undertaken by AGL. The same shall only be signed and executed by

7.5 The necessary coordination liaison and arrangements for statutory inspection and approval shall be the contractor's responsibility. Inspection and acceptance of the work by statutory authority shall not relieve the contractor from any of these responsibilities under this contract. AGL will provide the registrations to the contractor for execution of work. However it is the contractor's responsibility to fix a firm appointment with the consumer for carrying out the work and also it is the contractor's responsibility to coordinate with the outside agencies like Municipal Corporation/PWD/SE/ Housing Board or any other authority while

	TECHNICAL SPECIFICATION FOR INSTALLATION OF ABOVE GROUND GI PIPING & FITTING	DOCUMENT NO.	Rev
		11-0269-02-07-02-033	0
		Page 6 of 13	

carrying out work and restoration in Govt. Flats. A log book / job card for such appointments once taken shall be adhered to by the contractor. Project Management / EIC shall review the records every week.

- 7.6 The contractor is also required to obtain a Labour License from the Labour Commissioner /Assistant Labour Commissioner.
- 7.7 It will be the contractor's responsibility to familiarize himself and comply with any other local rules regulations or statutory requirements applicable to the work.
- 7.8 The contractor has to take responsibility of the actions of supervisors, plumbers and helpers provided by him.

8.0 Reference Specification, Codes and standards

The contractor shall carry out the work in accordance with this specification, Aavantika Gas Engineering Standards: ASME B 31.8 – Gas Transmission and Distribution piping Systems; Australian standard 2723 – Installation and Maintenance of Plastics Pipe system for Gas; Oil India Safety Directorate Norms (OISD) and the American Gas Association Document – Purging Principles and practice, PNGRB regulations and specifications.

Should the contractor find any discrepancy, ambiguity or conflict in or between any of the Standards and the contract documents, then this should be promptly referred to the Engineer – In – Charge (EIC) for his decision, which shall be considered binding on the contractor.

9.0 Safety

The contractor shall take care of all safety norms applicable for such works at site. Contractor shall provide all safety appliances eg. Safety helmets, gloves, safety belts, ladders staging, shoes, goggles, etc.

All necessary care shall be taken while working at heights and workmen with proper skills and work permits only shall be deployed. Proper barricading and warning signs shall be installed. Adequate care shall be taken while taking supports from balconies, chajjas / protection parapets and like structures to be sure of strength and adequacy of the same.

No night working shall be permitted without proper lighting and prior approval of EIC.

10.0 Right of use survey and marking

The route of the pipeline to be installed shall be decided with consent of the consumer and SE / EIC. Contractor must ensure that the persons / workers / supervisors at site shall have proper identity cards prior to entering the premises of the consumers.

No temporary or permanent deposit of any kind of material resulting from the work shall be permitted in the approach or any other position which might under the passage and / or natural water drainage or any area where there is objection from consumer.

The contractor shall obtain necessary permissions from landowners and tenants and shall be responsible for all damages caused by the construction and use of such approaches, pavements, gardens, rooms, walls, roof, etc at no extra cost to AGL.

A survey will be conducted jointly by AGL / WGI and the contractor at each premises or housing colony to be supplied the natural gas. The survey recorded will note the customer details, the potential gas supply points and proposed meter position and estimate of material quantities. The contractor's representatives will make a sketch of the agreed pipe routes, if necessary.

The contractor will be responsible for contacting the customer and making the necessary arrangements for access and appointments to carry out the work. AGL will not be responsible for any time lost due to broken appointments or disputes with customers.

	TECHNICAL SPECIFICATION FOR INSTALLATION OF ABOVE GROUND GI PIPING & FITTING	DOCUMENT NO.	Rev
		11-0269-02-07-02-033	0
	Page 7 of 13		

The contractor shall confine its operations within limits of the right of use. Any damage to property outside ROW shall be restored by the contractor.

The contractor shall also carryout all necessary preparatory work if needed to permit the passage of men and equipment. Lights, curbs, signs shall be provided wherever and / or required by the AGL necessary to protect the public.

11.0 Protection of Structures and Utilities

The contractor shall at his own cost, support and protect all buildings, walls, fences or other structures and all utilities and property which may, unless so protected be damaged as a result of the execution of the work. He shall also comply with the requirements in the specification relating to protective measures applicable to particular operations or kind of work.

While painting contractor must take care of the consumer premises while carrying out the job / such as spillage on floor, walls, ceilings, sun shades, etc. If the same does occur, the contractor is to immediately make good to original.

12.0 GI above ground service pipe

The GI service pipe installation work includes all work necessary to connect from the PE / GI transition fitting on the down-stream of the PE service, to the customers appliance, including the installation of regulator and valves, except meters for which separate rate shall be paid as per SOR of this document. The contractor shall be required to provide all equipment, tools and materials necessary to execute the work in an efficient and effective manner. Amongst other things they shall be required to provide ladders, scaffolding pipe, dies, tripods, vices, fittings and Teflon tape, drills for concrete and other masonry, drills for timber and laminated surfaces inside customers property, bending tools, clamps, sleeves to facilitate the pipe passing through floors and walls, paint for pipe marking etc. GI pipes, fittings valves, transition fittings, hoses etc. for meter has to be supplied by Contractor as per specification attached and **regulator** shall be provided by AGL. Use of sleeves for laying steel pipe through wall / or under outer wall foundations of building or under the building is not permitted. Such underground lines shall be protected against corrosion by minimum 400 micron thick 2 pack high build epoxy coating.

All GI risers on the outside of buildings shall be fully supported to carry the weight of piping. Risers shall be supported by a flanged foot, or similar device, capable of supporting the total weight of the riser. The riser shall rise in a vertical line from its point of support to its highest point with a minimum of changes in direction. The threading of GI pipes shall be NPT and conforming to ASME / ANSI B1 20.1. Wherever the service line riser is installed in confined spaces like basements, only welded risers shall be used. The gap between riser & wall shall be minimum 25mm and shall be supported at every 2 meter. Ventilators shall be provided in confined space.

Contractor has to supply different types / sizes of approved clamps (mild steel) for fixing GI pipes suiting to the site conditions and the same shall be painted before fixing, as per the painting specifications Every fresh lot of the materials including Pipes, fittings, valves clamps, brackets, regulator boxes and other consumables shall be approved by the EIC prior to start of installation. All riser and lateral pipe shall be clamped to the building at intervals not exceeding two meters.

Where pipe passes through a balcony floor, the floor surface shall be made slightly elevated around the service pipe or its surrounding sleeve to prevent the accumulation of water at that point. Where a short piece of sleeve is used around the gas pipe, the sleeve should be embedded in the concrete with a mix of mortar and the void between the pipe and sleeve filled with a suitable sealant. The sealant should be beveled such as to prevent an accumulation of water. Supply of clamps for all sizes of the GI pipes is in contractor's scope. Contractor has to take prior approval for design of clamps, paintings etc.

Pipe shall preferably enter a building aboveground and remain in a ventilated location. The location for entry shall be such that it can be routed to the usage points by the shortest practicable route.

The rates are to be paid as per item of SOR. The pipe installation includes the supply and installation of all pipes, fittings, valves, flexible hoses for meter connections and installation of regulators, etc. and painting of the pipes.

	TECHNICAL SPECIFICATION FOR INSTALLATION OF ABOVE GROUND GI PIPING & FITTING	DOCUMENT NO.	Rev
		11-0269-02-07-02-033	0
	Page 8 of 13		

All riser and lateral pipe shall be clamped to the building at intervals not exceeding one meter.

Where pipe passes through a balcony floor, the floor surface shall be made slightly elevated around the service pipe or its surrounding sleeve to prevent the accumulation of water at that point. Where a short piece of sleeve is used around the gas pipe, the sleeve should be embedded in the concrete with a mix of mortar and the void between the pipe and sleeve filled with a suitable sealant. The sealant should be beveled such as to prevent an accumulation of water. Supply of clamps for all sizes of the copper pipes is in contractor's scope. Contractor has to take prior approval for design of clamps, paintings, etc.

Pipe shall preferably enter a building aboveground and remain in a ventilated location. The location for entry shall be such that it can be routed to the usage points by the shortest practicable route.

The rates are to be paid as per item of SOR. The pipe installation includes the supply and installation of all GI pipes, GI fittings, Isolation ball valves, Meter clamp at every Non Domestic meter connections and painting of the pipes.

After installation of the entire piping system, final painting shall be done to the satisfaction of EIC.

13.0 Testing of GI installation

- 13.1 The installation from PE / GI transition fitting upto regulator shall be tested at the pressure of 6.0 bar (g).
- 13.2 The GI installation from regulator out let to appliance valve (except meter) shall be tested at a pressure of 2.0 bar (g) for a hold period of 4 hour and all the joints shall be checked with soap solution.
- 13.3 The Copper installation from GI out let to appliance valve (except meter) shall be tested at a pressure of minimum two times the operating pressure with U- tube manometers for a hold period of minimum 15 minutes and all the joints shall be checked with soap solution. Testing to be carried out with the entire satisfaction of SE/ EIC.

	TECHNICAL SPECIFICATION FOR INSTALLATION OF ABOVE GROUND GI PIPING & FITTING	DOCUMENT NO.	Rev
		11-0269-02-07-02-033	0
	Page 9 of 13		

- 13.4 The meter shall be removed while carrying out the testing and joints of the meter shall be tested on line with soap solution after completion of the work. Proper test ends shall be made along with gauges and got approved by EIC.
- 13.5 Anaconda, valves shall not be used for testing purpose.
- 13.6 The calibrated pressure gauges of suitable range shall be supplied by the contractor for testing.
- 13.7 The pressure gauges shall be calibrated from time to time as desired by EIC but positively once in an every six months.
- 13.8 The details of testing shall be properly recorded in the GI / CU Cards.

14.0 Inspection

Any defect noticed during the various stages of inspection shall be rectified by the contractor to the entire satisfaction of EIC before proceeding further. Irrespective of the inspection, repair and approval at intermediate stages of work, contractor shall be responsible for making good any defects found during final inspection / guarantee period / defect liability period as defined in general condition of contract.

15.0 Purging and Commissioning

Payment for the tapping of live mains and GI piping prior to the actual purge is included in item of SOR. This rate is to cover the extra work necessary to make the connection. The payment will be a one off payment regardless of the number of service pipes connected downstream, which may need stopping off as part of the purging process. The connection may involve the fitting of a temporary bypass, disconnection, etc. the cost of which shall be included in the connection rate.

Purging shall be carried in accordance with the principles defined in the American Gas Association Publication "Purging Principles and Practice".

In addition the contractor shall submit and have approved purging plan before commencing any purging work. The plan shall include, but not be limited to the provision of the following materials and equipments; personal safety equipment, fire extinguisher, purging adapter, purge stack with flame trap and gas sampling point, Gas sampling equipment (may be gas leak detector), squeeze tool, polyethylene connecting pipe work etc.

The plan shall also include the purging process along with detail on the sequence of events. The process is to also specially mention the need to lay a wet cloth over the GI pipe and in contact with the ground to disperse static electricity during the purging work.

A purging stack with flame trap shall be used when purging services. Care shall be taken to ensure that the purge outlet is so located that vent gas cannot drift into buildings.

The purging work should be performed as follows:

- 15.1 Ensure the method of purging is such that no pockets of air are left in any part of the customers piping.
- 15.2 Ensure that all appliance connections are gas tight, all appliance gas valves are turned off and there are no open ends.
- 15.3 Where possible, select an appliance with an open burner at which to commence the purge i.e. a hotplate burner.
- 15.4 Ensure the area is well ventilated and free from ignition sources.
- 15.5 Ensure branches that do not have an appliance connected are fitted with a plug or cap.

	TECHNICAL SPECIFICATION FOR INSTALLATION OF ABOVE GROUND GI PIPING & FITTING	DOCUMENT NO.	Rev
		11-0269-02-07-02-033	0
		Page 10 of 13	

- Turn on one burner control valve until the presence of gas is detected. A change in the audible tone and smell is a good indication that gas is at the burner. Let the gas flow for a few seconds longer, then turn off and allow sufficient time for any accumulated gas to disperse.
- Turn on one gas control valve again and keep a continuous flame at the burner until the gas is alight and the flame is stable.
- Continue to purge until gas is available at other appliances.

16 Installation of Meters

The work in this section includes:

- 17.1.1 Installation of domestic and non-domestic / small commercial meters with associated inlet and outlet connection, on the wall with approved meter brackets and angles. This work is payable under SOR item.
- 17.1.2 Supply of approved meter brackets and angle brackets, properly painted with one coat of Zinc primer and two coats of synthetic enamel paint of approved make. A sketch of the brackets is enclosed for reference drawing no. WGI-01-P-0-103. It is required that one sample of each type of bracket is got approved beforehand.
- 17.1.3 Firmly securing the meters on the wall with good quality supply of proper rowel, plugs, SS screws etc. In case the rowel plugs are not holding than wooden blocks or other fixing arrangements like cement, etc to be used for proper grouting.
- 17.1.4 The same rates of SOR item will apply irrespective of whether the meter is situated inside or outside the property. Where a bank of meters is constructed the rate shall be for each complete meter installed.
- 17.1.5 The above activities along with restoration of the area to original shall be carried out to the complete satisfaction of consumer and EIC.

17 Painting of GI pipes

The entire length of the pipeline along with fittings and clamps are to be painted after proper surface preparation and painting as follows:

One coat of primer application (appropriate Zinc based primer).

Two coats of synthetic enamel paint – canary yellow of minimum of 30 microns per coat of reputed make like Asian, Berger, Nerolac.

All painting materials including primers and thinners brought to site by contractor for application shall be procured directly from manufacturers / dealers as per specifications and shall be accompanied by manufacturer’s test certificates. Pain formulations without certificates are not acceptable.

EIC at his discretion may call for tests for paint formulations. Contractor shall arrange to have such tests performed including batch wise test of wet paints for physical and chemical analysis. All costs there shall be borne by the contractor.

The painting work shall be subject to inspection and certification by EIC at all times.

After installation of the entire piping system, final touching shall be done to the satisfaction of EIC.

18 Box for regulator

Boxes will be supplied and installed outside for regulators after due approval of the sample. The boxes will be installed as per requirement and as per instructions of AGL.

The box brackets are to tightly secured to the wall with good quality proper Rowel plugs, SS screws etc. Wooden blocks to be used in case rowel plugs, do not hold properly.

	TECHNICAL SPECIFICATION FOR INSTALLATION OF ABOVE GROUND GI PIPING & FITTING	DOCUMENT NO.	Rev
		11-0269-02-07-02-033	0
		Page 11 of 13	

All the boxes shall be thoroughly cleaned, painted with approved colour code.

As the boxes are installed outside it is to be ensured that they are painted properly to avoid rusting / weathering.

A sketch of regulator box is enclosed at drawing no. WGI-01-P-0-103.

19 Restoration

Backfilling activity shall include proper compaction by manual/ jumping jack compactor and watering in layers of 150 mm above the warning mat.

Proper crowning of not more than 150mm shall be done. All the excavated material required to be used during the Restoration process shall be stacked and kept separately and properly.

Wherever Road cutting/Tiles removal/PC cutting has been done during excavation for laying, the area shall be backfilled and compacted immediately so that no inconvenience is caused to the general public.

Backfill, sub-base and road-base materials shall be placed in layers of a maximum un-compacted thickness of 100 mm and compacted, using 4 passes of a suitable hand rammer. Each layer of material will be watered in as it is laid to ensure that an optimum moisture content is maintained.

The slabs or blocks should be laid on moist bedding material, which should be graded sand, mortar or a mortar mix. The bedding material shall be spread over the whole area of the sub-base to match the existing thickness, or to a minimum of 25 mm.

The slabs or blocks should be tapped into position to ensure that they do not rock after laying. The reinstated slabs or blocks should match the surrounding surface levels and adjacent slabs with ± 6 mm throughout.

The joints between the slabs or blocks will be filled with a dry or wet mix to match existing. Joint widths should be laid to match the existing surface.

If, it is found that restoration done by contractor is not as per specification then AGL/ Consultant may ask the contractor for rework without any extra payment.

Contractor has to restore the area where ever he has carried out drilling, clamping etc to its original condition to the satisfaction of the consumer and to ensure no passage to the premises and seepage. If the work was carried out in Govt. Flats contractor has to restore the area according the CPWD specifications. For government flats the contractor has to obtain a clearance certificate from the concerned authorities maintaining the flats, after completion of work.

Where slabs and brick work are to be reinstated, the level of the compacted sub-base is to be adjusted according to the slab / block thickness. The slabs or brick work should be laid on moist bedding material, which should be graded sand, mortar or mortar mix. The slabs or brick work should be tapped into position.

The restored slabs or brick work should match the surrounding surface levels. Joint widths should match the existing conditions, and be filled with a dry or wet mix of mortar.

The contractor will be responsible for the maintenance of all restoration carried out, for the duration of the contract guarantee period.

20 Submission of final records

Contractor shall submit the following documents in three sets each

- 20.1 Total list of houses and commercial establishments in the area allotted to him giving details of connections provided and reasons where connection could not be given / completed.
- 20.2 The details recorded in GI cards of every domestic house.
- 20.3 Details of houses where extra piping done along with materials used.
- 20.4 Total material consumption report.
- 20.5 Material reconciliation with respect to the free materials issued.
- 20.6 Test reports and test certificates of gauges etc.

Any other documents / records required.

	TECHNICAL SPECIFICATION FOR INSTALLATION OF ABOVE GROUND GI PIPING & FITTING	DOCUMENT NO.	Rev
		11-0269-02-07-02-033	0
	Page 13 of 13		

**AAVANTIKA GAS LIMITED
CITY GAS DISTRIBUTION PROJECT**

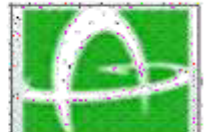

TOOLS AND EQUIPMENT TO BE PROVIDED CONTRACTOR FOR GI / CU WORK					CLIENT JOB NO.	
					TOTAL SHEETS	02
DOCUMENT NO	11	0269	02	07	02	048

--	--	--	--	--	--

0	18.10.09	ISSUED FOR CLIENT COMMENTS	AP	SB	SB
A	16.10.09	ISSUED FOR IDC	AP	SB	SB
REV	DATE	DESCRIPTION	PREP	CHK	APPR

Annexure-II

Tools and Equipment to be provided contractor for GI Work

- 1.0 Gas detection equipment, where required
- 2.0 Cable and pipe locator
- 3.0 Hammer Drill
- 4.0 Power Generator (2.5 KVA)
- 5.0 Piston Drill
- 6.0 Conversion Kit
- 7.0 Pneumatic test pumps
- 8.0 Die sets for thread preparation (NPT)
- 9.0 G.I. cutter
- 10.0 Soldier torch
- 11.0 Cleaning pads
- 12.0 Cleaning brush
- 13.0 Any other equipment / tool required for completion of job.

	Tools and Equipment to be provided contractor for GI / CU Work	DOCUMENT NO.	Rev
		11-0269-02-07-02-048	0
		Page 2 of 2	

**AAVANTIKA GAS LIMITED
CITY GAS DISTRIBUTION PROJECT**

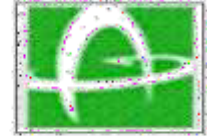

**STANDARD SPECIFICATION FOR HEALTH, SAFETY AND
ENVIRONMENT (HSE) MANAGEMENT AT CONSTRUCTION SITES**

CLIENT JOB NO.

-

TOTAL SHEETS

37

DOCUMENT NO.

11

0269

01

18

02

037

0	18.10.09	ISSUED FOR CLIENT COMMENTS	AP	SB	SB
REV.	DATE	DESCRIPTION	PREP	CHKD	APPD

1.0 SCOPE

This specification establishes the health, Safety and environment (HSE) management requirement to be complied by Contractors during construction.

Requirements stipulated in this specification shall supplement the requirements of HSE management given in relevant Act (s)/legislations, General Conditions of Contract (GCC), Special Conditions of Contract (SCC) and Job (Technical) Specifications. Where different documents stipulate different requirements, the most stringent shall apply.

2.0 REFERENCES

The document should be read in conjunction with following:

- General Conditions of Contract (GCC)
- Special Conditions of Contract (SCC)
- Building and other construction workers (regulation of employment and condition of service) Act,1996
- Job (Technical) specifications
- Relevant IS Codes refer Annexure-
I) Statutory requirements

3.0 REQUIREMENTS OF HEALTH, SAFETY & ENVIRONMENT (HSE) MANAGEMENT SYSTEM TO BE COMPLIED BY BIDDERS

3.1 MANAGEMENT RESPONSIBILITY

3.1.1 HSE Policy & Objectives

The Contractor should have a documented HSE policy & objectives to demonstrate commitment of their organization to ensure health, safety and environment aspects in their line of operations.

3.1.2 Management System

The HSE management system of the Contractor shall cover the HSE requirements including but not limited to what is specified under para 1.0 and para 2.0 above.

3.1.3 Indemnification

Contractor shall indemnify & hold harmless Owner/Consultant & their representatives free from any and all liabilities arising out of non-fulfillment of HSE requirements.

3.1.4 Personnel deployment

Contractor as a minimum requirement shall designate/deploy the following persons at site:

- a) Up to 250 persons
deployed by him at site - Designate one safety supervisor
- b) For 251 to 500 persons - Deploy one qualified & \Experienced safety Engineer/Office in addition to Deployed by him at site the Safety Supervisor as described in (a) above.
- c) For more than 500 persons - Deploy an additional Safety Engineer/ Officer for every 500

	STANDARD SPECIFICATION FOR HEALTH, SAFETY AND ENVIRONMENT (HSE) MANAGEMENT AT CONSTRUCTION SITES	DOCUMENT NO.	REV
		11-0269-01-18-02-037	0
		SHEET 2 OF 37	

Persons or part deployed by him at site thereof, in addition to (b) above.

No work will be started at site until above safety personnel are mobilized at site. The contractor shall submit a safety organogram clearly indicating the lines of responsibility, reporting system and furnish Bio-Data/Resume/Curriculum Vitae with contact details of the safety personnel he intends to mobilize, at least 1 month before the intended mobilization.

3.1.5 Implementation & Monitoring

Contractor shall be fully responsible for planning, implementing and monitoring all HSE requirements and compliance of all laws & statutory requirements. The Contractor shall also ensure that the HSE requirements are clearly understood & faithfully implemented at all levels at site.

3.1.6 Awareness

The Contractor shall promote and develop consciousness about Health, Safety and Environment among all personnel working for the Contractor. Regular awareness programs and fabrication shop/work site meetings shall be arranged on HSE activities to cover hazards involved in various operations during construction.

3.1.7 Fire prevention & First-aid

The contractor shall arrange suitable first aid measures such as First Aid Box (Refer Annexure-II for details), trained personnel to administer First Aid, stand-by ambulance or vehicle and install fire protection measures such as: adequate number of steel buckets with sand & water and adequate number of appropriate fire extinguishers (Refer Annexure-III for details) to the satisfaction of OWNER/CONSULTANT.

3.1.8 Documentation

The contractor shall evolve a comprehensive, planned and documented system for implementation and monitoring of the HSE requirements. This shall be submitted to OWNER/CONSULTANT for approval. The monitoring for implementation shall be done by regular inspections and compliance to the observations thereof. The Contractor shall get similar HSE requirements implemented at his sub-contractor(s) work site/office. However, compliance of HSE requirements shall be the responsibility of the Contractor. Any review/approval by OWNER/CONSULTANT shall not absolve contractor of his responsibility/liability in relation to all HSE requirements.

3.1.9 Audit

Non-Conformances on HSE by Contractor (including his sub-contractors) as brought out during review/audit by his internal audit team as well as OWNER/Consultant's representative shall be resolved forthwith by Contractor. Compliance report shall be submitted to OWNER/CONSULTANT.

3.1.10 Meetings

The Contractor shall ensure participation of his top most executive at site (viz. Resident Engineer/Site-in-Charge) in Safety committee/HSE Committee meetings arranged by OWNER/CONSULTANT. The compliance of any observations during the meeting shall be arranged urgently. He shall assist OWNER/CONSULTANT to achieve the targets set by them on HSE during the project implementation.

3.1.11 The Contractor shall adhere consistently to all provisions of HSE requirements. In case of non-compliance or repeated failure in implementation of any of the HSE provisions; OWNER/CONSULTANT may impose stoppage of work without any cost & time implication to the

	STANDARD SPECIFICATION FOR HEALTH, SAFETY AND ENVIRONMENT (HSE) MANAGEMENT AT CONSTRUCTION SITES	DOCUMENT NO.	REV
		11-0269-01-18-02-037	0
		SHEET 3 OF 37	

Owner and/or impose a suitable penalty, up to a cumulative limit of 1.0% (one percent) of the contract value with a ceiling of Rs.10 lacs (Rupees Ten Lacs only). This penalty shall be in addition to all other penalties specified elsewhere in the contract. The decision of imposing stoppage work, its extent and penalty shall rest with OWNER/CONSULTANT. The same shall be binding on the Contractor. The penalty does not make the contractor eligible to continue the work in unsafe manner.

3.2 HOUSE KEEPING

3.2.1 Contractor shall ensure that a high degree of house keeping is maintained and shall ensure interalia; the following:

All surplus earth and debris are removed/disposed off from the working areas to identified location(s). Unused/surplus cables, steel items and steel scrap lying scattered at different places within the working areas are removed to identified location(s).

All wooden scrap, empty wooden cable drums and other combustible packing materials, shall be removed from work place to identified location(s).

Roads shall be kept clear and materials like pipes, steel, sand, boulders, concrete, chips and bricks etc. shall not be allowed on the roads to obstruct free movement of men & machines.

Fabricated steel structural, pipes & piping materials shall be stacked properly for erection. Water logging on roads shall not be allowed.

No parking of trucks/trolleys, cranes and trailers etc. shall be allowed on roads, which may obstruct the traffic movement.

Utmost care shall be taken to ensure over all cleanliness and proper upkeep of the working areas. Trucks carrying sand, earth and pulverized materials etc. shall be covered while moving within the plant area/or these materials shall be transported with top surface wet.

The contractor shall ensure that the atmosphere in plant area and on roads is free from particulate matter like dust, sand, etc. by keeping the top surface wet for ease in breathing. At least two exits for any unit area shall be assured at all times.

3.3 HSE MEASURES

3.3.1 Construction Hazards

Contractor shall ensure that during the performance of the work, all hazards have been identified, assessed and eliminated.

A list of construction hazards along with their effects & preventive measures is given in the Annexure-V.

3.3.2 Accessibility

The Contractor shall provide safe means of access to any working place including provisions of suitable and sufficient scaffolding at various stages during all operations of the work for the safety of his workmen and OWNER/CONSULTANT.

3.3.3 Personal Protective Equipments (PPEs)

The contractor shall ensure that all their staff and workers including their sub-contractor(s)'s have been issued & wear appropriate PPEs like safety helmets, safety shoes, safety belt, full body harness, protective goggles, gloves etc. All these gadgets shall conform to applicable IS Specifications/CE or other applicable international standards.

For shot blasting, the usage of protective helmets (approved by the competent authority), gauntlet and protective clothing is mandatory.

For offshore contracts, contractor shall provide PPEs (new) to CONSULTANT & Owner's personnel at his (contractor's) cost. All personnel shall wear life jacket at all time.

3.3.4 Working at height

	STANDARD SPECIFICATION FOR HEALTH, SAFETY AND ENVIRONMENT (HSE) MANAGEMENT AT CONSTRUCTION SITES	DOCUMENT NO.	REV
		11-0269-01-18-02-037	0
		SHEET 4 OF 37	

The contractor shall issue height permit for working above 3 meters height after verifying and certifying the checkpoints as specified in the attached permit. He shall also undertake to ensure compliance to the conditions of the permit during the currency of the permit including adherence to personal protective equipments.

The permit shall be issued initially for one week or expected duration of an activity and extended further for the balance duration. This permit shall be applicable in areas where specific clearance from Owner's operation Department/Safety Department is not applicable. CONSULTANT field Engineers/Safety Officers/Area Coordinators may verify and sign this permit during the execution of the job.

In case work is undertaken without taking sufficient precautions as given in the permit, CONSULTANT Engineers may cancel the permit and stop the work till satisfactory compliance is arranged. Contractors are expected to maintain a register for issuance of permit and extensions thereof including preserving the used permits for verification during audits etc.

Contractor shall arrange (at his cost) and ensure use of Fall Arrester Systems by his workers. Fall arresters are to be used while climbing tall structures. These arresters should lock automatically against the anchorage line, restricting free fall of the user. The device is to be provided with a double security opening system to ensure safe attachment or release of the user at any point of rope. In order to avoid shock, the system should be capable of keeping the person in vertical position in case of a fall.

Contractor shall ensure that Life Lines are used by all personnel while working at height. One end of the life line shall be firmly tied with the worker and the other end with a fixed and rigid structure. The life line should be strong enough to take the load of the worker in case of a fall.

Contractor shall provide Roof Top Walk ladders for carrying out activities on sloping roofs in order to reduce the chances of slippages.

Contractor shall ensure that a proper Safety Net System is used wherever the hazard of fall from height is present. The safety net shall be located not more than 9.0 meters below the working surface extending on either side up to sufficient margin to arrest or to reduce the consequences of a possible fall of persons working at different heights.

3.3.5 Electrical installations

The contractor shall ensure that electrical systems and equipment including tools and tackles are properly selected, installed, used and maintained.

The contractor shall deploy qualified and licensed electricians for proper and safe installation and for regular inspection of construction power distribution lines/points including their earthing. A copy of the license shall be submitted to CONSULTANT for records.

3.3.6 Welding/Gas cutting

Contractor shall ensure that flash back arresters conforming to BS: 6158 or equivalent are installed on all gas cylinders while in use. All cylinders shall be mounted on trolleys. All welding machines shall have effective earthing. To eliminate radiation hazard, Tungsten electrodes used for Gas Tungsten Arc Welding shall not contain Thorium.

3.3.7 Ergonomics and tools & tackles

The Contractor shall assign to his workmen, tasks commensurate with their qualification, experience and state of health. All lifting tools, tackles, equipment, accessories including cranes shall be tested periodically by statutory/competent authority for their condition and load carrying capacity. Valid test and fitness certificates from the authority shall be submitted to Owner/CONSULTANT for their review/acceptance before the lifting tools, tackles, equipment, accessories and cranes are used.

	STANDARD SPECIFICATION FOR HEALTH, SAFETY AND ENVIRONMENT (HSE) MANAGEMENT AT CONSTRUCTION SITES	DOCUMENT NO.	REV
		11-0269-01-18-02-037	0
		SHEET 5 OF 37	

Contractor shall ensure installation of Safe Load Indicator (SLI) on all cranes (while in use) to minimize overload risk. SLI shall have capability to continuously monitor and display the load on the hook, and automatically compare it with the rated crane capacity at the operating condition of the crane. The system shall also provide visual and audible warnings at set capacity levels to alert the operator in case of violations.

3.3.8 Occupational Health

The contractor shall identify all operations that can adversely affect the health of its workers and issue and implement mitigation measures. For surface cleaning operations, sand blasting shall not be permitted even if not explicitly stated elsewhere in the contract.

3.3.9 Hazardous substances

Hazardous and/or toxic materials such as solvent coating or thinners shall be stored in appropriate containers, which shall be labeled with the name of the materials, the hazards associated with its use and necessary precautions to be taken.

Where contact or exposure of hazardous materials/Noise pollution exceeds the specified limit or otherwise have harmful affects, appropriate personal protective equipments such as gloves, earmuffs, goggles, aprons, chemical resistant clothing, respirator, etc. shall be used.

3.3.10 Spills

Chemical and other spills shall be contained and cleaned up immediately to prevent further contamination.

3.3.11 Radiation exposure

- a) All personnel exposed to physical agents such as non-ionizing radiation, ultraviolet rays or similar other physical agents shall be provided with adequate shielding or protection commensurate with the type of exposure involved.
- b) For ionizing radiation, requirements of Bhabha Atomic Research Centre (BARC) shall be followed.

3.3.12 Road Safety

The contractor shall ensure adequately planned road transport safety management system. The vehicles shall be fitted with reverse warning alarms. The contractor shall also ensure a separate pedestrian route for safety of the workers and comply with all traffic rules and regulations.

For pipeline jobs, the contractor shall submit a comprehensive plan covering transportation of pipes, movement of side booms, movement of vehicles on the ROW, etc.

3.3.13 Welfare measures

Contractor shall at the minimum, ensure the following facilities at work sites :

A crèche where 10 or more female workers are having children below the age of 6 years.

Reasonable canteen facilities at appropriate location depending upon site conditions.

Rest rooms (separate for male workers and female workers)

Toilets, drinking water, adequate lighting at site and labour camps, commensurate with applicable Laws/Legislation.

3.3.14 Environment Protection

	STANDARD SPECIFICATION FOR HEALTH, SAFETY AND ENVIRONMENT (HSE) MANAGEMENT AT CONSTRUCTION SITES	DOCUMENT NO.	REV
		11-0269-01-18-02-037	0
		SHEET 6 OF 37	

Contractor shall ensure proper storage and utilization methodology of materials that are detrimental to the environment. Where required, contractor shall ensure that only the environment friendly materials are selected and emphasize on recycling of waste materials such as metals, plastics, glass, paper, oil and solvents.

For pipeline jobs, top soil shall be stacked separately while making ROW through fields. This fertile soil shall be placed back on top after backfilling.

3.3.15 Rules & Regulations

All persons deployed at site shall be knowledgeable of and comply with the environmental laws, rules and regulations relating to the hazardous materials, substances and wastes. Contractor shall not dump, release or otherwise discharge or dispose off any such materials without the express authorization of OWNER/CONSULTANT.

3.4 TOOL BOX MEETING (TBM)

Contractor shall conduct daily TBM with workers prior to start of work and shall maintain proper record of the meeting. A suggested format is given below. The TBM is to be conducted by the immediate supervisor of the workers.

TOOL BOX MEETING RECORDING SHEET		
Date & Time		
Subject		
Presenter		
Hazards Involved		
Precautions to be taken		
Worker's Name	Signature	Section
Remarks, if any		

The topics during TBM shall include:

- Hazards related to work assigned on that day and precautions to be taken.
- Any forthcoming HSE hazards/events/instruction/orders, etc.

The above record can be kept in local language, which workers can read. These records shall be made available to OWNER/CONSULTANT whenever demanded.

3.5 TRAINING

Contractor shall ensure that all his personnel possess appropriate training to carryout the assigned job safely. The training should be imparted in a language understood by them and should specifically be trained about.

- Potential hazards to which they may be exposed at their workplace
- Measures available for prevention, recurrence and elimination of these hazards

The topics during training shall cover, at the minimum:

- Education about hazardous jobs and precautions required
- Emergency and evacuation plan
- HSE requirements
- Fire fighting and First-Aid
- Use of PPEs

	STANDARD SPECIFICATION FOR HEALTH, SAFETY AND ENVIRONMENT (HSE) MANAGEMENT AT CONSTRUCTION SITES	DOCUMENT NO.	REV
		11-0269-01-18-02-037	0
		SHEET 7 OF 37	

Records of the training shall be kept and submitted to OWNER/CONSULTANT whenever demanded.

For off-shore and jetty jobs, contractor shall ensure that all personnel deployed have undergone structured training on swimming, use of lifeboats, basket landing, etc.

3.6 INSPECTION/AUDIT

The contractor shall carry out daily HSE inspection and record observations at a central location. These inspection records shall be freely accessible to Owner/CONSULTANT representatives. He shall also carry out internal HSE audits as well as cooperate during HSE audits by Owner/CONSULTANT, which will be at least two times during the project execution period.

4.0 DETAILS OF HSE MANAGEMENT SYSTEM BY CONTRACTOR

4.1 ON AWARD OF CONTRACT

The Contractor shall submit a comprehensive Health, Safety and Environment manual or procedure and HSE Plans for approval by OWNER/CONSULTANT prior to start of work. The Contractor shall participate in the pre-start meeting with OWNER/CONSULTANT to finalize HSE Plans including the following:

Job procedure to be followed by Contractor for activities covering handling of equipments, scaffolding, electric installations, etc. describing the risks involved, actions to be taken and methodology for monitoring each activity.

OWNER/CONSULTANT review/audit requirement.

Organization structure along with responsibility and authority, records/reports etc. on HSE activities.

Procedures for reporting and investigation of accidents and near misses

HSE Training programmes.

Reference to Rules, Regulations and Statutory requirements.

HSE reports.

4.2 DURING JOB EXECUTION

4.2.1 Contractor shall implement approved Health, Safety and Environment management procedure/plan/manual including but not limited to as brought out under para 3.0. Contractor shall also ensure :

to arrange workmen compensation insurance, registration under ESI Act, third party liability insurance etc., as applicable

to arrange all HSE permits before start of activities (as applicable), like permits for hot work, confined space, working at heights, storage of chemical/explosive materials and its use and implement all precautions mentioned therein. In this regard, requirements of Oil industry Safety Directorate Standard No. Std-105 "Work Permit Systems" shall be complied with while working in existing plants.

to submit, timely, the completed checklist on HSE activities Monthly HSE report, accident reports, investigation reports etc. as per OWNER/CONSULTANT requirements. Compliance of instructions on HSE shall be done by Contractor and informed urgently to OWNER/CONSULTANT.

That his top most executive at site attends all the Safety Committee/HSE meetings arranged by OWNER/CONSULTANT. Only in case of his absence from site that a second senior most person shall be nominated by him, in advance, and communicated to OWNER/CONSULTANT.

Display at site office and work locations caution boards, list of hospitals, emergency services available, etc.

Provide posters, banners for safe working to promote safety consciousness.

Assess, analyze and mitigate the construction hazards.

	STANDARD SPECIFICATION FOR HEALTH, SAFETY AND ENVIRONMENT (HSE) MANAGEMENT AT CONSTRUCTION SITES	DOCUMENT NO.	REV
		11-0269-01-18-02-037	0
		SHEET 8 OF 37	

Carryout audits/inspection at his works as well as sub-contractor works as per approved HSE document and submit the reports for OWNER/CONSULTANT review.
 Assistance and cooperation during HSE audits by OWNER/CONSULTANT, and submit compliance report.
 Generation and submission of HSE records/report as per HSE Plan. And this specification.
 Apprise OWNER/CONSULTANT on HSE activities at site.
 Carryout all dismantling activities safely, with prior approval of OWNER/CONSULTANT representative.

5.0 RECORDS

The contractor shall maintain/submit HSE records in the following reporting formats:

1. Monthly HSE checklist cum compliance report: Accident/Fire report
 Supplementary Accident & Investigation report
2. Monthly HSE report
3. Permit for working above 3 mete height
4. HSE Plan

IS – CODES FOR HSE

SP:53	Safety code for the use, Care and protection of hand operated tools.
IS: 816	Code of practice for safety and health requirements in electric and gas welding and cutting operations
IS: 1179	Eye and Face precautions during welding, equipment etc.
IS: 1860	Safety requirements for use, care and protection of abrasive grinding wheels.
IS: 1989(Part-I & II)	Leather safety boots and shoes
IS: 2925	Industrial Safety Helmets
IS: 3016	Code of practice for fire safety precautions in welding and cutting operations.
IS: 3043	Code of practice for earthing.
IS: 3521	Industrial Safety belts and harness.
IS: 3738	Rubber boots.
IS: 3996	Safety Code of scaffolds and ladders.
IS: 4770	Rubber gloves for electrical purposes
IS: 5216 (Part-I)	Recommendations on Safety procedures and practices in electrical works
IS: 5557	Industrial and Safety rubber lined boots.
IS: 5983	Eye protectors
IS:6519	Selection, care and repair of Safety footwear
IS: 6994 (Part-I)	Industrial Safety Gloves (Leather & Cotton Gloves)
IS: 7293	Safety Code for working with construction Machinery
IS: 9167	Ear protectors
IS: 11006	Flash back arrestor (Flame arrestor)
IS:11016	General and safety requirements for machine tools and their operation
IS: 11226	Leather safety footwear having direct moulded rubber sole
IS: 11972	Code of practice for safety precaution to be taken when entering a sewerage system
IS: 13367	Code of practice-safe use of cranes
IS: 13416	Recommendations for preventive measures against hazards at working place

	STANDARD SPECIFICATION FOR HEALTH, SAFETY AND ENVIRONMENT (HSE) MANAGEMENT AT CONSTRUCTION SITES	DOCUMENT NO.	REV
		11-0269-01-18-02-037	0
		SHEET 9 OF 37	

ANNEXURE - II

DETAILS OF FIRST AID BOX

SL.NO	DESCRIPTION	QUANTITY
1.	Small size Roller Bandages, 1 inch wide (Finger Dressing small)	6 Pcs.
2.	Medium size Roller Bandages, 2 inch wide (Hand and Foot Dressing)	6 Pcs.
3.	Large size Roller Bandages, 4 inch wide (Body Dressing Large)	6 Pcs.
4.	Large size Burn Dressing (Bun Dressing Large)	4 Pkts.
5.	Cotton wool (20 gms packing)	4 Pkts.
6.	Antiseptic Solution Dettol (100 ml.) or Savalon	1 Bottle
7.	Mercurochrome Solution (100 ml.) 2% in water	1 Bottle
8.	Sal-volatile (20 ml. Ammonia)	1 Bottle
9.	A Pair of Scissors	1 Piece
10.	Adhesive Plaster (1.25 cm x 5 m)	1Spool
11.	Eye pads in Separate Sealed Packet	4 Pcs.
12.	Tourniquet	1 No.
13.	Safety Pins	1 Dozen
14.	Tine IODINE (100 ml.)	1 Bottles
15.	Ointment for burns (Burnol 20 gms.)	1 Bottole
16.	Polythene Wash cup for washing eyes	1 No.
17.	Potassium Permanganate (20 gms.)	1 Pkt.
18.	Tinc. Benzoine (100 ml.)	1 Bottole
19.	Triangular Bandages	2 Nos.
20.	Band Aid Dressing	5 Pcs.
21.	Iodex (25 gms.)	1 Bottole
22.	Tongue Depressor	1 No.
23.	Boric Acid Powder (20 gms.)	2 Pkt.
24.	Sodium Bicarbonate (20 gms.)	1 Pkt.
25.	Dressing Powder (Nebasulf) (10 gms.)	1 Bottole
26.	Medicinal Glass	1 No.
27.	Duster	1 No.
28.	Booklet (English & Local Language)	1 No. each
29.	Soap	1 No.
30.	Toothache Solution	1 No.
31.	Eye Ointment	1 Bottle
32.	Vicks (22 gms.)	1 Bottle
33.	Forceps	1 No.
34.	Cottom Buds (5 nos.)	1 Pkt.
35.	Note Book	1 No.
36.	Splints	4 Nos.
37.	Lock	1 Piece
38.	Life Saving/Emergency/Over-the Counter Drugs	As decided at site
	NOTE : Type of Box Size	Aluminum 14" x 12" x 4"

	STANDARD SPECIFICATION FOR HEALTH, SAFETY AND ENVIRONMENT (HSE) MANAGEMENT AT CONSTRUCTION SITES	DOCUMENT NO.	REV
		11-0269-01-18-02-037	0
		SHEET 10 OF 37	

Annexure-III

TYPES OF FIRE EXTINGUISHERS AND THEIR APPLICATION

	CARBON DIOXIDE	DRY CHEMICAL				WATER TYPE				FOAM
		SODIUM POTASSIUM BICARBONATE		MULTI PURPOSE A B C		STORED PRESSURE	CARTRIDGE OPERATED	WATER PUMP TANK	SODIUM ACID	
	CO2	CARTRIDGE OPERATED	STORED PRESSURE	STORED PRESSURE	CARTRIDGE OPERATED					
CLASS A FIRES WOOD PAPER TRASH HAVING GLOWING EMBERS	x	x	x	/	/	/	/	/	/	/
(BUT CAN CONTROL MINOR SURFACE FIRES)										
CLASS B FIRES FLAMMABLE LIQUIDS GASOLINE OIL PAINT GRASE ETC.	/	/	/	/	/	x	x	x	x	/
CLASS C FIRES ELECTRICAL EQUIPMENT	/	/	/	/	/	x	x	x	x	x

LEGEND : / : CAN BE USED
 X : NOT TO BE USED

	STANDARD SPECIFICATION FOR HEALTH, SAFETY AND ENVIRONMENT (HSE) MANAGEMENT AT CONSTRUCTION SITES	DOCUMENT NO.	REV
		11-0269-01-18-02-037	0
		SHEET 11 OF 37	

ANNEXURE-IV

INDICATIVE LIST OF STATUTORY ACTS & RULES

Indian Explosives Act, 1984
The Motor Vehicles Act, 1988
The Factories Act, 1949
The Petroleum Act, 2002
Workmen Compensation 'act
Static/Mobile Pressure Vessel Act
Indian Electricity Act
Indian Boiler Act, 1923
Water (Prevention & Control Pollution) Act, 1974
Water (Prevention & Control of Pollution) Cess Act-1977
The Mines & Minerals (Regulation & Development) Act-1947
The Air (Prevention & control of Pollution) Act-1981 The
Atomic Energy Act-1962
The Radiation Protection Rules-1971
The Indian Fisheries Act-1954
The Indian Forest Act-1927
The Wild Life (Protection) Act-1972
The Environment (Protection) Act-1986
The Environment (Protection) Rules-1986
The Hazardous Wastes (Management & Handling) Rules-1989
The Manufacture, Storage & Import of Hazardous Chemicals Rules-
1989 The Central Motor Vehicles Rules-1989
The Building and Other Construction Workers (Regulation of Employment and Condition of Service) Act,
1996

	STANDARD SPECIFICATION FOR HEALTH, SAFETY AND ENVIRONMENT (HSE) MANAGEMENT AT CONSTRUCTION SITES	DOCUMENT NO.	REV
		11-0269-01-18-02-037	0
		SHEET 12 OF 37	

ANNEXURE-V

CONSTRUCTION HAZARDS, THEIR EFFECTS & PREVENTIVE MEASURES

ACTIVITY	TYPE OF HAZARD	EFFECT OF HAZARD	PREVENTIVE MEASURES
(A) EXCAVATION • Pit Excavation up to 3.0m	$\frac{3}{4}$ Falling into pit	$\frac{3}{4}$ Personal injury	$\frac{3}{4}$ Provide guard rails/barricade with warning signal. $\frac{3}{4}$ Provide at least two entries/exits. $\frac{3}{4}$ Provide escape ladders.
	$\frac{3}{4}$ Earth Collapse	$\frac{3}{4}$ Suffocation/ Breathlessness $\frac{3}{4}$ Buried	$\frac{3}{4}$ Provide suitable size of shoring and strutting, if required. $\frac{3}{4}$ Keep soil heaps away from the edge equivalent to 1.5m or depth of pit whichever is more. $\frac{3}{4}$ Don't allow vehicles to operate too close to excavated areas. Maintain at least 2m distance from edge of cut. $\frac{3}{4}$ Maintain sufficient angle of repose. Provide slope not less than 1:1 and suitable bench of 0.5m width at every 1.5m depth of excavation in all soils except hard rock. $\frac{3}{4}$ Battering/benching the sides.
	$\frac{3}{4}$ Contact with buried electric cables $\frac{3}{4}$ Gas/Oil Pipelines	$\frac{3}{4}$ Electrocut ion $\frac{3}{4}$ Explosion	$\frac{3}{4}$ Obtain permission from competent authorities, prior to excavation, if required. $\frac{3}{4}$ Locate the position of buried utilities by referring to plant drawings. $\frac{3}{4}$ Start digging manually to locate the exact position of buried utilities and thereafter use mechanical means.
• Pit Excavation beyond 3.0m	$\frac{3}{4}$ Same as above plus $\frac{3}{4}$ Flooding due to excessive rain/underground	$\frac{3}{4}$ Can cause drowning situation	$\frac{3}{4}$ Prevent ingress of water $\frac{3}{4}$ Provide ring buoys $\frac{3}{4}$ Identify and provide suitable size dewatering pump or well point system
	$\frac{3}{4}$ Digging in the vicinity of existing Building/Structure	$\frac{3}{4}$ Building/Structure may collapse $\frac{3}{4}$ Loss of health & wealth	$\frac{3}{4}$ Obtain prior approval of excavation method from local authorities $\frac{3}{4}$ Use under-piping method $\frac{3}{4}$ Construct retaining wall side by side

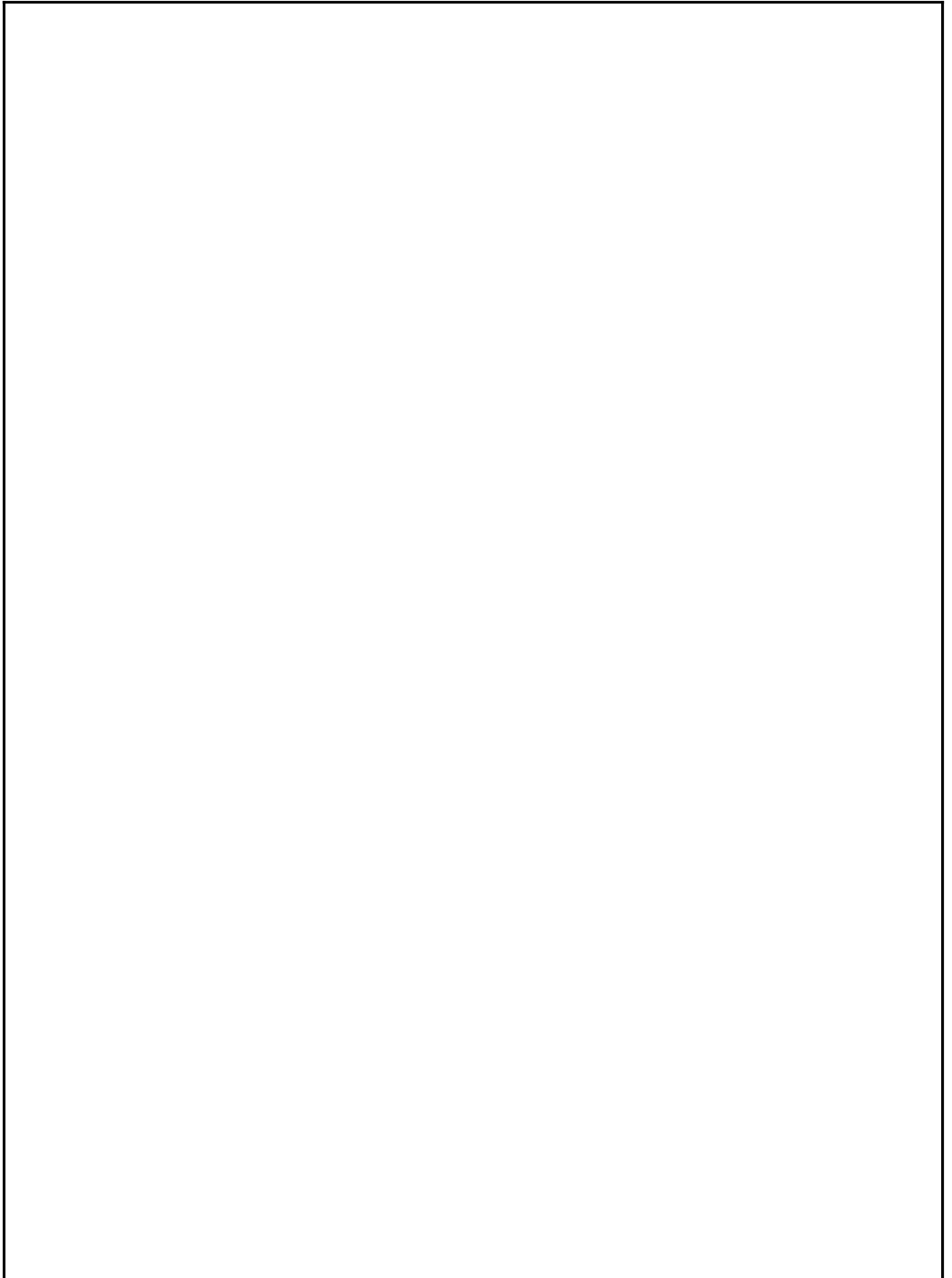

ACTIVITY	TYPE OF HAZARD	EFFECT OF HAZARD	PREVENTIVE MEASURES
	<ul style="list-style-type: none"> ¾ Movement of vehicles/equipments close to the edge of cut. 	<ul style="list-style-type: none"> ¾ May cause cave-in or slides ¾ Persons may get buried 	<ul style="list-style-type: none"> ¾ Barricade the excavated area with proper lighting arrangements ¾ Maintain at least distance from edge of cut ¾ Strengthen shoring strutting
<ul style="list-style-type: none"> • Narrow deep excavations for pipelines, etc. 	<ul style="list-style-type: none"> ¾ Same as above plus ¾ Frequent cave-in or slides 	<ul style="list-style-type: none"> ¾ May cause severe injuries or prove fatal 	<ul style="list-style-type: none"> ¾ Battering/benching of sides ¾ Provide escape ladders
	<ul style="list-style-type: none"> ¾ Flooding due to Hydro testing 	<ul style="list-style-type: none"> ¾ May arise drowning situation 	<ul style="list-style-type: none"> ¾ Same as above plus ¾ Bail out accumulated water ¾ Maintain adequate ventilation
<ul style="list-style-type: none"> • Rock excavation by blasting 	<ul style="list-style-type: none"> ¾ Improper handling of explosives 	<ul style="list-style-type: none"> ¾ May prove fatal 	<ul style="list-style-type: none"> ¾ Ensure proper storage, handling & carrying explosives by trained personnel. ¾ Comply with the applicable explosive acts & rules.
	<ul style="list-style-type: none"> ¾ Uncontrolled explosion 	<ul style="list-style-type: none"> ¾ May cause severe injuries or prove fatal 	<ul style="list-style-type: none"> ¾ Allow only authorized persons to perform blasting operations. ¾ Smoking and open flames are to be strictly prohibited.
	<ul style="list-style-type: none"> ¾ Scattering of stone pieces in atmosphere 	<ul style="list-style-type: none"> ¾ Can hurt people 	<ul style="list-style-type: none"> ¾ Use PPE like goggles, face mask, helmets etc.
<ul style="list-style-type: none"> • Rock excavating by blasting (Contd) 	<ul style="list-style-type: none"> ¾ Entrapping of persons/animals. 	<ul style="list-style-type: none"> ¾ May cause severe injuries or prove fatal 	<ul style="list-style-type: none"> ¾ Barricade the area with red flags and blow siren before blasting.
	<ul style="list-style-type: none"> ¾ Misfire 	<ul style="list-style-type: none"> ¾ May explode suddenly 	<ul style="list-style-type: none"> ¾ Do not return to site for at least 20 minutes or unless announced safe by designated person.
<ul style="list-style-type: none"> • Piling Work 	<ul style="list-style-type: none"> ¾ Failure of pile-driving equipment 	<ul style="list-style-type: none"> ¾ Can hurt people 	<ul style="list-style-type: none"> ¾ Inspect Piling rigs and pulley blocks before beginning of each shift.
	<ul style="list-style-type: none"> ¾ Noise pollution 	<ul style="list-style-type: none"> ¾ Can cause deafness and psychological imbalance. 	<ul style="list-style-type: none"> ¾ Use personal protective equipments like ear plugs, muffs, etc.
	<ul style="list-style-type: none"> ¾ Extruding rods/casing 	<ul style="list-style-type: none"> ¾ Can hurt people 	<ul style="list-style-type: none"> ¾ Barricade the area ¾ install sign boards ¾ Provide first-aid
	<ul style="list-style-type: none"> ¾ Working 	<ul style="list-style-type: none"> ¾ Can 	<ul style="list-style-type: none"> ¾ Keep sufficient distance

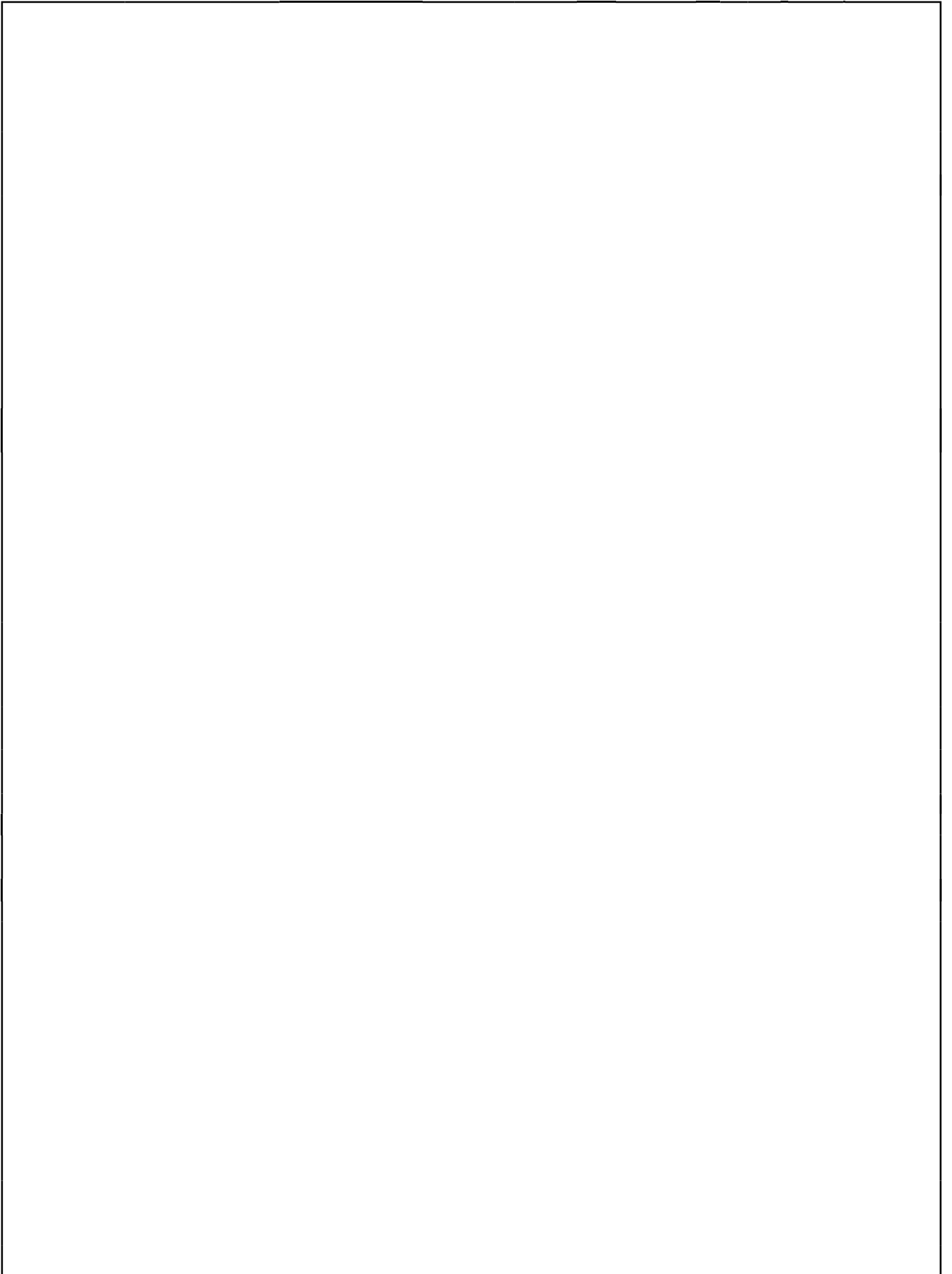

ACTIVITY	TYPE OF HAZARD	EFFECT OF HAZARD	PREVENTIVE MEASURES
	Working in the vicinity of 'Live-Electricity'	cause electrocution/ asphyxiation	from Live-Electricity as per IS code. $\frac{3}{4}$ Shut off the supply, if possible $\frac{3}{4}$ Provide artificial/rescue breathing to be injured.
(B) CONCRETING	$\frac{3}{4}$ Air pollution by cement	$\frac{3}{4}$ May affect Respiratory System	$\frac{3}{4}$ Wear respirators or cover mouth and nose with wet cloth.
	$\frac{3}{4}$ Handling of ingredients	$\frac{3}{4}$ Hands may get injured	$\frac{3}{4}$ Use gloves and other PPE.
	$\frac{3}{4}$ Protruding reinforcement rods.	$\frac{3}{4}$ Feet may get injured	$\frac{3}{4}$ Use Safety shoes. $\frac{3}{4}$ Provide platform above reinforcement for movement of workers.
	$\frac{3}{4}$ Earthing of electrical mixers, vibrators, etc. not done	$\frac{3}{4}$ Can cause electrocution/ asphyxiation	$\frac{3}{4}$ Ensure earthing of equipments and proper functioning of electrical circuit before commencement of work.
	$\frac{3}{4}$ Falling of materials from height	$\frac{3}{4}$ Persons may get injured	$\frac{3}{4}$ Use hard hats $\frac{3}{4}$ Remove surplus material immediately from work place $\frac{3}{4}$ Ensure lighting arrangements during night hours.
	$\frac{3}{4}$ Continuous pouring by same gang	$\frac{3}{4}$ Cause tiredness of workers and may lead to accident.	$\frac{3}{4}$ Insist on shift pattern $\frac{3}{4}$ Provide adequate rest to workers between subsequent pours.
	$\frac{3}{4}$ Revolving or concrete mixer/ vibrators	$\frac{3}{4}$ Parts of body or clothes may get entrapped.	$\frac{3}{4}$ Allow only mixers with hopper $\frac{3}{4}$ Provide safety cages around moving motors $\frac{3}{4}$ Ensure proper mechanical locking of vibrator
• Super-structure	$\frac{3}{4}$ Same as above plus $\frac{3}{4}$ Deflection in props or shuttering material	$\frac{3}{4}$ Shuttering /props may collapse and prove fatal	$\frac{3}{4}$ Avoid excessive stacking on shuttering material $\frac{3}{4}$ Check the design and strength of shuttering material before commencement of work $\frac{3}{4}$ Rectify immediately the deflection noted during concreting
	$\frac{3}{4}$ Passage to work place	$\frac{3}{4}$ Improperly tied and designed props/planks may collapse	$\frac{3}{4}$ Ensure the stability and strength of passage before commencement of work $\frac{3}{4}$ Do not overload and stand under the passage
(C) REINFORCEMENT	$\frac{3}{4}$ Curtailment and	$\frac{3}{4}$ Persons may get	$\frac{3}{4}$ Use PPE like gloves, shoes, helmets, etc.

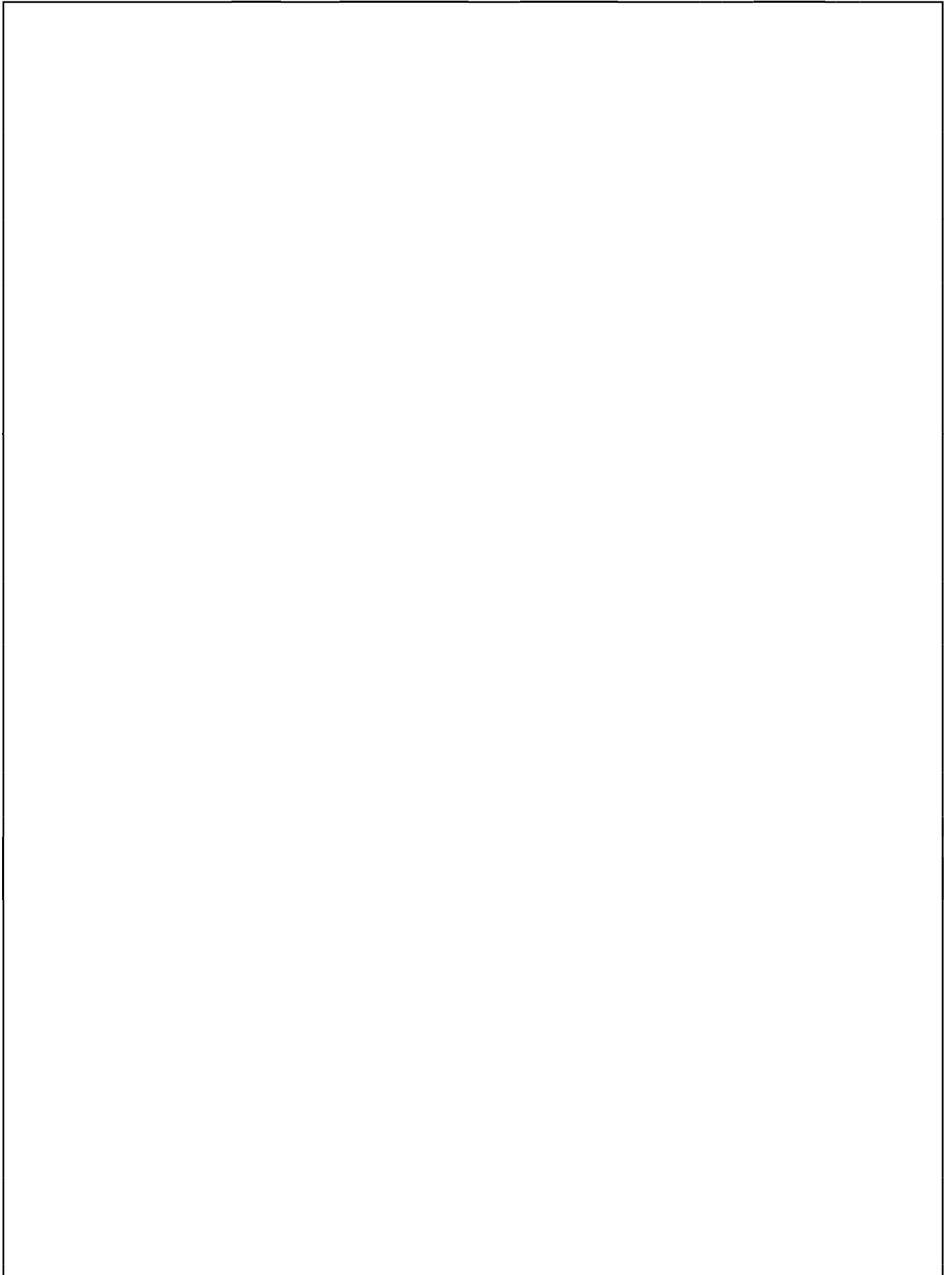

ACTIVITY	TYPE OF HAZARD	EFFECT OF HAZARD	PREVENTIVE MEASURES
T	binding of rods	injured	¾ Avoid usage of shift tools
	¾ Carrying of rods for short distance/at heights	¾ Workers may get injured their hands and shoulders.	¾ Provide suitable pads on shoulders and use safety gloves ¾ Tie up rods in easily liftable bundles ¾ Ensure proper staging.
	¾ Checking of clear distance/cover with hands	¾ Rods may cut or injure the finger	¾ Use measuring devices like tape, measuring rods, etc.
	¾ Hitting projected rods and standing on cantilever rods	¾ Persons may get injured and fell down	¾ Use safety shoes and avoid standing unnecessarily on cantilever rods ¾ Avoid wearing of loose clothes
	¾ Falling of material from height	¾ May prove fatal	¾ Use helmets ¾ Provide safety nets
	¾ Transportation of rods by trucks	¾ Protruded rods may hit the persons	¾ Use red flags/lights at the ends ¾ Do not protrude the rods in front of or by the side of driver's cabin. ¾ Do not extend the rods 1/rd of deck length or 1.5 m which is less
(D) WELDING AND GAS CUTTING	¾ Welding radiates invisible ultraviolet and infrared rays	¾ Radiation can damage eyes and skin.	¾ Use specified shielding devices and other PPE of correct specifications ¾ Avoid throated tungsten electrodes for GTAW
	¾ Improper placement of oxygen and acetylene cylinders	¾ Explosion may occur	¾ Move out any leaking cylinder ¾ Keep cylinder in vertical position ¾ Use trolley for transportation of cylinders and chain them ¾ Use flash back arrestors
	¾ Leakage/cuts in hoses	¾ May cause fire	¾ Purge regulators immediately and then turn off ¾ Never use grease or oil on oxygen line connections and copper fittings on acetylene lines ¾ Inspect regularly gas carrying hoses

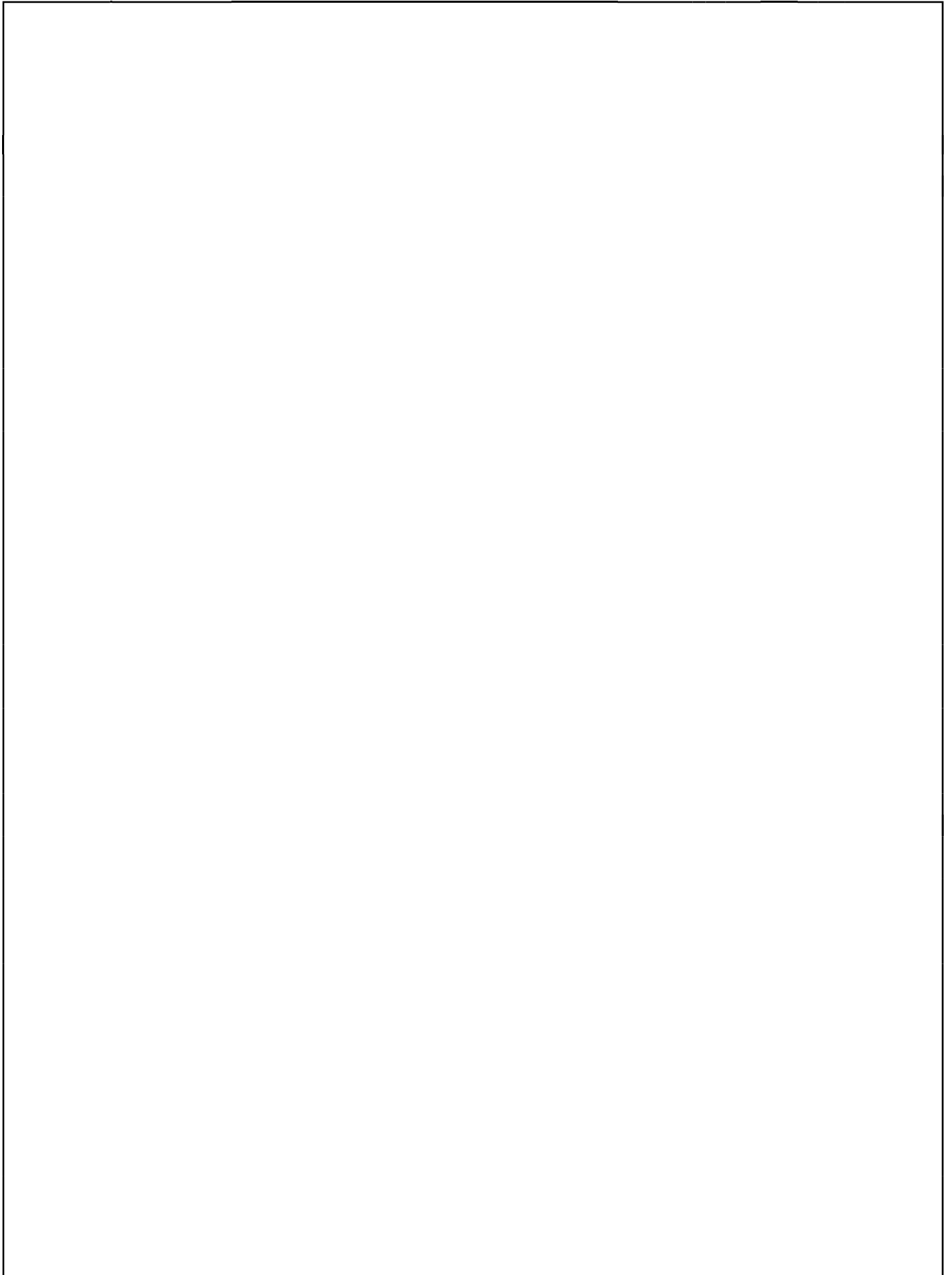

ACTIVITY	TYPE OF HAZARD	EFFECT OF HAZARD	PREVENTIVE MEASURES
			<ul style="list-style-type: none"> ¾ Use the current for which the cable is designed ¾ Always use red hose for acetylene and other fuel gases and black for oxygen
	¾ Opening of cylinder	¾ Cylinder may burst	<ul style="list-style-type: none"> ¾ Always stand back from the regulator while opening the cylinder ¾ Turn valve slowly to avoid bursting ¾ Cover the lug terminals to prevent short circuiting.
	¾ Welding of tanks, container or pipes storing flammable liquids	¾ Explosion may occur	<ul style="list-style-type: none"> ¾ Empty them before welding ¾ Never attach the ground cable to tanks, container or pipe storing flammable liquids ¾ Never use LPG for gas cutting
(E) RADIOGRAPHY	¾ Ionizing radiation	¾ Radiations may react with the skin and can cause cancer, skin irritation, dermatitis, etc.	<ul style="list-style-type: none"> ¾ Ensure safety regulations as per BARC before commencement of job. ¾ Cordon off the area and install Radiation warning symbols ¾ Restrict the entry of unauthorized persons ¾ Wear appropriate PPE and film badges issued by BARC
	¾ Transportation and Storage of Radiography source	¾ Same as above	<ul style="list-style-type: none"> ¾ Never touch or handle radiography source with hands ¾ Store radiography source inside a pit in an exclusive isolated storage room with lock and key arrangement. The pit should be approved by BARC ¾ Radiography source should never be carried either in passenger bus or in a passenger compartment of trains. ¾ BARC have to be informed before source movement. ¾ Permission from Director General of Civil Aviation is required for booking radio isotopes with airlines.
	¾ Loss of Radio isotope	¾ Same as above	<ul style="list-style-type: none"> ¾ Try to locate with the help of Survey Meter ¾ Inform BARC(*)
(F) ELECTRICAL INSTALLATION AND USAGE	¾ Short circuiting	¾ Can Cause Electrocutation or Fire	<ul style="list-style-type: none"> ¾ Use rubberized hand gloves and other PPE ¾ Don't lay wires under carpets, mats or door ways. ¾ Allow only licensed

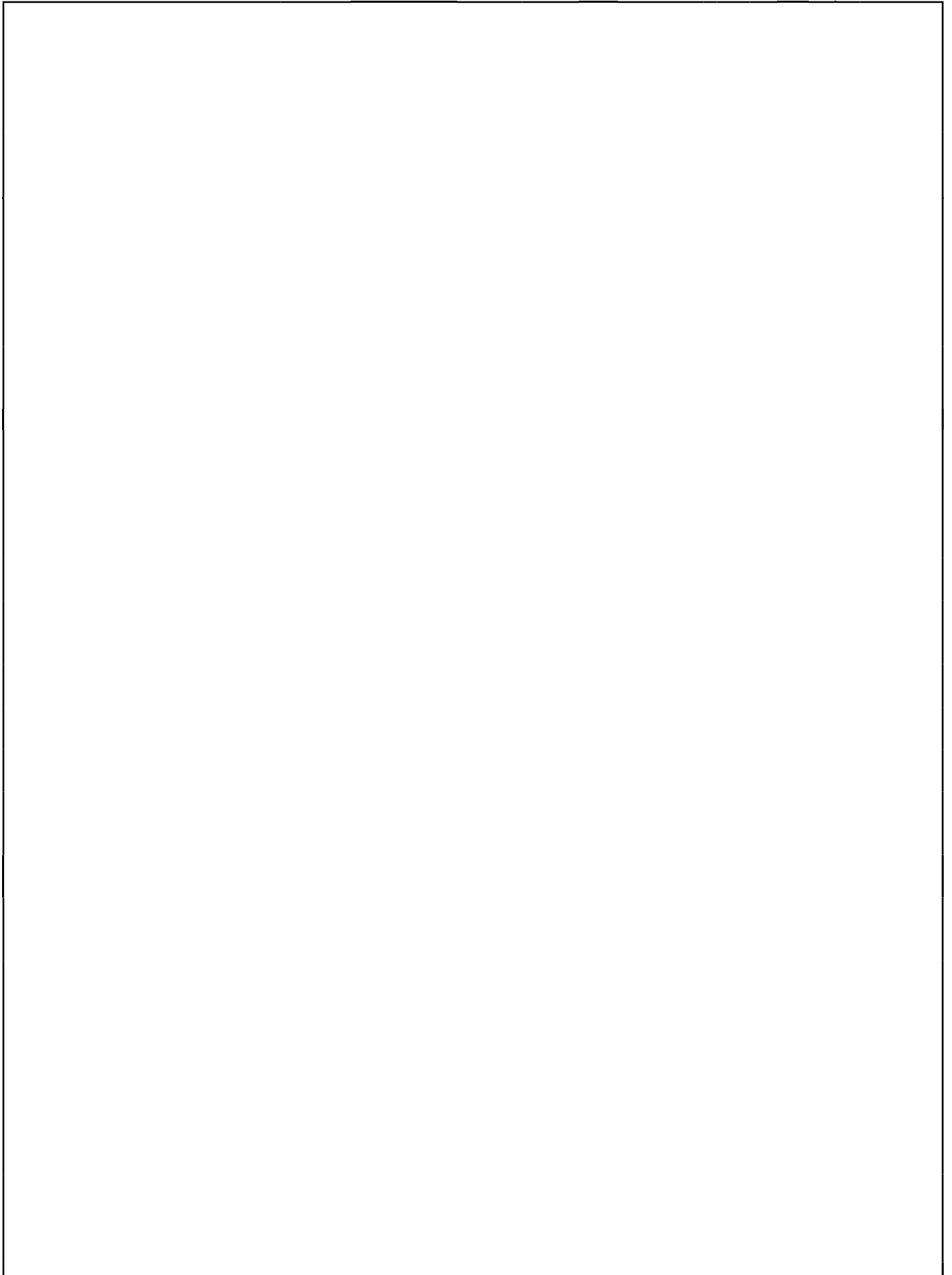

ACTIVITY	TYPE OF HAZARD	EFFECT OF HAZARD	PREVENTIVE MEASURES
			<p>electricians to perform on electrical facilities</p> <ul style="list-style-type: none"> ¾ Use one socket for one appliance ¾ Ensure usage of only fully insulated wires or cables ¾ Don't place bare wire ends in a socket ¾ Ensure earthing of machineries and equipments ¾ Do not use damaged cords and avoid temporary connections ¾ Use spark-proof/flame proof type field distribution boxes. ¾ Do not allow open/bare connections ¾ Provide all connections through ELCB ¾ Protect electrical cables/equipment's from water and naked flames ¾ Check all connections before energizing
	¾ Overloading of Electrical System	¾ Bursting of system can occur which leads to fire	<ul style="list-style-type: none"> ¾ Display voltage and current ratings prominently with 'Danger' signs. ¾ Ensure approved cable size, voltage grade and type ¾ Switch off the electrical utilities when not in use ¾ Do not allow an authorized connections ¾ Ensure proper grid wise distribution of Power.
	¾ Improper laying of overhead and underground transmission lines/cables	¾ Can cause electrocution and prove fatal	<ul style="list-style-type: none"> ¾ Do not lay unarmored cable directly on ground, wall, roof of trees ¾ Maintain at least 3m distance from HT cables ¾ All temporary cables should be laid at least 750 mm below ground on 100 mm fine sand overlying by brick soling ¾ Provide proper sleeves at crossings/intersections ¾ Provide cable route markers indicating the type and depth of cables at intervals not exceeding 30m and at the diversions/termination.
(G) FIRE PREVENTION	¾ Small fires can	¾ Cause burn injuries	¾ In case a fire breaks out, press fire alarm system and

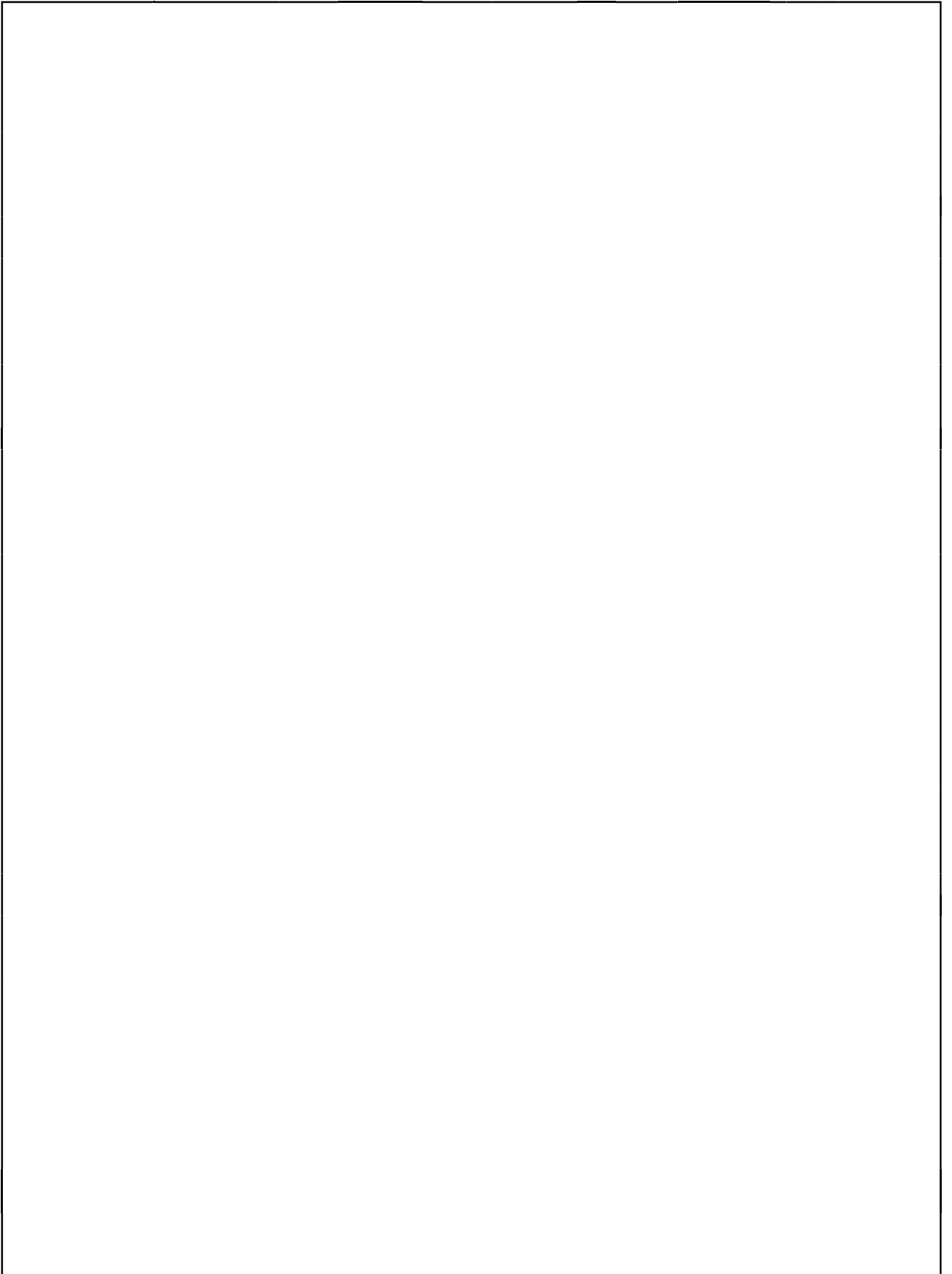

ACTIVITY	TYPE OF HAZARD	EFFECT OF HAZARD	PREVENTIVE MEASURES
AND PROTECTION	become big ones and may spread to the surrounding areas	and may prove fatal	shout "Fire, Fire" $\frac{3}{4}$ Keep buckets full of sand & water/fire extinguishing equipment near hazardous locations $\frac{3}{4}$ Confine smoking to 'Smoking Zones' only $\frac{3}{4}$ Train people for using specific type of fire equipments under different classes of fire $\frac{3}{4}$ Keep fire doors/ shutters, passages and exit doors unobstructed $\frac{3}{4}$ Maintain good house keeping and first-aid boxes (for detail refer Annex-2) $\frac{3}{4}$ Don't obstruct access to fire extinguishers $\frac{3}{4}$ Do not use elevators for evacuation during fire $\frac{3}{4}$ Maintain lightning arrestors for elevated structures
	$\frac{3}{4}$ Improper selection of Fire extinguishers	$\frac{3}{4}$ It may not extinguish the fire	$\frac{3}{4}$ Ensure usage of correct fire extinguisher meant for the specified fire (for details refer Annexure-III) $\frac{3}{4}$ Do not attempt to extinguish Oil and electric fires with water. Use foam cylinders/CO2/sand or earth.
	$\frac{3}{4}$ Improper storage of highly inflammable substances	$\frac{3}{4}$ Same as above	$\frac{3}{4}$ Maintain safe distance of flammable substances from source of ignition $\frac{3}{4}$ Restrict the distribution of flammable materials to only min. necessary amount $\frac{3}{4}$ Construct specifically designed fuel storage facilities $\frac{3}{4}$ Keep chemicals in cool and dry place away from heat. Ensure adequate ventilation $\frac{3}{4}$ Before welding operation, remove or shield the flammable material properly $\frac{3}{4}$ Store flammable materials in stable racks, correctly labeled $\frac{3}{4}$ Wipe off the spills immediately
	$\frac{3}{4}$ Short circuiting of electrical system	$\frac{3}{4}$ Same as above $\frac{3}{4}$ Can cause Electrocutation	$\frac{3}{4}$ Don't lay wires under carpets, mats or door ways $\frac{3}{4}$ Use one socket for one appliance $\frac{3}{4}$ Use only fully insulated

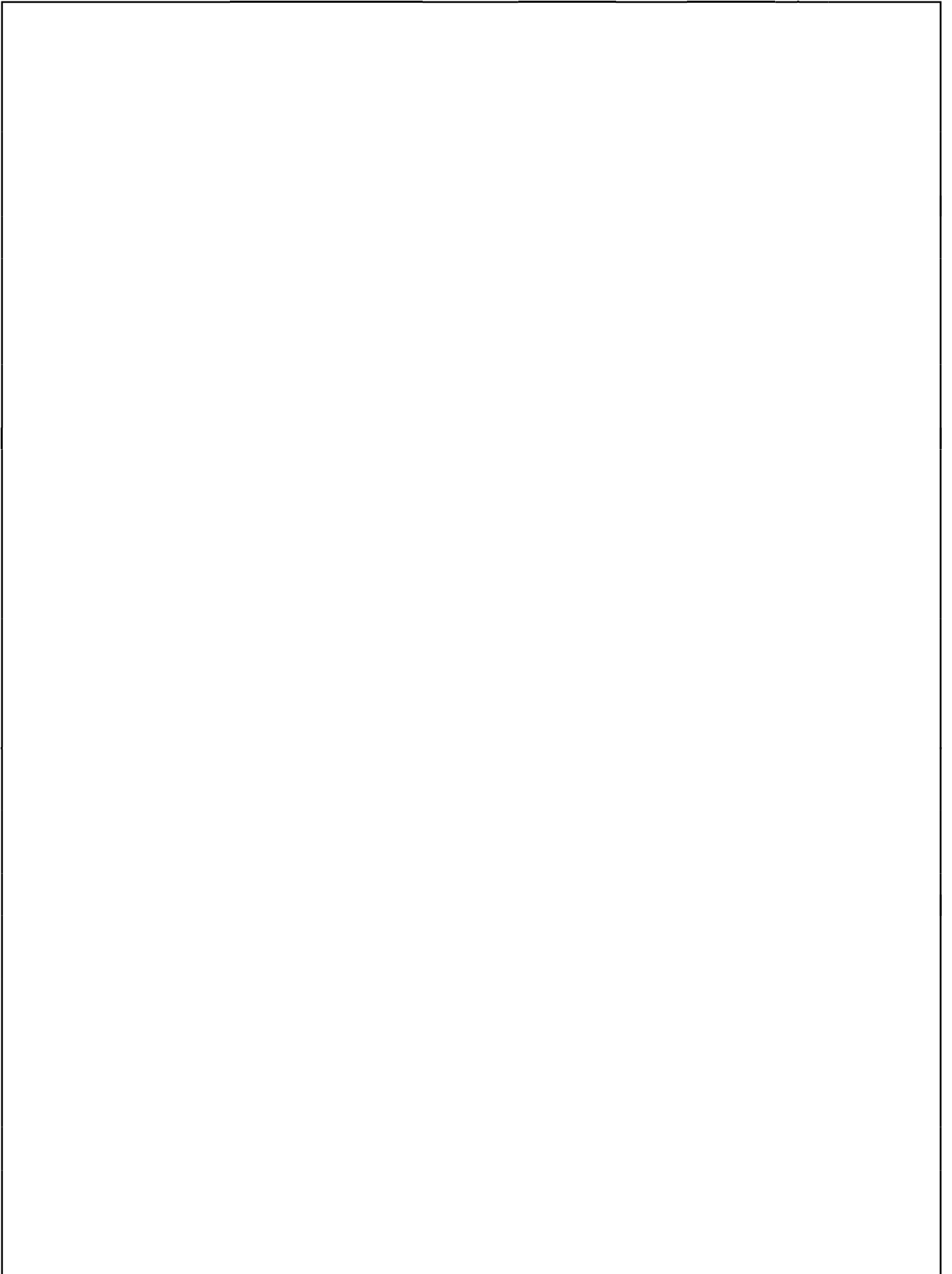

ACTIVITY	TYPE OF HAZARD	EFFECT OF HAZARD	PREVENTIVE MEASURES
			<p>wires or cables</p> <ul style="list-style-type: none"> ¾ Do not allow open/bare connections ¾ Provide all connections through ELCB ¾ Ensure earthing of machineries and equipments
(H) VEHICULAR MOVEMENT	<ul style="list-style-type: none"> ¾ Crossing the Speed Limits (Rash driving) 	<ul style="list-style-type: none"> ¾ Personal injury 	<ul style="list-style-type: none"> ¾ Obey speed limits and traffic rules strictly ¾ Always expect the unexpected and be a defensive drive ¾ Use seat belts/helmets ¾ Blow horn at intersections and during overtaking operations. ¾ Maintain the vehicle in good condition ¾ Do not overtake on curves, bridges and slopes
	<ul style="list-style-type: none"> ¾ Adverse weather condition 	<ul style="list-style-type: none"> ¾ Same as above 	<ul style="list-style-type: none"> ¾ Read the road ahead and ride to the left ¾ Keep the wind screen and lights clean ¾ Do not turn at speed ¾ Recognize the hazard, understand the defense and act correctly in time.
	<ul style="list-style-type: none"> ¾ Consuming alcohol before and during the driving operation 	<ul style="list-style-type: none"> ¾ Same as above 	<ul style="list-style-type: none"> ¾ Alcohol and driving do not mix well. Either choose alcohol or driving. ¾ If you have a choice between hitting a fixed object or an on-coming vehicle, hit the fixed object ¾ Quit the steering at once and become a passenger. Otherwise take sufficient rest and then drive. ¾ Do not force the driver to drive fast and round the clock ¾ Do not day dream while driving
	<ul style="list-style-type: none"> ¾ Falling objects/ Mechanical failure 	<ul style="list-style-type: none"> ¾ May prove fatal 	<ul style="list-style-type: none"> ¾ Ensure effective braking system, adequate visibility for the driver, reverse warning alarm ¾ Proper maintenance of the vehicle as per manufacturer instructions
(I) PROOF TESTING (HYDROSTATIC/ PNEUMATIC TESTING)	<ul style="list-style-type: none"> ¾ Bursting of piping ¾ Collapse of tanks ¾ Tanks 	<ul style="list-style-type: none"> ¾ May cause injury and prove fatal 	<ul style="list-style-type: none"> ¾ Prepare test procedure & obtain CONSULTANT/ Owner's approval ¾ Provide separate gauge for pressurizing pump and

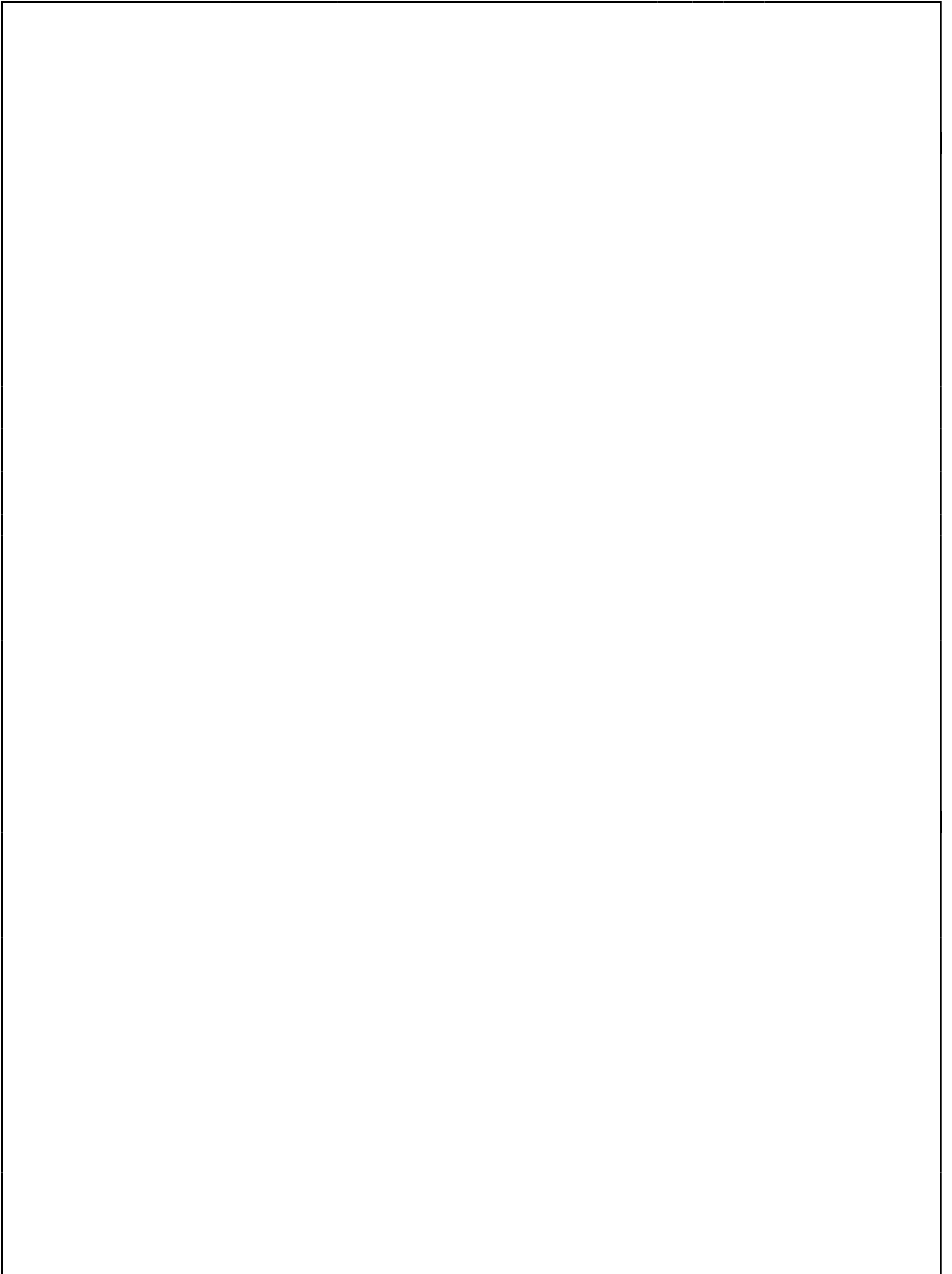

ACTIVITY	TYPE OF HAZARD	EFFECT OF HAZARD	PREVENTIVE MEASURES
	flying off		piping/equipment $\frac{3}{4}$ Check the calibration status of all pressure gauges, dead weight testers and temperature recorders $\frac{3}{4}$ Take dial readings at suitable defined intervals and ensure most of them fall between 40-60% of the gauge scale range $\frac{3}{4}$ Provide safety relief valve (set at pressure slightly higher than test pressure) while testing with air/nitrogen $\frac{3}{4}$ Ensure necessary precautions, stepwise increase in pressure, tightening of bolts/nuts, grouting, etc. before and during testing $\frac{3}{4}$ Keep the vents open before opening any valve while draining out of water used for hydro testing of tanks $\frac{3}{4}$ Pneumatic testing involves the hazard of released energy stored in compressed gas. Specific care must therefore be taken to minimize the chance of brittle failure during a pneumatic leak test. Test temperature is important in this regard and must be considered when the designer chooses the material of construction $\frac{3}{4}$ A pressure relief device shall be provided, having a set pressure not higher than the test pressure plus the lesser of 345 KPa (50 psi) or 10% of the test pressure.
(J) WORKING AT HEIGHTS	$\frac{3}{4}$ Person can fall down	$\frac{3}{4}$ May sustain severe injuries or prove fatal	$\frac{3}{4}$ Provide guard rails/barricade at the work place $\frac{3}{4}$ Use PPE like safety belts, full body harness, life line, helmets, safety shoes, etc. $\frac{3}{4}$ Obtain a permit before starting the work at height above 3 meters $\frac{3}{4}$ Fall arrest systems like safety nets, etc. must be installed $\frac{3}{4}$ Provide adequate working space (min. 0.6 m)

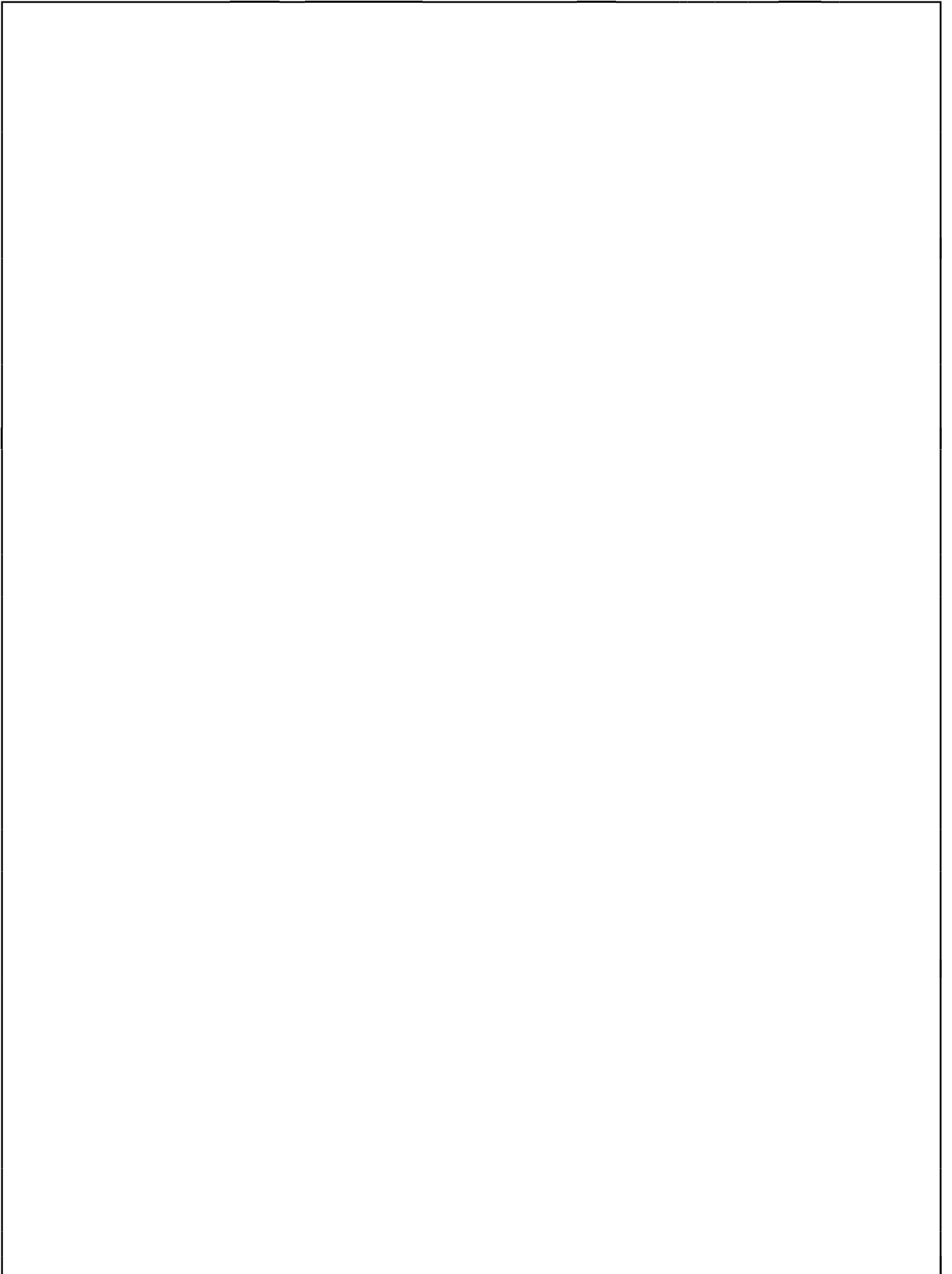

ACTIVITY	TYPE OF HAZARD	EFFECT OF HAZARD	PREVENTIVE MEASURES
			<ul style="list-style-type: none"> ¾ Tie/weld working platform with fixed support ¾ Use roof top walk ladder while working on a slopping roofs ¾ Avoid movement on beams
	¾ Material can fall down	¾ May hit the scrap/material stacked at the ground or in between	<ul style="list-style-type: none"> ¾ Keep the work place neat and clean ¾ Remove the scrap immediately
	¾ Material can fall down	¾ May hit the workers working at lower levels and provide fatal	<ul style="list-style-type: none"> ¾ Same as above plus ¾ Do not throw or drop material or equipment from height ¾ All tools to be carried in a tool-kit bags or on working uniform ¾ Remove scrap from the planks ¾ Ensure wearing of helmet by the workers at low level
(K) CONFINED SPACES	¾ Suffocation/drowning	¾ Unconsciousness, death	<ul style="list-style-type: none"> ¾ Use respiratory devices, if required ¾ Avoid over crowding inside a confined space ¾ Provide Exhaust Fans for ventilation ¾ Do not wear loose clothes, neck ties, etc. ¾ Check for presence of hydrocarbons, O2 level ¾ Obtain work permit before entering a confined space ¾ Ensure that the connected piping of the equipment which is to be opened is pressure free, fluid has been drained, vents are open and piping is positively isolated by a blind flange
	¾ Presence of foul smell and toxic substances	¾ Inhalation can pose threat to life	<ul style="list-style-type: none"> ¾ Same as above plus ¾ Check for hydrocarbon and Aromatic compounds before entering a confined space ¾ Depute one person outside the confined space for continuous monitoring and for extending help in case of an emergency
	¾ Ignition/flame can cause fire	¾ Person may sustain burn injuries or explosion	<ul style="list-style-type: none"> ¾ Keep fire extinguishers at a hand distance ¾ Remove surplus material and scrap immediately

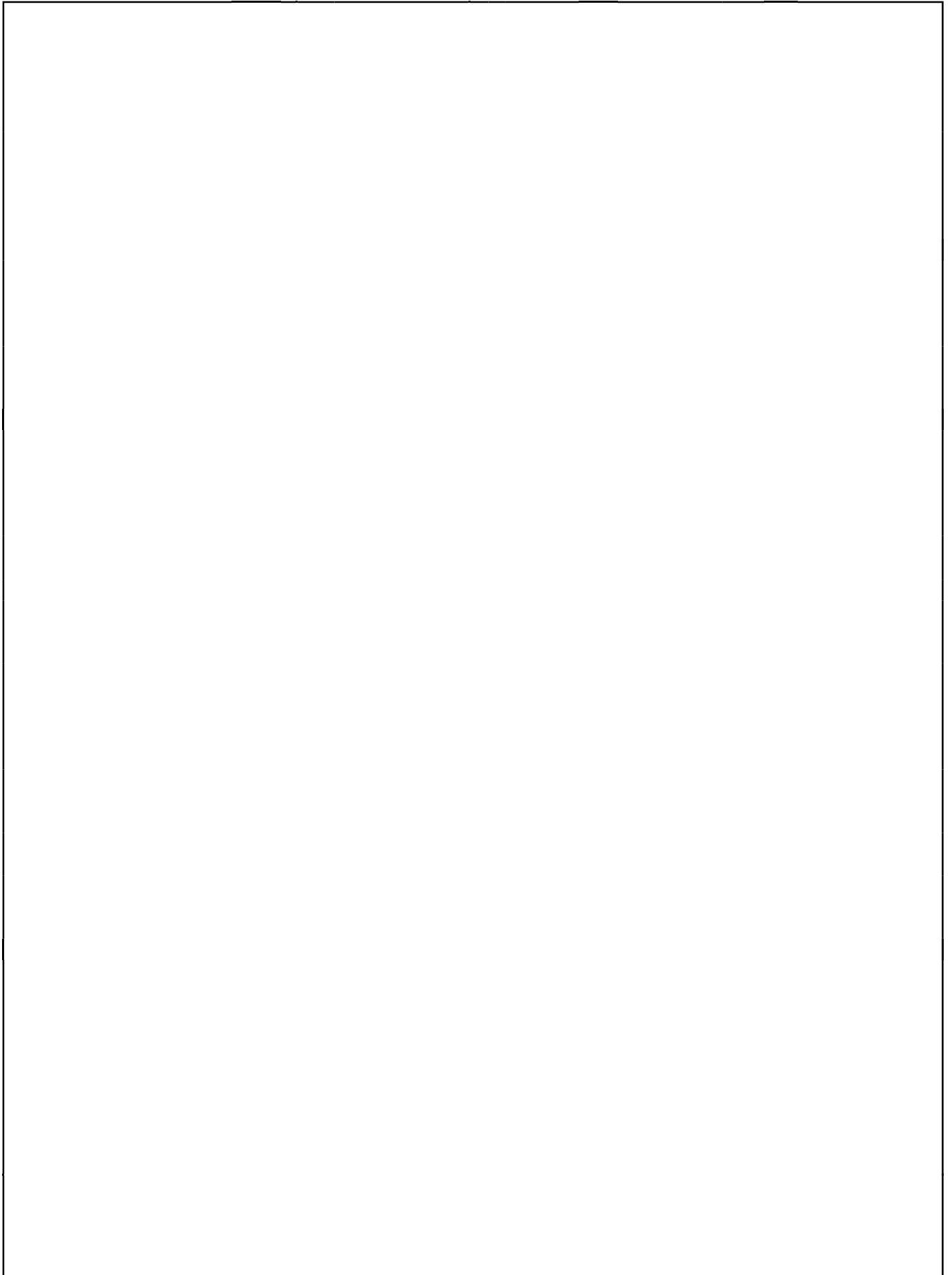

ACTIVITY	TYPE OF HAZARD	EFFECT OF HAZARD	PREVENTIVE MEASURES
		may occur	<ul style="list-style-type: none"> $\frac{3}{4}$ Do not smoke inside a confined space $\frac{3}{4}$ Do not allow gas cylinders inside a confined space $\frac{3}{4}$ Use low voltage (24V) lamps for lighting $\frac{3}{4}$ Use tools with air motors or electric tools with max. voltage of 24V $\frac{3}{4}$ Remove all equipments at the end of the day
(L) HANDLING AND LIFTING EQUIPMENTS	$\frac{3}{4}$ Failure of load lifting and moving equipments	$\frac{3}{4}$ Can cause accident and prove fatal	<ul style="list-style-type: none"> $\frac{3}{4}$ Avoid standing under the lifted load and within the operating radius of cranes $\frac{3}{4}$ Check periodically oil, brakes, gears, horns and tyre pressure of all moving machinery $\frac{3}{4}$ Check quality, size and condition of all chain pulley blocks, slings, U-clamps, D-shackles, wire ropes, etc. $\frac{3}{4}$ Allow crane to move only on hard, firm and leveled ground $\frac{3}{4}$ Allow lifting slings as short as possible and check gunny packings at the friction points $\frac{3}{4}$ Do not allow crane to tilt its boom while moving $\frac{3}{4}$ Install Safe Load Indicator
	$\frac{3}{4}$ Overloading of lifting equipments	$\frac{3}{4}$ Same as above	<ul style="list-style-type: none"> $\frac{3}{4}$ Safe lifting capacity of derricks and winches written on them shall be got verified. $\frac{3}{4}$ The max safe working load shall be marked on all lifting equipments $\frac{3}{4}$ Check the weight of columns and other heavy items painted on them and accordingly decide about the crane capacity, boom and angle of erection $\frac{3}{4}$ Allow only trained operators and riggers during crane operation
	$\frac{3}{4}$ Overhead electrical wires	$\frac{3}{4}$ Can cause electrocution and fire	<ul style="list-style-type: none"> $\frac{3}{4}$ Do not allow boom or other parts of crane to come within 3 m reach of overhead HT cables $\frac{3}{4}$ Hook and load being lifted shall preferably remain in full visibility of crane operator.
(M) SCAFFOLDING,	$\frac{3}{4}$ Person can fall	$\frac{3}{4}$ Person may sustain	$\frac{3}{4}$ Provide guard rails for working at height

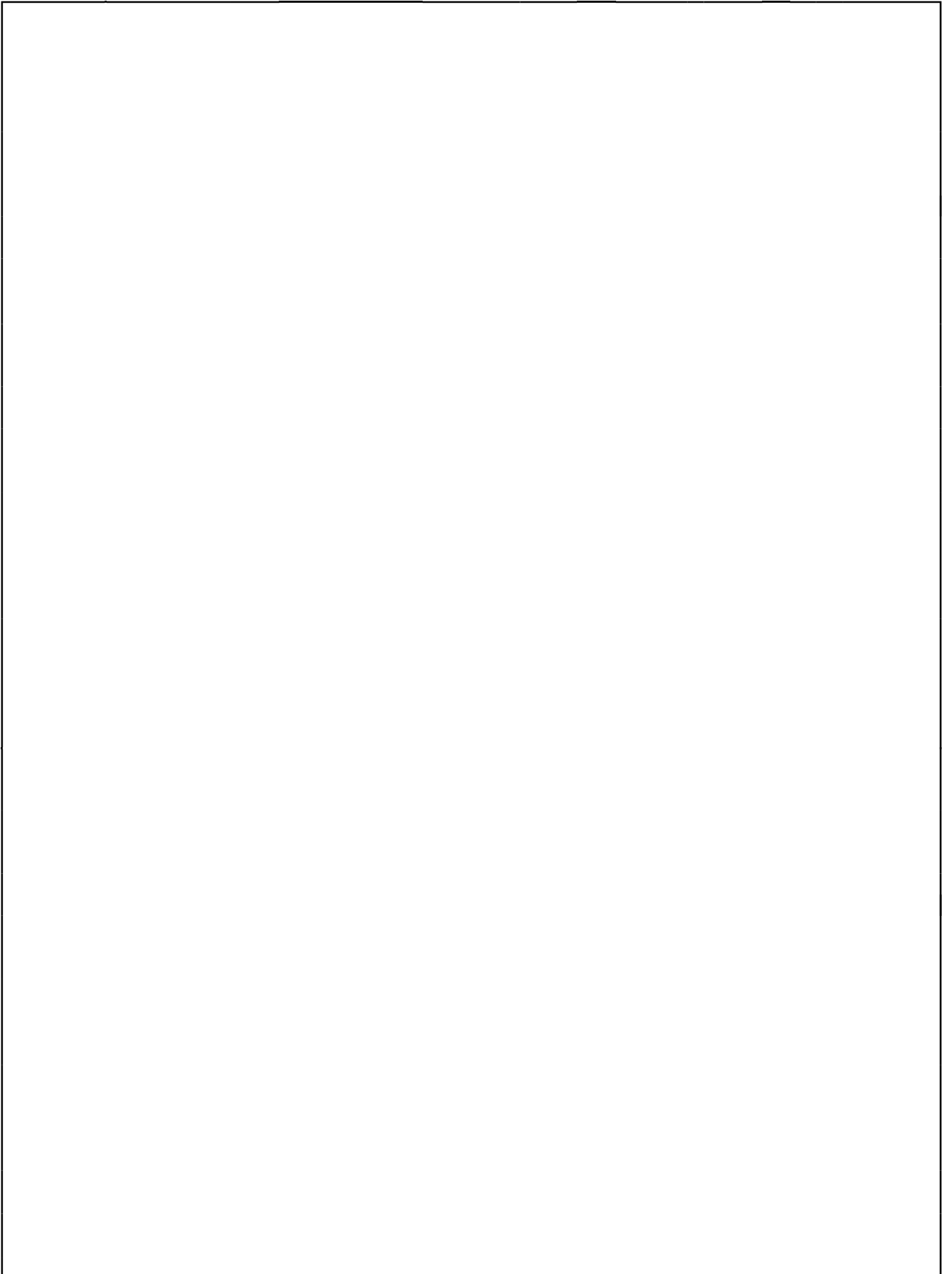

ACTIVITY	TYPE OF HAZARD	EFFECT OF HAZARD	PREVENTIVE MEASURES
FORMWORK AND LADDERS	down	severe injuries and prove fatal	<ul style="list-style-type: none"> $\frac{3}{4}$ Face ladder while climbing and use both hands $\frac{3}{4}$ Ladders shall extend about 1m above landing for easy access and tying up purpose $\frac{3}{4}$ Do not place ladders against movable objects and maintain base at $\frac{1}{4}$ unit of the working length of the ladder $\frac{3}{4}$ Suspended scaffolds shall not be less than 500 mm wide and tied properly with ropes $\frac{3}{4}$ No loose planks shall be allowed $\frac{3}{4}$ Use PPE, like helmets, safety shoes, etc.
	$\frac{3}{4}$ Failure of scaffolding material	$\frac{3}{4}$ Same as above	<ul style="list-style-type: none"> $\frac{3}{4}$ Inspect visually all scaffolding materials for stability and anchoring with permanent structures. $\frac{3}{4}$ Design scaffolding for max. load carrying capacity $\frac{3}{4}$ Scaffolding planks shall not be less than 50x250 mm full thickness lumber or equivalent. These shall be cleared or secured and must extend over the end supports by at least 150mm and not more than 300 mm $\frac{3}{4}$ Don't overload the scaffolds $\frac{3}{4}$ Do not splice short ladders to make a longer one. Vertical ladders shall not exceed 6m.
	$\frac{3}{4}$ Material can fall down	$\frac{3}{4}$ Persons working at lower level gets injured	<ul style="list-style-type: none"> $\frac{3}{4}$ Remove excess material and scrap immediately $\frac{3}{4}$ Carry the tools in a tool-kit bag only $\frac{3}{4}$ Provide safety nets
(N) STRUCTURAL WORKS	$\frac{3}{4}$ Personal negligence and danger of fall	$\frac{3}{4}$ Can cause injury or casualty	<ul style="list-style-type: none"> $\frac{3}{4}$ Do not take rest inside rooms built for welding machines or electrical distribution system $\frac{3}{4}$ Avoid walking on beams at height $\frac{3}{4}$ Wear helmet with chin strap and safety belts when working at height $\frac{3}{4}$ Use hand gloves and goggles during grinding operations $\frac{3}{4}$ Cover or mark the sharp and projected edges $\frac{3}{4}$ Do not stand within the

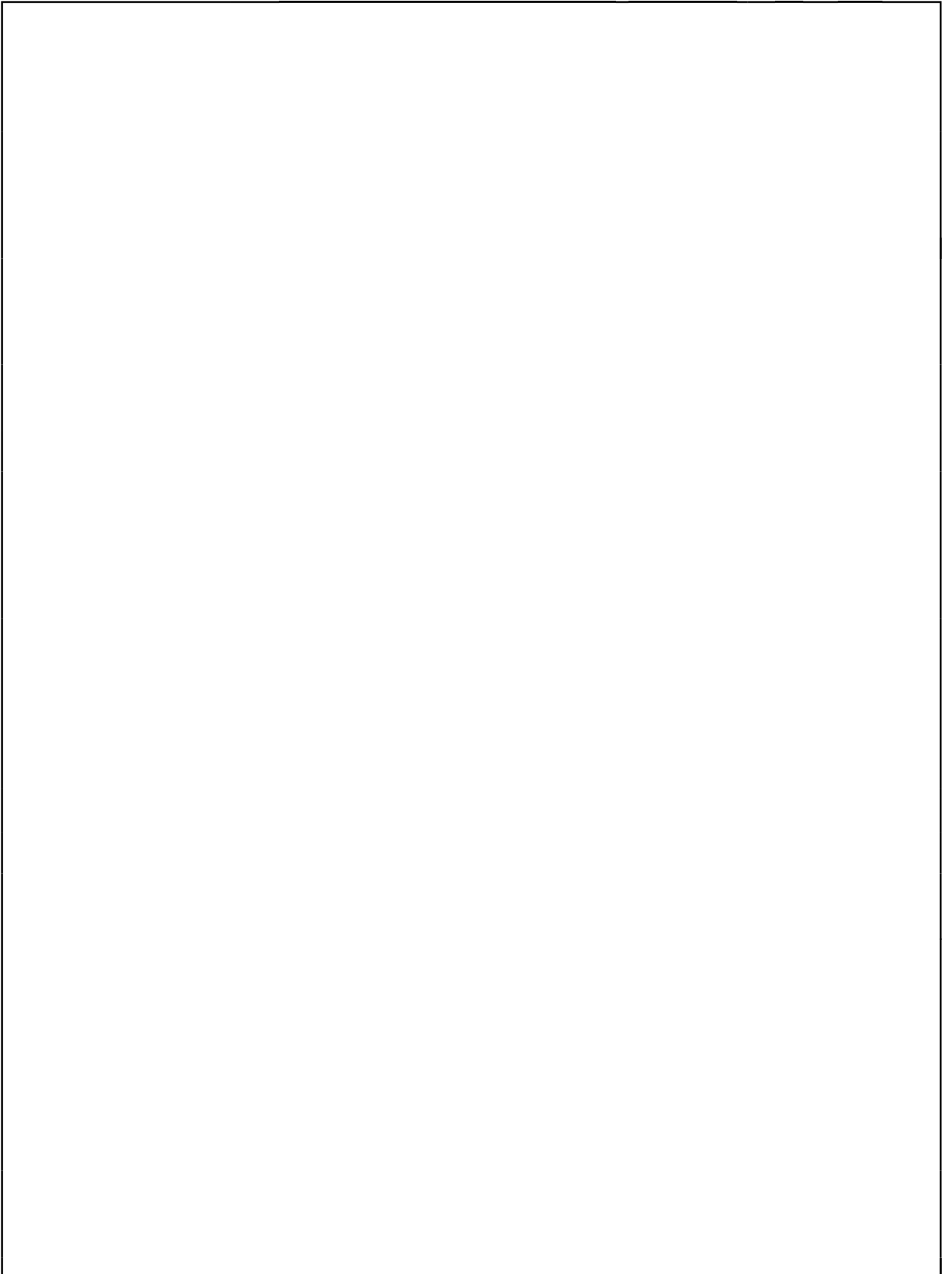

ACTIVITY	TYPE OF HAZARD	EFFECT OF HAZARD	PREVENTIVE MEASURES
	¾ Lifting/s lipping of material	¾ Same as above	operating radius of cranes ¾ Do not stand under the lifted load ¾ Stack properly all the materials. Avoid slippage during handling ¾ Control longer pieces lifted up by cranes from both ends ¾ Remove loose materials from height ¾ Ensure tightening of all nuts and bolts
(O) PIPELINE WORKS	¾ Erectio n/lowering failure	¾ Can cause injury	¾ Do not stand under the lifted load ¾ Do not allow any person to come within the radii of the side boom handling pipes ¾ Check the load carrying capacity of the lifting tools and tackles ¾ Use safe Load Indicators ¾ Use appropriate PPEs
	¾ Other	¾ Same as above	¾ Wear gum boots in marshy areas ¾ Allow only one person to perform signaling operations while lowering of pipes ¾ Provide night caps on pipes ¾ Provide end covers on pipes for stoppage of pigs while testing/cleaning operations

	STANDARD SPECIFICATION FOR HEALTH, SAFETY AND ENVIRONMENT (HSE) MANAGEMENT AT CONSTRUCTION SITES	DOCUMENT NO.	REV
		11-0269-01-18-02-037	0
		SHEET 25 OF 37	

MONTHLY HSE CHECKLIST CUM COMPLIANCE REPORT

PROJECT : CONTRACTOR:

DATE : OWNER :

INSPECTED BY:

Note: Write 'NA' wherever the item is not applicable.

MONTHLY HSE CHECKLIST CUM COMPLIANCE REPORT

SL. NO.	ITEM	YES	NO	REMARKS	ACTION
1	HOUSEKEEPING				
a)	Waste containers provided and used				
b)	Sanitary facilities adequate and clean				
c)	Passageways and Walkways clear				
d)	General neatness of working areas				
e)	Others				
2	PERSONNEL PROTECTIVE EQUIPMENT				
a)	Goggles; Shields				
b)	Face protection				
c)	Hearing protection				
d)	Safety shoes				
e)	Hand protection				
f)	Respiratory Masks etc.				
g)	Safety Belts				
h)	Safety Helmet/Hard Hat				
i)	Others				
3	EXCAVATIONS/OPENINGS				
a0)	Openings properly covered or barricaded				
b)	Excavations shored				
c)	Excavations barricaded				
d)	Overnight lighting provided				
e)	Others				
4	WELDING & GAS CUTTING				
a)	Gas cylinders chained upright				
b)	Cables and hoses not obstructing				
c)	Screens or shields used				
d)	Flammable materials protected				
e)	Fire extinguisher(s) accessible				
f)	Others				
5	SCAFFOLDING				
a)	Fully decked platforms				
b)	Guard and intermediate rails in place				
c)	Toe boards in place				
d)	Adequate shoring				

	STANDARD SPECIFICATION FOR HEALTH, SAFETY AND ENVIRONMENT (HSE) MANAGEMENT AT CONSTRUCTION SITES	DOCUMENT NO.	REV
		11-0269-01-18-02-037	0
	SHEET 26 OF 37		

MONTHLY HSE CHECKLIST CUM COMPLIANCE REPORT

SL. NO.	ITEM	YES	NO	REMARKS	ACTION
	e) Adequate access				
	f) Others				
6	LADDERS				
	a) Extension side rails 1m above				
	b) Top of landing				
	c) Properly secured				
	d) Angle + 70 from horizontal				
	e) Others				
7	HOISTS, CRANES AND DERRICKS				
	a) Condition of cables and sheaves OK				
	b) Condition of slings, chains, hooks and eyes OK				
	c) Inspection and maintenance logs maintained				
	d) Outriggers used				
	e) Signs/barricades provided				
	f) Signals observed and understood				
	g) Qualified operators				
	h) Others				
8	MACHINERY, TOOLS AND EQUIPMENT				
	a) Proper instruction				
	b) Safety devices				
	c) Proper cords				
	d) Inspection and maintenance				
	e) Others				
9	VEHICLE AND TRAFFIC				
	a) Rules and regulations observed				
	b) Inspection and maintenance				
	c) Licensed drivers				
	d) Others				
10	TEMPORARY FACILITIES				
	a) Emergency instructions posted				
	b) Fire extinguishers provided				
	c) Fire-aid equipment available				
	d) Secured against storm damage				
	e) General neatness				
	f) In accordance with electrical requirements				
	g) Others				
11	FIRE PREVENTION				
	a) Personnel instructed				
	b) Fire extinguishers checked				
	c) No smoking in Prohibited Areas				
	d) Hydrants Clear				
	e) Others				
12	ELECTRICAL				
	a) Use of 3-core armoured cables				
	Usage of 'All insulated' or 'double insulated' electrical				
	b) tools				

**STANDARD SPECIFICATION FOR
HEALTH, SAFETY AND
ENVIRONMENT (HSE)
MANAGEMENT AT CONSTRUCTION**

DOCUMENT NO. **REV**
11-0269-01-18-02-037 **0**

MONTHLY HSE CHECKLIST CUM COMPLIANCE REPORT

SL. NO.	ITEM	YES	NO	REMARKS	ACTION
c)	All electrical connection are routed through ELCB				
d)	Natural Earthing at the source of power (main DB)				
e)	Continuity and tightness of earth conductor				
f)	Covering of junction boxes, panels and other energized wiring places				
g)	Ground fault circuit interrupters provided				
h)	Prevention of tripping hazards				
l)	Others				
13	HANDLING AND STORAGE OF MATERIALS				
a)	Properly stored or stacked				
b)	Passageways clear				
c)	Others				
14	FLAMMABLE GASES AND LIQUIDS				
a)	Containers clearly identified				
b)	Proper storage				
c)	Fire extinguishers nearby				
d)	Others				
15	WORKING AT HEIGHT				
a)	Erection plan and work permit obtained				
b)	Safety nets				
c)	Safety belts, full body harness and lanyards, chute lines				
d)	Others				
16	CONFINED SPACE				
a)	Work permit obtained				
b)	Test for toxic gas and sufficient availability of oxygen conducted				
c)	At least one person outside the confined space for monitoring deputed				
d)	Availability of sufficient means of entry, exit and ventilation				
e)	Fire extinguishers and first-aid facility ensured				
f)	Lighting provision made by using 24V lamps				
g)	Proper usage of PPEs ensured				
17	RADIOGRAPHY				
a)	Proper storage and handling of source as per BARG guidelines				
b)	Working permit obtained				
c)	Cordoning of the area done				
d)	Use of appropriate PPE's ensured				
e)	Proper training to workers/supervisors imparted				
f)	Minimum occupancy of workplace ensured				
18	HEALTH CHECKS				
a)	Hygienic conditions at labour camps OK?				
b)	Availability of First-aid facilities				
c)	Proper sanitation at site, office and labour camps				
d)	Arrangement of medical facilities				
e)	Measures for dealing with illness				

	STANDARD SPECIFICATION FOR	DOCUMENT NO.	REV
	HEALTH, SAFETY AND ENVIRONMENT (HSE) MANAGEMENT AT CONSTRUCTION	11-0269-01-18-02-037	0

MONTHLY HSE CHECKLIST CUM COMPLIANCE REPORT

SL. NO.	ITEM	YES	NO	REMARKS	ACTION
f)	Availability of Portable drinking water for workmen & staff				
g)	Provision of crèches for children				
19	ENVIRONMENT				
a)	Chemical and other effluents properly disposed				
b)	Cleaning liquid of pipes disposed off properly				
c)	Seawater used for hydro-testing disposed off as per agreed procedure				
d)	Lubricant Waste/Engine oils properly disposed				
e)	Waste from Canteen, offices, sanitation etc. disposed properly				
f)	Disposal of surplus earth, stripping materials, oily rags and combustible materials done properly				
g)	Green belt protection				

	STANDARD SPECIFICATION FOR HEALTH, SAFETY AND ENVIRONMENT (HSE) MANAGEMENT AT CONSTRUCTION SITES	DOCUMENT NO.	REV
		11-0269-01-18-02-037	0
		SHEET 29 OF 37	

ACCIDENT / FIRE REPORT

(To be submitted by Contractor after every accident within 24 hours of accident)

Report:

Name of Site

Date:

NAME OF THE INJURED
FATHER'S NAME
SUB-CONTRACTOR M/S.
DATE & TIME OF ACCIDENT
LOCATION

BRIEF DESCRIPTION OF ACCIDENT

- CAUSE OF ACCIDENT

- NATURE OF INJURY/DAMAGER

- MEDICAL AID PROVIDED/ACTIONS TAKEN

- INTIMATION TO LOCAL AUTHORITIES

DATE:

**SIGNATURE OF CONTRACTOR
WITH SEAL**

TO : OWNER 1 COPY
RCM/SITE-IN-CHARGE CONSULTANT 1 COPY
CONSULTANT HO Constn. Through RCM 3 COIES
Proj.Mgr. CONSULTANT, Through RCM 1 COPY

	STANDARD SPECIFICATION FOR HEALTH, SAFETY AND ENVIRONMENT (HSE) MANAGEMENT AT CONSTRUCTION SITES	DOCUMENT NO.	REV
		11-0269-01-18-02-037	0
		SHEET 30 OF 37	

SUPPLEMENTARY ACIDENT & INVESTIGATION REPORT

Project:

Supplementary to Report No(Copy enclosed)

Site: Date:

Contractor:

 NAME OF INJURED
 FATHER'S NAME
 SUB-CONTRACTOR M/S.
 DATE & TIME OF ACCIDENT
 LOCATION

BRIEF DESCRIPTION & CAUSE OF ACCIDENT

 - NATURE OF INJURY/DAMAGE

 COMMENTS FROM MEDICAL PRACTITIONER, WHO ATTENDED THE VICTIM/INJURED

 - SUGGESTED IMPROVEMENT IN THE WORKING CONDITION, IF ANY

 - LOSS OF MAN HOURS AND IMPACT ON SITE WORKS

 - ANY OTHER COMMENT BY SAFETY OFFICER

DATE :

**SIGNATURE OF CONTRACTOR
 WITH SEAL**

TO : OWNER 1 COPY
 RCM/SITE-IN-CHARGE CONSULTANT 1 COPY
 CONSULTANT HO Constn. Through RCM 3 COIES
 Proj.Mgr. CONSULTANT, Through RCM 1 COPY

	STANDARD SPECIFICATION FOR HEALTH, SAFETY AND ENVIRONMENT (HSE) MANAGEMENT AT CONSTRUCTION SITES	DOCUMENT NO.	REV
		11-0269-01-18-02-037	0
		SHEET 31 OF 37	

**MONTHLY Health, Safety & Environment (HSE) REPORT
(To be submitted by each Contractor)**

Actual work start Date: For the month of :

Project : Report No. :

Name of the Contractor : Status as on :

Name of work : Name of Safety Officer :

ITEM	THIS MONTH	CUMULTIVE
Total strength (Staff + Workmen)		
Number of HSE meetings organized at site		
Number of HSE awareness programmes conducted at site		
Whether workmen compensation policy taken	Y/N	--
Whether workmen compensation policy is valid	Y/N	--
Whether workmen registered under ESI Act	Y/N	--
Number of Fatal Accidents		
Number of Loss Time Accidents (Other than Fatal)		
Other accidents (Non Loss Time)		
Total number of accidents		
Total man-hours worked		
Man-hour loss due to fire and accidents		
Compensation cases raised with Insurance		
Compensation cases resolved and paid to workmen		
Remarks, if any :		

DATE :

**SIGNATURE OF CONTRACTOR
WITH SEAL**

TO : OWNER 1 COPY
RCM/SITE-IN-CHARGE CONSULTANT 1 COPY

	STANDARD SPECIFICATION FOR HEALTH, SAFETY AND ENVIRONMENT (HSE) MANAGEMENT AT CONSTRUCTION SITES	DOCUMENT NO.	REV
		11-0269-01-18-02-037	0
		SHEET 32 OF 37	

PERMIT FOR WORKING ABOVE 3 METER HIGHT

(Strike out whichever is not applicable)

Project Site : Sr. No.:
 Name of the work: Date:
 Name of Contractor : Nature of Work :
 Total No.of Workers:..... Exact location of work :
 Duration of work: from.....to

The following items have been checked and compliance shall be ensured during the currency of the permit:

Sl.	ITEM	DONE	NOT REQD.
-----	------	------	-----------

1. Equipment/Work Area inspected
2. Considered hazard from other routine/non-routine operations and concerned person alerted
3. ELCB provided
4. Proper lighting provided
5. Area cordoned off.
6. Precautions against public traffic taken
7. Sound Scaffolding provided
8. Adequate protected Platform provided
9. Acces and Exit to the area (Ladder properly fixed)
10. Floor Openings covered
11. Safety Net provided

-
- A. Following personal protective equipment are provided (√ mark) and used as relevant Safety helmet/Gloves/Goggles/Shoes/Face Shield/Life Line/Safety Belt/Safety Harness.
 - B. This permit shall be available at the work site at all times.
 - C. Permit shall be issued for maximum one week only (Monday to Sunday).
 - D. This permit shall be applicable in non-operational areas.
 - E. After completion of the work, used permits shall be preserved for record purposes.
 - F. Additional precautions, if any

Permission is granted to work (See overleaf) = Yes/No.

Name of Contractor's Supervisor
(Initiator)

Name of Contractor's Safety Officer
(Issuing Authority)

	STANDARD SPECIFICATION FOR HEALTH, SAFETY AND ENVIRONMENT (HSE) MANAGEMENT AT CONSTRUCTION SITES	DOCUMENT NO.	REV
		11-0269-01-18-02-037	0
		SHEET 33 OF 37	

HEALTH, SAFETY & ENVIRONMENT (HSE) PLAN

Division/Department :				Project Name :				
Activity/Process	Procedure	Code of	Performer	Checker	Appr over	Sampling Plan		Owner's/ PMC's Audit
Description	Number	Conformance		Reviewer		Reviewer	Approver	Requirements

	STANDARD SPECIFICATION FOR HEALTH, SAFETY AND ENVIRONMENT (HSE) MANAGEMENT AT CONSTRUCTION SITES	DOCUMENT NO. 11-0269-01-18-02-037	REV 0
		SHEET 35 OF 37	

6.0 ELECTRICAL

Electrical power is the mainstay of any construction activity, at the same time it requires utmost care in its utilization to avoid accidents due to electrical shock, fire incidents or electric short circuits. Exposure of electrical installation to adverse environmental conditions increase the risk of such accidents. Hence it is necessary to take extra precautions for such installations to ensure safety of personnel and equipment. This standard addresses the safety measures required to be adopted for the electrical installations by all contractors during construction phase.

All electrical connections/work for electrical installations shall be carried out as per provisions of the latest revision of the following codes and standards in addition to the requirements of statutory authorities and ie rules :

Oisd-std-173 : fire prevention and protection system for electrical installations.

Sp-30 (bis) : national electric code.

The installation shall have approval from concerned statutory authorities.

1. All electrical connections shall be done by an electrician with valid licence and to the satisfaction of engineer-in-charge.
2. One competent licenced electrician shall be made available by contractor at site round the clock to attend to the normal/emergency jobs.
3. All switch boards/welding machines shall be kept in well ventilated and covered shed. The shed shall be elevated to avoid water logging. No flammable materials shall be used for constructing the shed. Also flammable materials shall not be stored in and around electrical equipment/switchboard. Adequate clearances and operational space shall be provided around the equipment.
4. Fire extinguishers and insulating mats shall be provided in all power distribution centres.
5. Temporary electrical equipment shall not be employed in hazardous areas without obtaining safety permit.
6. Proper housekeeping shall be done around the electrical installations.
7. All temporary installations shall be tested before engineering, to ensure proper earthing, bonding, suitability of protection system, adequacy of feeders/cables etc.
8. All welders shall use hand gloves irrespective of holder voltage.
9. Multilingual (english, hindi and local language) caution boards, shock treatment charts and instruction plate containing location of isolation point for incoming supply, name and telephone number(s) of contact person in emergency shall be provided in substations and near all distribution boards/local panels.
10. Operation of earth leakage device shall be checked regularly by temporarily connecting series test lamp (2 bulbs of equal rating connected in series) between phase and earth.
11. The following design features shall be ensured for all electrical installations during construction phase:
 - 12.1 Each installation shall have a main switch with a protective device, installed in an enclosure adjacent to the metering point. The operating height of the main switch shall not exceed 1.5 m. The main switch shall be connected to the point of supply by means of armoured cable.
 - 12.2 The outgoing feeders shall be double or triple pole switches with fuses/mcbs. Loads in a three phase circuit shall be balanced as far as possible and load on neutral should not exceed 20% of load in the phase.
 - 12.3 The installation shall be adequately protected against overload, short circuit and earth leakage by the use of suitable protective devices. Fuses wherever used shall be hrc type. Use of rewirable fuses shall be strictly prohibited. The earth leakage device shall have an operating current not exceeding 30 ma.
 - 12.4 All connections to the handtools/welding receptacles shall be taken through proper switches, sockets and plugs.
 - 12.5 All single phase sockets shall be 3 pin type only. All unused sockets shall be provided with socket caps.
 - 12.6 Only 3 core (p+n+e) overall sheathed flexible cables with minimum conductor size of 1.5 mm² copper shall be used for all hand tools.
 - 12.7 Only metallic distribution boxes with double earthing shall be used at site. No wooden boxes shall be used.
 - 12.8 All power cables shall be terminated with compression type cable glands. Tinned copper lugs shall be used for multistrand wires/cables.
 - 12.9 Cables shall be free from any insulation damage.
 - 12.10 Cables shall be laid underground at a minimum depth of 900 mm, covered with sand, brick and soil for ensuring mechanical protection. Cables shall not be laid in water logged area as far as practicable. Cable route markers shall be provided at every 25 m of buried trench route. When laid above ground,

	STANDARD SPECIFICATION FOR HEALTH, SAFETY AND ENVIRONMENT (HSE) MANAGEMENT AT CONSTRUCTION SITES	DOCUMENT NO.	REV
		11-0269-01-18-02-037	0
		SHEET 36 OF 37	

cables shall be properly cleated or supported on rigid poles of at least 2 m high. Minimum head clearance of 6 meters shall be provided at road crossings.

- 12.11 Under ground road crossings for cables shall be avoided to the extent feasible. In any case no under ground power cable shall be allowed to cross the roads without pipe sleeve.
- 12.12 All cable joints shall be done with proper jointing kit. No taped/temporary joints shall be used.
- 12.13 An independent earthing facility should preferably be established within the temporary installation premises. All appliances and equipment shall be adequately earthed. In case armoured cables are used, the armour shall be bonded to the earthing system.
- 12.14 All cables and wire rope used for earth connections shall be terminated through tinned copper lugs.
- 12.15 In case of local earthing, earth electrodes shall be buried near the supply point and earth continuity wire shall be connected to local earth plate for further distribution to various appliances. All insulated wires for earth connection shall have insulation of green colour.
- 12.16 Separate core shall be provided for neutral earth/structures shall not be used as a neutral in any case.
- 12.17 On/off position of all switches shall be clearly designated/ painted for easy isolation in emergency.
- 12.18 All insulations shall be inspected by engineer-in-charge atleast once in a month.

	STANDARD SPECIFICATION FOR HEALTH, SAFETY AND ENVIRONMENT (HSE) MANAGEMENT AT CONSTRUCTION SITES	DOCUMENT NO.	REV
		11-0269-01-18-02-037	0
		SHEET 37 OF 37	

**AAVANTIKA GAS LIMITED
CITY GAS DISTRIBUTION PROJECT**

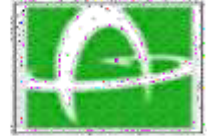

**POLYETHYLENE PIPES FOR UNDERGROUND NETWORKS FOR
NATURAL GAS DISTRIBUTION GENERAL REQUIREMENTS**

CLIENT JOB NO.

-

TOTAL SHEETS

22

DOCUMENT NO

11

0269

02

07

02

001

0	18.10.09	ISSUED FOR CLIENT COMMENTS	AP	SB	SB
A	16.10.09	ISSUED FOR IDC	AP	SB	SB
REV.	DATE	DESCRIPTION	PREP	CHKD	APPD

Polyethylene pipes for underground networks for natural gas distribution General requirements

	POLYETHYLENE PIPES FOR UNDERGROUND NETWORKS FOR NATURAL GAS DISTRIBUTION GENERAL REQUIREMENTS	DOCUMENT NO.	REV
		11-0269-02-07-02-001	0
		SHEET 2 OF 22	

TABLE OF CONTENTS

1. SUBJECT AND AREA OF APPLICATION4

2. REFERENCE STANDARDS AND SPECIFICATIONS4

3. DEFINITIONS.....5

4. MATERIAL SPECIFICATION6

5. CHARACTERISTICS7

6.0 TEST METHODS 11

7. MARKING 14

8. PACKAGING AND STORAGE 15

9. PRODUCT TYPE-APPROVAL 18

APPENDIX 1 19

APPENDIX 2 20

APPENDIX 3 21

APPENDIX 4 22

	POLYETHYLENE PIPES FOR UNDERGROUND NETWORKS FOR NATURAL GAS DISTRIBUTION GENERAL REQUIREMENTS	DOCUMENT NO.	REV
		11-0269-02-07-02-001	0
		SHEET 3 OF 22	

1. SUBJECT AND AREA OF APPLICATION

This specification defines the requirements which must be met by polyethylene (PE) pipes used to construct underground networks for natural gas distribution.

This specification is based on draft standard per EN 1555-2, which states the options and defines supplementary requirements arising from specific provisions on safety and historic constraints relating to our networks.

Testing of the pipes is carried out in accordance with the procedures described in document 11-0269-02-07-02-003 "Polyethylene pipes for underground networks for natural gas distribution - Quality control of pipes".

2. REFERENCE STANDARDS AND SPECIFICATIONS

ISO 760: 1978 Determination of water - Karl Fisher method (General method)

ISO 4437: 1997 Buried polyethylenes (PE) pipes for the supply of gaseous fuels- Metric series- Specifications

ISO 6259-3: 1997 Thermoplastics pipes - Determination of tensile properties-Part 3: Polyolefin pipes

ISO 3126: 1974 Plastic pipes- Measurement of dimensions

ISO 1183: 1987 Plastics - Methods for determining the density and relative density of non-cellular plastics

ISO/DIS 1183-3 Plastics - Methods for determining the density of non- cellular plastics - Part 3: Gas pycnometer method

ISO 2505-1: 1994 Thermoplastics pipes - Longitudinal reversion - Part 1: Determination methods

ISO 2505-2: 1994 Thermoplastics pipes - Longitudinal reversion - Part 2: Determination parameters

ISO 1167: 1996 Thermoplastics pipes for the conveyance of fluids- Resistance to internal pressure- Test method

EN 728:1997 Plastics piping and ducting systems - Polyolefin pipes and fittings - Determination of oxidation induction time.

EN 1056: 1996 Plastics piping and ducting systems - Plastics pipes and fillings - Method for exposure to direct (natural) weathering.

prEN 1555-1: 2001 Plastics piping systems for the supply of gaseous fuels- Polyethylene (PE)-Part 1: General.

prEN 1555-2: 2001 Plastics piping systems for the supply of gaseous fuels - Polyethylene (PE) - Part 2: Pipes.

EN ISO 12162: 1995 Thermoplastics materials for pipes and fittings for pressure applications- Classification and designation-Overall service (design) coefficient.



POLYETHYLENE PIPES FOR
UNDERGROUND NETWORKS FOR
NATURAL GAS DISTRIBUTION
GENERAL REQUIREMENTS

DOCUMENT NO.

11-0269-02-07-02-001

SHEET 4 OF 22

REV

0

- EN ISO 13479 Polyolefin pipes for the conveyance of fluids - Determination of resistance to crack propagation - Test method for slow crack growth on notched pipes (notch test).
- ISO 4440-1: 1994 Thermoplastics pipes and fittings - Determination of melt mass-flow rate - Part 1: Test method.
- ISO DIS 9080 Plastics piping and ducting systems - Determination of the long-term hydrostatic strength of thermoplastics materials in pipe form by extrapolation.
- ISO 13477: 1997 Thermoplastics pipes for the conveyance of fluids - Determination of resistance to rapid crack propagation (RCP) - Small-scale-steady-state test (S4 test).
- IS 14885: 2022 Polyethylene pipes for the supply of Gaseous Fuels-Specifications.
- 11-0269-02-07-02-005 Polyethylene compounds for the manufacture of pipes and fittings for Underground natural gas distribution networks. Acceptance procedure.

3. DEFINITIONS

3.1. BATCH OF COMPOUND

By batch of compound is meant a homogeneous quantity of PE compound of the same origin and of a particular brand.

The batch must be registered under a single identification number (batch number) which leaves no doubt as to the origin, identity and date of manufacture of the compound.

3.2. BATCH OF PIPES

By batch of pipes is meant a homogenous lot of pipes with identical dimensions, made in a continuous process by the same extrusion machine and from the same batch of compound.

3.3. MINIMUM REQUIRED STRENGTH (MRS 10)

Standardized class of compounds for which the Lower Confidence Limit (LCL) is equal to 10.

3.4. PE 100

	POLYETHYLENE PIPES FOR UNDERGROUND NETWORKS FOR NATURAL GAS DISTRIBUTION GENERAL REQUIREMENTS	DOCUMENT NO.	REV
		11-0269-02-07-02-001	0
		SHEET 5 OF 22	

Standard designation for PE compounds in class MRS 10.

For such PE compounds, the long-term hydrostatic strength — calculated and classified according to the standardized method (ISO 9080 and ISO 12162) for a temperature of 20°C, a period of 50 years and a reliability of 97.5 % — must be at least 10 MPa.

3.5 LOWER CONFIDENCE LIMIT (LCL)

A quantity with the dimensions of stress, in Megapascal, which can be considered as a property of the material under consideration and represents the 97.5% lower confidence limit of the predicted long-term hydrostatic strength at a temperature of 20°C for 50 years with internal water pressure.

3.6 Standard Dimensions Ratio (SDR)

SDR is the quotient of the nominal outside diameter and the nominal wall thickness (expressed rounded to one decimal)

$$SDR = d_e / e_n$$

d_e = nominal diameter of pipe

e_n = nominal thickness of pipe in mm

3.7 Overall Service (Design) Co-efficient (C)

C is an overall co-efficient with a value greater than 1 which takes into consideration service condition as well as properties of the components of a piping system other than those represented in the lower confidence limit. For this specification the minimum of C is 2.0

3.8 Maximum Allowable Operating Pressure (MAOP)

The highest effective pressure of the gas in the pipeline system expressed in bar, which is allowed in continuous use. It takes into account the physical and the mechanical characteristics of the components of the piping system.'

It is given by the equation:

$$MAOP = (20 \times MRS) / (C \times (SDR - 1))$$

4. MATERIAL SPECIFICATION

The PE compounds that are acceptable shall conform to the requirements for PE 100 described in prEN1555-1.

In order to be approved, materials shall conform with the WGI technical specification 11-0269-02-07-02-005 "Polyethylene compounds for manufacture of pipes and fittings for underground networks for natural gas distribution - Acceptance procedure."

Approved materials are listed in Appendix 1.

	POLYETHYLENE PIPES FOR UNDERGROUND NETWORKS FOR NATURAL GAS DISTRIBUTION GENERAL REQUIREMENTS	DOCUMENT NO.	REV
		11-0269-02-07-02-001	0
		SHEET 6 OF 22	

Characteristics of PE Compound are given in Appendix 3.

Following are forbidden:

- a. use of recycled materials;
- b. mixture of different materials;
- c. addition of complementary materials by the pipe manufacturer.

5. CHARACTERISTICS

5.1. RAW MATERIAL

All the characteristics of the PE Compound are in accordance with the provisions of prEN 1555-1 or IS 14855 for PE 100 materials and for the limit values listed in the table in Appendix 3.

5.2. PIPES

5.2.1. Physical characteristics

5.2.1.1. Appearance of pipes

The appearance of the pipes is checked in accordance with 6.1.

The pipes must be square cut with smooth trimmed ends.

The internal and external surfaces of the pipes, examined visually without magnification, are uniform and smooth.

The pipes are free of scratches, pits, voids, blisters, occlusions or cracks.

5.2.1.2. Colour

The pipes shall be orange in accordance with the local requirements.

5.2.1.3. Density

	POLYETHYLENE PIPES FOR UNDERGROUND NETWORKS FOR NATURAL GAS DISTRIBUTION GENERAL REQUIREMENTS	DOCUMENT NO.	REV
		11-0269-02-07-02-001	0
		SHEET 7 OF 22	

Density is measured in accordance with the provisions of § 6.2. The measured value must correspond to the data listed in the table in Appendix 3, allowing for possible differences caused by measuring on the pipe instead of granulate.

5.2.1.4. Melt mass-flow rate (MFR)

The melt mass-flow rate MFR (190°C - 5 kg), measured on a sample taken from the pipe in accordance with 6.3., is within the limits stated in the table in Appendix 3: characteristics of PE Compound.

In addition, the discrepancy in absolute value between the MFR measured on a pipe sample and that measured on a sample of raw material may not exceed 20% of the latter.

5.2.1.5. Volatile content

The volatile content, measured on a pipe sample in accordance with Clause 6.4., may not exceed 350 mg/kg.

5.2.1.6. Water content

The water content may be estimated by measuring the volatile content.

If the volatile content, measured in accordance with 6.4., is more than 250 mg/kg, the water content must be ascertained.

The water content, measured in accordance with 6.5., must be 250 mg/kg or less.

5.2.1.7. Thermal stability (OIT)

Thermal stability is measured in accordance with § 6.6 on samples taken from the wall at random.

The minimum oxidation induction time at 210°C is 20 minutes. The maximum admissible decrease in the oxidation induction time measured on a pipe sample compared to that measured on the raw material, may not exceed 20% of the latter.

5.2.1.8. Resistance to atmospheric influence

Resistance to atmospheric influence is tested in accordance with § 6.7.

The exposure dose corresponds to a total energy of at least 3.5 GJ/m².

	POLYETHYLENE PIPES FOR UNDERGROUND NETWORKS FOR NATURAL GAS DISTRIBUTION GENERAL REQUIREMENTS	DOCUMENT NO.	REV
		11-0269-02-07-02-001	0
		SHEET 8 OF 22	

After testing, the pipe sample must meet the specifications laid down in § 5.2.1.7 (thermal stability), 5.2.2.2 (resistance to internal hydraulic pressure) and 5.2.2.5 (stress at yield point and elongation to fracture). In the latter test, only elongation to fracture is taken into consideration.

5.2.2. Mechanical characteristics -

5.2.2.1. Internal stresses

Internal stresses are measured in accordance with § 6.8. The variation in length between the reference points must be 3% or less.

5.2.2.2. Resistance to internal hydraulic pressure

The tests are carried out in accordance with §6.9. The test specimens taken from a batch of pipes show no leakage in the conditions of temperature, wall stress and test length stated in the tables in Appendix 4: resistance to internal hydraulic pressure.

If, for a given material, during the test at 80°C - 165 hrs with the highest wall stress σ , fracture occurs before the specified time and is ductile in nature, the tests are repeated with a minimum time of 1,000 hrs and the corresponding wall stress level as specified in Appendix 4.

5.2.2.3. Resistance to slow cracking (Notch test)

The test is carried out on pipes with a nominal diameter ≥ 90 using the test method stated at 6.10. No fracture will occur on the samples for test periods of less than 500 hrs.

5.2.2.4. Resistance to growth of cleavage fractures

Pipes with a diameter ≥ 90 are tested in accordance with the test described at § 6.11. The critical pressure at 0°C is at least 3 bar.

5.2.2.5. Stress at yield point and elongation to fracture

The test is carried out as described at CI 6.12.

The minimum stress at the yield point is defined in the table "Characteristics of PE Compound" (Appendix 3).

	POLYETHYLENE PIPES FOR UNDERGROUND NETWORKS FOR NATURAL GAS DISTRIBUTION GENERAL REQUIREMENTS	DOCUMENT NO.	REV
		11-0269-02-07-02-001	0
		SHEET 9 OF 22	

Elongation to fracture must be more than 350% for each test specimen.

5.2.3 Dimensional characteristics

The dimensions are measured in accordance with 6.13.

5.2.3.1. Series

The pipes belong to either series SDR 11 or 17.6 in table A below as per 14885:2022 :

TABLE A

Nominal Diameter d_e	Thickness e_n (mm)	
	SDR 11	SDR 17.6
20	3.0	1
32	3.0	2.3
63	5.8	3.8
125	11.4	7.4
180	16.4	10.7

5.2.3.2. Length

The length of the pipes is specified in the order. The preferred lengths are defined in §8.2.

The tolerances for straight pipes are: - 0 / + 0.05 m

The tolerances for rolled pipes are: - 0 / + 0.50 m

5.2.3.3. Mean external diameter D_m

The extreme mean external diameters are stated in ISO 4437.

5.2.3.4. External diameter D - ovalisation

The maximum deviation permitted in relation to nominal diameter d_e is given ISO 4437.

In the event of dispute regarding the dimensions of rolled pipes, the dimensions shall be reviewed 24

	POLYETHYLENE PIPES FOR UNDERGROUND NETWORKS FOR NATURAL GAS DISTRIBUTION GENERAL REQUIREMENTS	DOCUMENT NO.	REV
		11-0269-02-07-02-001	0
		SHEET 10 OF 22	

hours after the pipe has been unrolled.

5.2.3.5. Thickness

The thicknesses are given in table 6 and have been taken from 14885:2022.

5.2.4 Reversion Test

When tested as per Clause 6.14, the value of longitudinal reversion shall not be greater than 3%.

5.2.5 Tensile Test

When tested in accordance with Cl. 6.15 at $23 \pm 1^{\circ}\text{C}$ at a speed of 100 mm/min \pm 10% for specimen thickness below 5 mm and at a speed of 25 mm/min for thickness above 5mm, the value obtained shall be as follows:

Tensile yield strength	15 MPa, Min
Elongation at Break	350 %, Min

5.2.6 Squeeze off

On all sizes of pipe up to and including 400 mm diameter, strength after squeeze-off and subsequent re-rounding, must be demonstrated by testing as per Cl. 6.16.

5.2.7 Pigment Dispersion

When tested as per Annex E of IS 14885, the grading should be ≤ 3 .

6.0 TEST METHODS

6.1. APPEARANCE

The pipes are presented on suitable work surfaces and examined visually.
A suitable artificial lighting system is used to examine their internal appearance.

6.2. DENSITY

The density is tested using the method described in ISO 1183, with the result expressed in kg/m^3 .

6.3. MELT MASS-FLOW RATE (MFR)

The melt mass-flow rate shall be ascertained in accordance with standard ISO 4440-1 or IS-14885.

	POLYETHYLENE PIPES FOR UNDERGROUND NETWORKS FOR NATURAL GAS DISTRIBUTION GENERAL REQUIREMENTS	DOCUMENT NO.	REV
		11-0269-02-07-02-001	0
		SHEET 11 OF 22	

6.4. DETERMINATION OF VOLATILE CONTENT

The volatile content is checked using the method described in ISO 4437/IS 14885.

6.5. DETERMINATION OF WATER CONTENT USING KARL FISCHER METHOD

The water content is measured using the Karl Fischer method described ISO 760.

6.6. THERMAL STABILITY (OIT)

The test is carried out in accordance with the minimum oxidation induction time (OIT) of the material from the product shall be ≥ 20 min when tested as per Annex. D of IS 14885.

6.7. RESISTANCE TO ATMOSPHERIC INFLUENCE

Resistance to atmospheric influence is tested in accordance with the specifications of standard EN 1056.

Artificial exposure is also acceptable, provided it can be proved that the test is equivalent to the natural exposure test.

6.8. INTERNAL STRESSES

Internal stresses are measured using the methods described in ISO 2505.

The test temperature is $110 \pm 2^\circ\text{C}$.

Table B states the time depending on the thickness of the pipe and the method used.

Table B

Wall Thickness mm	Time in minutes	
	Bath	Stove
$e < 8$	15	60
$8 \leq e < 16$	30	120
$16 \leq e$	60	240

	POLYETHYLENE PIPES FOR UNDERGROUND NETWORKS FOR NATURAL GAS DISTRIBUTION GENERAL REQUIREMENTS	DOCUMENT NO.	REV
		11-0269-02-07-02-001	0
		SHEET 12 OF 22	

6.9. RESISTANCE TO INTERNAL HYDRAULIC PRESSURE

The test method is that described in ISO 1167.

The test pressure is calculated using the following formula, based on the nominal diameters and thicknesses.

$$P = 10 \cdot \sigma(2 \cdot e_n) / (d_e - e_n)$$

where

σ = pipe wall stress in MPa

d_e = nominal diameter of pipe

e_n = nominal thickness of pipe in mm

p = test pressure in bar

In the event of dispute, the test pressure shall be calculated on the basis of the diameters and thicknesses measured.

The test specimens taken from a batch of pipes show no leakage in the conditions of temperature, wall stress and test length stated in the tables in Appendix 4: resistance to internal hydraulic pressure.

Fractures at 80°C must be of the cleavage type. The minimum fracture time is defined by the straight line at 80°C connecting the points specified in the tables in Appendix 4.

If the pressure and/or temperature limits specified are exceeded, this is noted in the report stating the reason and scale (times and limit values).

If during the minimum specified time the pressure and/or temperature have exceeded the upper limits determined by the standard, the test is taken into consideration if the cracking time is higher than the specified minimum. Otherwise, the test must be repeated.

On the other hand, the test must be repeated if the pressure and/or temperature fall below the lower limits.

6.10. RESISTANCE TO SLOW CRACKING (NOTCH TEST)

	POLYETHYLENE PIPES FOR UNDERGROUND NETWORKS FOR NATURAL GAS DISTRIBUTION GENERAL REQUIREMENTS	DOCUMENT NO.	REV
		11-0269-02-07-02-001	0
		SHEET 13 OF 22	

The test is carried out in accordance with EN ISO 13479 at 80°C on a notched pipe with a wall stress of 4.6 MPa.

6.11. RESISTANCE TO GROWTH OF CLEAVAGE FRACTURES

Resistance to the growth of cracks is tested using test S4 described in standard ISO 13477.

The test temperature is 0°C and the knife speed 20 m/sec.

6.12. STRESS AT YIELD POINT AND ELONGATION TO FRACTURE

The test is carried out in accordance with ISO 6529-3.

In the case of pipes with coextruded yellow lines, all test specimens must be taken such that the yellow marking axis coincides with the longitudinal axis of the test specimen.

For thicknesses of less than 12 mm, the test specimens shall be cut using a hollow punch.

The traction speed is 100 mm/min.

6.13. DIMENSIONS

All dimensions, except for lengths, are measured at a temperature of $23 \pm 2^\circ\text{C}$ using the methods described in ISO 3126.

6.14 Reversion Test

Shall be tested in according to the procedure given in Annex. C of IS 14885

6.15 Tensile Test

Shall be tested according to the procedure given in Annexure J of IS 14885.

6.16 Squeeze off

Shall be tested in accordance with Annexure G of IS 14885.

7. MARKING

The marking is repeated at least once per metre. This marking is done on two diametrically opposite generating lines. The empty space between two technical data is filled by alternate repetition of the word "GAS".

	POLYETHYLENE PIPES FOR UNDERGROUND NETWORKS FOR NATURAL GAS DISTRIBUTION GENERAL REQUIREMENTS	DOCUMENT NO.	REV
		11-0269-02-07-02-001	0
		SHEET 14 OF 22	

Marking must be indelible and visible in colour.

The stamping must not affect the quality of the pipe.

The minimum height of the characters must be:

- 3 mm for nominal diameters ≤ 63
- 5 mm for nominal diameters ≥ 110 .

The depth of the marking must be ≤ 0.1 mm in the case of pipes with a nominal diameter ≤ 110 and ≤ 0.2 mm in the case of pipes with larger diameters.

Marking of the pipes shall include, in the following order, on each generating line:

- the word "GAS";
- the nominal diameter and the thickness of the wall;
- the SDR series;
- the date of manufacture (year, month, day);
- the work team in Roman numerals;
- the commercial name or code of the resin used (see Appendix 2);
- the code of the extrusion machine;
- the name or style of the manufacturer.

Any other marking, either in terms of the application technique or the data specified, must be submitted to the Company for approval in advance.

8. PACKAGING AND STORAGE

8.1. GENERAL

The manufacturer shall take all necessary action to prevent the pipes from deteriorating during storage, loading and transport.

	POLYETHYLENE PIPES FOR UNDERGROUND NETWORKS FOR NATURAL GAS DISTRIBUTION GENERAL REQUIREMENTS	DOCUMENT NO.	REV
		11-0269-02-07-02-001	0
		SHEET 15 OF 22	

The pipes may be supplied in straight lengths or in rolls. Straight lengths are normally placed in crates.

The pipes are fitted with sealing devices at both ends, of a model approved by the Company.

8.2. LENGTHS

The preferred pipe lengths are given in table C below.

TABLE C

Nominal diameter de	Preferred Length in meters		
	Reels		Straight pipes
20	200		-
32	200		-
63	100		-
125	50		
180	-		12

The lengths to be supplied are specified in the order.

The lengths to be supplied are specified in the SOR order.

8.3. PACKAGING

8.3.1. Packaging of straight pipes

If the pipes are supplied in crates, these must correspond to the diagram in Appendix 5.

The wooden framework is banded using galvanized steel hoops. The tension of the hoops is such that the pieces of wood forming the framework are in contact with one another and the overlap of the crosspieces on the uprights is 2/3 the thickness of the latter.

8.3.2. Packaging of rolled pipes

Each roll includes an adequate number of hoops made from cords or bands of synthetic material, evenly distributed around the whole circumference of the bundle. In each case there must be a hoop less than 0.3 m from each end of the pipes.

The packaging must on no account adulterate the pipe.

	POLYETHYLENE PIPES FOR UNDERGROUND NETWORKS FOR NATURAL GAS DISTRIBUTION GENERAL REQUIREMENTS	DOCUMENT NO.	REV
		11-0269-02-07-02-001	0
		SHEET 16 OF 22	

8.4. HANDLING AND STORAGE

Immediately after production, pipes shall be handled with great care from the production line to the storage place, in order to avoid any damage such as scratches, notches, superficial wear and tear, holes, dented walls or similar.

If handled by forklift or similar equipment, the metallic forks shall be covered with a soft material in order to avoid any damage to the pipes.

The extremities of the pipes shall not be in contact with the floor while handling.

Indoor storage is preferred.

Outdoor storage is permitted at the following conditions:

- Storage periods are not exceeding one month
- Pipes are protected from direct sunlight by a suitable shelter
- Pipes are stored on a hard storage surface clean from excessive dust, stones, water etc.
- Pipes are not in contact with the soil, but are supported by soft material such a wood etc.
- Pipes are protected from damages caused by traffic of forklifts, trucks etc.

8.5 SEALS

Prior to execution of the order, the manufacturer must submit to the Company the seals which it intends to use for all the types of pipes ordered.

The seals shall preferably be made of PE or a material which does not adulterate polyethylene. Metal and PVC seals are not permitted. The seals must be able to withstand storage times as guaranteed in § 8.6. of this specification, and also to withstand handling during installation.

They must not be brittle or sharp and the materials, shapes and dimensions thereof must be such that they cannot fully penetrate inside the pipes.

They are of the internal plug type for all pipes supplied in straight lengths, and for pipes rolled in coils or on reels, the seals may be caps.

	POLYETHYLENE PIPES FOR UNDERGROUND NETWORKS FOR NATURAL GAS DISTRIBUTION GENERAL REQUIREMENTS	DOCUMENT NO.	REV
		11-0269-02-07-02-001	0
		SHEET 17 OF 22	

All seals are fitted with a valve to prevent pressurization or depressurizations of the pipes, depending on climatologically temperature cycles.

In theory, they are placed on the pipes immediately after completion of the manufacturing tests, but before storage of the pipes. In the event of acceptance, the pipe plugs are removed and replaced by the supplier.

The seals cannot be recycled after the pipes have been installed. Their removal on site should not require the use of special tools.

8.5. STORAGE WARRANTY

It must be possible to store the pipes in the open air, protected from direct sunlight, without taking any other special precautions for at least two years from the date of manufacture stated on the pipe.

The storage warranty covers continued conformity of the dimensions, characteristics and performances laid down in this specification.

8.6. DEADLINE FOR SUPPLY

The pipes must be supplied to the user within one month following the date of manufacture.

9. PRODUCT TYPE-APPROVAL

For the purposes of type-approval of the product, the manufacturer is obliged to supply a technical file as defined in WGI procedure 11-0269-02-07-02-007

Type-approval of the products is carried out in accordance with the aforementioned procedure.

Any change to the type-approved product, process or manufacturing equipment must be notified to the Company in writing.

Any failure in this respect shall incur withdrawal of type-approval until termination of the contract.

	POLYETHYLENE PIPES FOR UNDERGROUND NETWORKS FOR NATURAL GAS DISTRIBUTION GENERAL REQUIREMENTS	DOCUMENT NO.	REV
		11-0269-02-07-02-001	0
		SHEET 18 OF 22	

APPENDIX 1

Approved materials

The materials which have passed the “WGI” approval procedure for PE materials (“11-0269-02-07-02-007”) are approved for manufacture of the pipes.

For information, the following materials have been approved to date:

Solvay Eltex TUB 121 (black)	PE 100
or Eltex TUB 125 (orange)	
Borealis HE 2490	PE 100
Fina Finathene XS 10 B	PE 100
Dow BG 10050	PE 100
Elenac Hostalen CRP 100	PE 100

	POLYETHYLENE PIPES FOR UNDERGROUND NETWORKS FOR NATURAL GAS DISTRIBUTION GENERAL REQUIREMENTS	DOCUMENT NO.	REV
		11-0269-02-07-02-001	0
		SHEET 19 OF 22	

APPENDIX 2

Code for different raw materials

Manufacturer	Commercial brand name		Code (*)
SOLVAY	ELTEX	TUB 121/125	E3
BOREALIS		HE 2490	N3
FINA	FINATHENE	XS 10 B	F3
DOW		BG10050	D1
ELENAC	HOSTALEN	CRP100	H7

*Based on the GERG List

	POLYETHYLENE PIPES FOR UNDERGROUND NETWORKS FOR NATURAL GAS DISTRIBUTION ENERAL REQUIREMENTS	DOCUMENT NO.	REV
		11-0269-02-07-02-001	0
		SHEET 20 OF 22	

APPENDIX 3

Characteristics of PE Compound

Characteristics	Units	Requirements	Test Parameters	Test Method
Conventional density	kg/m ³	>=928.4(base Polymer) >=928.4(base Polymer)	23 ⁰ C 27 ⁰ C	IS 7328:1992 ¹⁾
Melt flow rate	g/10 min	+/- 20 % of value nominated by compound producer	190 ⁰ C /5.0 Kg	IS 2530:1963
Thermal Stability	min	>= 20	200 ⁰ C	Annex D of IS 14855
Resistance to gas Constituents	h	>= 20	80 ⁰ C	Clause 5.5
Pigment Dispersion	Grade	<= 3		Annex E of IS 14855

1) See Explanatory Notes at Annex L

NOTE — Indian testing methods mentioned in IS 7328 and IS 2530 for the determination of conventional density and mass flow rate have been found co-related with ISO/British Standard Testing methods, such as ISO 1183-1983(E), ISO 1133-1991(E), ISO 6964 and BS 2782 Part 8, method 823-A, 823-B, 1978 respectively. The compound shall confirm to the weathering requirements for thermal stability as above, hydrostatic strength HS (165 h-80°C) at induced stress 4.6 MPa and 5.5 MPa for PE- 80 and PE-100 material respectively and elongation at break 350 percent minimum after exposure of the test as per Annex F.

	POLYETHYLENE PIPES FOR UNDERGROUND NETWORKS FOR NATURAL GAS DISTRIBUTION GENERAL REQUIREMENTS	DOCUMENT NO.	REV
		11-0269-02-07-02-001	0
		SHEET 21 OF 22	

APPENDIX 4

Resistance to internal hydraulic pressure

Specification of test parameters

PE 100 materials (MRS10)

Test type	Minimum Time hours	Type of fracture
20 ⁰ C- $\sigma \geq 12.4$ MPa	100	ductile
40 ⁰ C- $\sigma \geq 5.5$ MPa	165	cleavage
80 ⁰ C- $\sigma \geq 5.0$ MPa	1000	-

If a ductile fracture occurs during the test at 80°C - 165 hrs, the test is repeated for 1,000 hrs at a lower stress level.

	POLYETHYLENE PIPES FOR UNDERGROUND NETWORKS FOR NATURAL GAS DISTRIBUTION GENERAL REQUIREMENTS	DOCUMENT NO.	REV
		11-0269-02-07-02-001	0
		SHEET 22 OF 22	

**AAVANTIKA GAS LIMITED
CITY GAS DISTRIBUTION PROJECT**

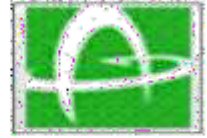

**POLYETHYLENE PIPES FOR UNDERGROUND NETWORKS FOR
NATURAL GAS DISTRIBUTION - TECHNICAL DATASHEET**

CLIENT JOB NO.

-

TOTAL SHEETS

05

DOCUMENT NO

11

0269

02

07

02

002

REV.	DATE	DESCRIPTION	PREP	CHKD	APPD
0	18.10.09	ISSUED FOR CLIENT COMMENTS	AP	SB	SB
A	16.10.09	ISSUED FOR IDC	AP	SB	SB

Polyethylene pipes for underground networks for natural gas distribution Technical Datasheet



POLYETHYLENE PIPES FOR
UNDERGROUND NETWORKS FOR
NATURAL GAS DISTRIBUTION
TECHNICAL DATASHEET

DOCUMENT NO.

11-0269-02-07-02-002

REV

0

SHEET 2 OF 5

TABLE OF CONTENTS

1.0 REFERENCE DOCUMENTS 4

The information contained in this document should be treated as confidential and is to be considered as exclusive property of WGI.

Direct or Indirect use of this document or any part of it is only allowed for WGI productions

POLYETHYLENE PIPES FOR UNDERGROUND NETWORKS FOR NATURAL GAS DISTRIBUTION TECHNICAL DATASHEET	DOCUMENT NO.	REV
	11-0269-02-07-02-002	0
	SHEET 3 OF 5	

1.0 REFERENCE AND STANDARD DOCUMENTS

11-0269-02-07-02-001	Polyethylene pipes for underground networks for natural gas distribution - General requirements.
11-0269-02-07-02-003	Polyethylene pipes for underground networks for natural gas distribution -Quality control of pipes.
11-0269-02-07-02-007	Supplementary procedure for type-approval of polyethylene pipes for underground networks for natural gas distribution.
IS 14885	Polyethylene Pipes for the Supply of Gaseous Fuels-Specification

Dn	en	SDR	Coil Length in metres	Approved Material	Weight/m (Kg/m)	
20	3	11	200	E3-N3-F3-D1-H3	0.162	
32	3	11	200	E3-N3-F3-D1-H3	0.28	
63	5.8	11	100	E3-N3-F3-D1-H3	1.05	
125	7.4	17.0	50	60	E3-N3-F3-D1-H3	3.5

(*) approximative value according to DIN 8074

Manufacturer	Commercial brand name	Code (*)
--------------	-----------------------	----------

POLYETHYLENE PIPES FOR
UNDERGROUND NETWORKS FOR
NATURAL GAS DISTRIBUTION
TECHNICAL DATASHEET

DOCUMENT NO.

REV

11-0269-02-07-02-002

0

SOLVAY	ELTEX	TUB 121/125	E3
BOREALIS		HE 2490	N3
FINA	FINATHENE	XS10B	F3
DOW		BG1005O	DI
ELENAC	HOSTALEN	CRP 100	H7

	POLYETHYLENE PIPES FOR UNDERGROUND NETWORKS FOR NATURAL GAS DISTRIBUTION TECHNICAL DATASHEET	DOCUMENT NO.	REV
		11-0269-02-07-02-002	0
		SHEET 6 OF 5	

	AAVANTIKA GAS LIMITED CITY GAS DISTRIBUTION PROJECT	
--	--	---

POLYETHYLENE PIPES FOR UNDERGROUND NETWORKS FOR NATURAL GAS DISTRIBUTION - QUALITY CONTROL OF PIPES	CLIENT JOB NO.	-
	TOTAL SHEETS	19

DOCUMENT NO	11	0269	02	07	02	003
--------------------	----	------	----	----	----	-----

--	--	--	--	--	--

0	18.10.09	ISSUED FOR CLIENT COMMENTS	AP	SB	SB
A	16.10.09	ISSUED FOR IDC	AP	SB	SB
REV	DATE	DESCRIPTION	PREP	CHK	APPR

**POLYETHYLENE PIPES FOR UNDERGROUND NETWORKS FOR NATURAL GAS DISTRIBUTION
QUALITY CONTROL OF PIPES**

	POLYETHYLENE PIPES FOR UNDERGROUND NETWORKS FOR NATURAL GAS DISTRIBUTION QUALITY CONTROL OF PIPES	DOCUMENT NO.	Rev
		11-0269-02-07-02-003	0
		Page 2 of 19	

TABLE OF CONTENTS

1.0 SUBJECT AND AREA OF APPLICATION.....4

2.0 REFERENCE AND STANDARD DOCUMENTS 4

3.0 GENERAL PRINCIPLES.....4

4.0 TESTS.....4

APPENDIX 1 – TABLES OF SAMPLES.....9

APPENDIX 2- DIMENSIONAL REQUIREMENTS..... 11

APPENDIX – 3 (FACTORY CERTIFICATE)..... 12

ANNEXURE- 4..... 14

APPENDIX - 5 15

 1.0 PREAMBLE..... 15

 2.0 DESCRIPTION OF MAIN APPEARANCE DEFECTS 15

 3.0 ASSESSMENT CRITERIA..... 17

 4.0 ACCEPTANCE CRITERIA FOR BATCHES 18

	POLYETHYLENE PIPES FOR UNDERGROUND NETWORKS FOR NATURAL GAS DISTRIBUTION QUALITY CONTROL OF PIPES	DOCUMENT NO.	Rev
		11-0269-02-07-02-003	0
		Page 3 of 19	

1.0 SUBJECT AND AREA OF APPLICATION

The purpose of this document is to define the test requirements to be met by PE pipes in accordance with the latest version of the WGI specification listed on reference documents 11-0269-02-07-02-001, - 002, -007

2.0 REFERENCE AND STANDARD DOCUMENTS

11-0269-02-07-02-001 Polyethylene pipes for underground networks for natural gas distribution - General requirements.

11-0269-02-07-02-002 Polyethylene pipes for underground networks for natural gas distribution - Technical data sheet.

11-0269-02-07-02-007 Supplementary procedure for type-approval of polyethylene pipes for underground networks for natural gas distribution.

IS 14885 Polyethylene Pipes for the Supply of Gaseous Fuels-Specification.

3.0 GENERAL PRINCIPLES

3.1. MANUFACTURER'S RESPONSIBILITY

The manufacturer is totally responsible for the quality of the pipes which he manufactures. Acceptance Test procedures do not absolve him from this responsibility.

In order to ensure that the pipes comply with the specification in every case, tie pipes are tested by the factory control department, which is separate from its production department.

The pipes supplied are guaranteed for one year after commissioning or three years maximum after the date of manufacture.

3.2. QUALITY ASSURANCE

The manufacturer must have a quality assurance system in place as described in standard EN 26901 or EN 26902. The quality manual must be supplied to the Owner/ owner representative Quality Control Department.

The quality assurance system shall be certified by an accredited body.

3.3. SPECIMEN SAMPLE OF GRANULATE

The manufacturer shall supply the Owner/ owner representative Quality Control Department with a kilo of granulate from each batch of material used to manufacture the pipes.

The specimen sample is taken in the presence of the Owner/ owner representative Quality Control Department official if testing takes place during manufacture. A suitable container shall be supplied to the manufacturer by Owner.

All necessary precautions shall be taken to prevent contamination and deterioration of the granulate during sampling and during subsequent handling of the sample.

4.0 TESTS

4.1. TESTS CARRIED OUT BY THE MANUFACTURER



POLYETHYLENE PIPES FOR
UNDERGROUND NETWORKS FOR
NATURAL GAS DISTRIBUTION
QUALITY CONTROL OF PIPES

DOCUMENT NO.

11-0269-02-07-02-003

Rev

0

Page 4 of 19

4.1.1. General

It is essential to comply with the provisions in the following sections to ensure that the pipes conform to the specification in every case.

All the pipes are individually numbered. This marking is done using an inert product which will not adulterate the quality of the pipes (e.g. lithographic chalk). The pipe number consists of a maximum of three digits. In the case of pipes with a diameter of 90 mm or more, the number is marked on the inside. For rolled pipes and pipes on drums, it is applied on an adjoining label and the marking must not be subject to deterioration.

4.1.2. Individual tests

4.1.2.1. Appearance

The external and internal appearance of each pipe is checked in accordance with the document, "Assessment of appearance defects on the internal and external surfaces of polyethylene pipes for underground networks for natural gas distribution" (see Appendix 5). A suitable artificial lighting system is used to check the internal appearance.

4.1.2.2. Dimensions

The thickness and average diameter (see Appendix 2), measured in the conditions defined in the specification, are entered in an inspection document which includes the dates of manufacture and the production team, extruder number, code of the material used, pipe number and, if a pipe is declared invalid, the reason for the rejection.

When the manufacturer carries out continuous measurement of the thickness, the record of the values measured shall include all the details necessary for marking of the pipes.

The, inspection documents and any records shall be supplied to the Owner/ owner representative official.

4.1.3. Each batch of material

The pipe manufacturer shall ask the raw material manufacturer for a certificate showing:

- melt mass-flow rate;
- water content;
- density;
- carbon black content;
- carbon black quality;
- thermal stability.

The pipe manufacturer shall carry out the following checks and tests on each batch of material:

- melt mass-flow rate on resin before use;
- volatile and water content;
- thermal stability of the resin.

	POLYETHYLENE PIPES FOR UNDERGROUND NETWORKS FOR NATURAL GAS DISTRIBUTION QUALITY CONTROL OF PIPES	DOCUMENT NO.	Rev
		11-0269-02-07-02-003	0
		Page 5 of 19	

These checks and tests shall be carried out in the conditions laid down in technical specification 11-0269-02-07-02-001

The results are entered in documents showing full identification of the batch of pipe, to be supplied to the Owner/ owner representative official.

4.1.4. Each batch of pipes

For each batch of pipes, the manufacturer shall carry out the following checks and tests in addition to the above-mentioned individual tests:

- ovalisation;
- length;
- melt mass-flow rate on pipe;
- thermal stability of pipe;
- internal stresses;
- resistance to internal hydraulic pressure at 20°C and 80°C;
- determination of traction characteristics of pipes; tension at yield point at 23°C and elongation to fracture at 23°C;
- end-to-end weldability for pipes with diameters of 110 mm or more.

These checks and tests are carried out in the conditions defined in technical specification 11-0269-02-07-02-001

The results are entered in documents showing full identification of the batch of pipes and supplied to Owner/ owner representative.

4.1.5. Type-approval of pipes

When a new material aid/or a new extruder is used, the manufacturer must have the product type-approved in accordance with the 011-269-02-07-02-007 type-approval procedure.

4.1.6. Special tests

- Resistance to atmospheric influence.
- Resistance to growth of cleavage fractures.
- Resistance to slow cracking (notch test).

If necessary, these tests shall be carried out by mutual agreement in an independent laboratory.

4.2 FACTORY ACCEPTANCE BY OWNER/ OWNER REPRESENTATIVE QUALITY CONTROL DEPARTMENT OFFICIAL

4.2.1. General

Acceptance tests are carried out in the presence of an official from the Owner/ owner representative Quality Control Department.

	POLYETHYLENE PIPES FOR UNDERGROUND NETWORKS FOR NATURAL GAS DISTRIBUTION QUALITY CONTROL OF PIPES	DOCUMENT NO.	Rev
		11-0269-02-07-02-003	0
		Page 6 of 19	

All checks and tests are carried out in the conditions laid down in technical specification 11-0269-02-07-02-001

The results must be in accordance with the provisions specified therein and with the individual specifications of the order.

On each visit, the manufacturer provides the Owner/Owner's representative free of charge with the facilities and personnel necessary to carry out the tests laid down in the specification. In addition, during execution of the order, the Owner/Owner's representative has access to the storage installations for the raw materials before manufacture, the manufacturing and testing installations and the storage areas for the pipes for which Owner/Owner's representative is responsible for testing.

On arrival at the factory for his inspection, Owner/Owner's representative receives a certificate for each batch of pipes presented for acceptance. This document shall be consistent with the specimen in Appendix 3.

In addition, when acceptance relates to part of an order, the supplier must provide the Owner/Owner's representative with a stock list and a history of the stock of pipes intended for CONSULTANT. A specimen of this form is attached to this document: Appendix 4.

Whenever so requested by the Owner/Owner's representative, the manufacturer must be able to provide him with recent test and calibration reports for the measuring instruments and test installations.

4.2.2. Convening notice for acceptance

The acceptance convening procedures are specified in the order.

4.2.3. Acceptance tests

4.3.2.1. Appearance, dimensions and marking

The number of pipes examined is at least 10 % of the pipes presented for acceptance.

The pipes to be examined are placed on work trestles or grids for ease of testing.

Rolled pipes are presented on reels.

4.3.2.2. Checking of characteristics

For each batch of pipes as defined in technical specification 11-0269-02-07-02-001 or a constituent part thereof, the minimum samples to be taken are stated in the table in Appendix 1.

4.3 ACCEPTANCE AND REJECTION

4.3.1. Appearance, dimensions and marking

Any failure means that the batch is rejected. It may however be presented again after sorting, with the agreement of the Owner/Owner's Consultant.

4.3.2 Checking of characteristics

Any result which is not in accordance with the provisions of the specification and the individual specifications of the order shall give rise to a repeat test on at least double the number of samples. If the unfavorable result is confirmed, the batch is definitively rejected. If the unfavorable result is invalidated, the batch is accepted.

	POLYETHYLENE PIPES FOR UNDERGROUND NETWORKS FOR NATURAL GAS DISTRIBUTION QUALITY CONTROL OF PIPES	DOCUMENT NO.	Rev
		11-0269-02-07-02-003	0
		Page 7 of 19	

By way of additional investigation, other analyses or examinations may be carried out by mutual agreement, at the manufacturer's expense.

4.4 DISPATCH WITHOUT ACCEPTANCE

If Owner/Owner's representative decide to waive the acceptance procedures, it reserves the right to ask the manufacturer to carry out the acceptance tests and checks laid down in 4.2.3.

The supplier is obliged to send the Owner/Owner's representative a factory certificate, the stock lists and the acceptance test and check report if these have been requested.

These documents shall contain the order references.

Failure to observe the above procedures shall be sanctioned by refusal to take delivery.

	POLYETHYLENE PIPES FOR UNDERGROUND NETWORKS FOR NATURAL GAS DISTRIBUTION QUALITY CONTROL OF PIPES	DOCUMENT NO.	Rev
		11-0269-02-07-02-003	0
		Page 8 of 19	

APPENDIX 1 – TABLES OF SAMPLES

Test	Quality criterion as per specification G001-1	Test method As per Specifications G001-1	No of samples per batch	Number of test specimens
Internal stresses	§ 5.2.2.1	§ 6.8	2	3 from the same pipe
Determination of traction characteristics	§ 5.2.2.5	§ 6.12	2	3 from the same pipe
Melt mass flow rate	§ 5.2.1.4	§ 6.3	2	1 from Same pipe
Resistance to internal hydraulic Pressure -at 20 ⁰ C	§ 5.2.2.2	§ 6.9	1	2 test specimen(+2 reserves)(1) 1 test specimen per pipe
-at 80 ⁰ C			1	2 test specimen(+2 reserves)(1) 1 test specimen per pipe
Weldability	§ 5.2.2.6	§ 6.13	2(4)	2 section of different pipe welded end to end
Traction on welded pipe	§ 5.2.2.2	§ 6.9	1	1 welded sample(3)
Resistance to internal hydraulic pressure -at 20 ⁰ C			1	See note (2)
-at 80 ⁰ C			1	See note (2)
Resistance to slow cracking of notched pipe (Notch test)	§ 5.2.2.3.	§ 6.10	4(3)	See note (5)

POLYETHYLENE PIPES FOR
UNDERGROUND NETWORKS FOR
NATURAL GAS DISTRIBUTION
QUALITY CONTROL OF PIPES

DOCUMENT NO.

Rev

11-0269-02-07-02-003

0

Page 9 of 19

Resistance to growth of cleavage fractures	§ 5.2.2.4.	§ 6.11	4(3)	See note (5)	
Thermal stability of PE	§ 5.2.1.7.	§ 6.6	1(3)	See note (5)	

Notes

- (1) Number of test specimens to be tested: 1 specimen at start of manufacture and 1 specimen at end of manufacture per shift basis.
- (2) In agreement with the Owner official, these tests on welded test specimens may be included in the series of tests designed to check resistance to internal hydraulic pressure.
- (3) Performance of this test is left to the discretion of the Owner/Owner's Representative.
- (4) The number of welded samples per batch may be increased to three if the Owner official has decided to carry out the traction test on the welded sample.
- (5) The taking of samples is left to the discretion of the Owner official, if the manufacturer is not equipped to carry out these tests properly, they shall be carried out at the manufacturer's expense in a reputed laboratory chosen by Owner.

	POLYETHYLENE PIPES FOR UNDERGROUND NETWORKS FOR NATURAL GAS DISTRIBUTION QUALITY CONTROL OF PIPES	DOCUMENT NO.	Rev
		11-0269-02-07-02-003	0
		Page 10 of 19	

APPENDIX 2- DIMENSIONAL REQUIREMENTS

The pipes belong to either series SDR 11 or SDR 17 defined below:

THICKNESS

Nominal Diameter de	SDR 11			SDR17		
	en	emin in mm	emax in mm	en	emin in mm	emax in mm
20	3	3	3.4	-	-	-
32	3	3	3.5	2.3	2.3	-
63	5.8	5.8	6.6	3.8	3.8	-
125	11.4	11.4	-	7.4	7.4	8.0
180	16.4	16.4	-	10.7	10.7	11.5

MEAN EXTERNAL DIMENSIONS

Nominal Diameter de	MEAN EXTERNAL DIAMETER dm	
	dm min. in mm	dm max in mm
20	20	20.3
32	32	32.3
63	63	63.4
125	125	125.8
180	180	181.1

POLYETHYLENE PIPES FOR UNDERGROUND NETWORKS FOR NATURAL GAS DISTRIBUTION QUALITY CONTROL OF PIPES	DOCUMENT NO.	Rev
	11-0269-02-07-02-003	0
	Page 11 of 19	

APPENDIX – 3 (FACTORY CERTIFICATE)

APPENDIX 3 - FACTORY CERTIFICATE

PE pipes for underground gas networks		FACTORY CERTIFICATE n°	
Supplier:		Order :	
Dimensions:		SDR Series:	
Material:	Batch no:	Date of manufacture:	
MRS:			
1. TEST ON MATERIAL			
1.1 MFI :		g/10 min	
1.2 Volatile content :		mg/kg	
1.3 Thermal stability :		min	
2. PRODUCTION TEST ON EXTRUDED PIPES			
2.1 Dimensions	d _e min:	d min:	e _h max:
	d _e max:	d max:	e _h min:
2.2 Surface appearance	Smooth pipes free of cavities, pitting, scratches or other defects:		Checked:
2.3 Traction:	Elongation to fracture:		
2.4 Internal stresses:			
2.5 Weldability:			
2.6 Hydraulic tests:	80 °C - or Minn ² :	20 °C - or Minn ² :	hr
	g/10 min	hr	
2.7 MFI:			
2.8 Thermal stability:		min	
2.9 Volatile contents:		mg/kg	
3. Marking of pipes			
4.	Packing	Number	Unit length
	Crates		
	Rolls		
	Drums		
Date	Factory stamp		Signature

C	Available before acceptance (A - Σ B)											Call no.	Destination		
Presented for acceptance															
D	Accepted														
E	Stock after acceptance (C + D)														
F	Balance on calls recorded														
	1														
2															
3															
4															
5															
6															
7															
8															
9															
10															
G	Available (E - Σ F)										Comments:				
H	Stock not accepted														
I	In production														
Stock still available to cover 1 month's consumption (G + H + I)															
Date:					Factory stamp										
Name:															
Signature:															

(†) delete as applicable

ANNEXURE- 4

Stock list		PE pipes for natural gas distribution networks- STS G001-3				Sheet n°		
Order n°		Acceptance/Authorisation (1) dated:				Material:		
m)		Ø = 110		Ø = 160	Ø = 200	Ø =	R = Rolls	
		R490	L14	L14	L14		L = Straight length	
	SDR	17,6	17,8	17,6	17,6			
A	Stock available after acceptance n° dated							
B	Deliveries						Call no.	Destination
1								
2								
3								
4								
5								
6								
7								
8								
9								
10								
C	Available before acceptance (A-Σ B)							
	Presented for acceptance							
D	Accepted							
E	Stock after acceptance (C + D)							
F	Balance on calls recorded						Call no.	Destination
1								
2								
3								
4								
5								
6								
7								
8								
9								
10								
G	Available (E - E F)						Comments:	
H	Stock not accepted							
I	In production							
	Stock still available to cover 1 month's consumption (G + H + I)							
Date:					Factory stamp			
Name:								
Signature:								

(1) Delete as applicable

APPENDIX - 5

**ASSESSMENT OF APPEARANCE DEFECTS ON INTERNAL AND EXTERNAL SURFACES
OF POLYETHYLENE PIPES FOR UNDERGROUND
NETWORKS FOR NATURAL GAS DISTRIBUTION**

1.0 PREAMBLE

The internal and external surfaces of the tubes are examined visually with the naked eye, without magnification and under adequate lighting.

2.0 DESCRIPTION OF MAIN APPEARANCE DEFECTS

2.1. DEFECTS CAUSED BY HANDLING OR STORAGE

2.1.1. Incrustation with foreign matter

Pebbles, sand, glass, filings, wood splinters, etc.

2.1.2 Scratches

Narrow continuous lesions.

2.1.3 Notches

Incisions made by a sharp instrument.

2.1.4 Superficial wear and tear

Surface deterioration resulting from friction against foreign matter.

2.1.5 Holes

Holes in the wall caused by forceful insertion of a generally pointed object (e.g.: nails, probes, SS screws, etc.).

2.1.6 Dented walls

Permanent distortion of the wall accidentally caused during handling.

2.2 MANUFACTURING DEFECTS¹

2.2.1. Continuous longitudinal internal lines

Longitudinal marks evenly distributed around the inner circumference of the pipe, caused by fusion of material faces on exit from the extrusion tool. These marks are caused by an incorrect choice of transformation parameters.

2.2.2. Continuous longitudinal lines inside and outside

These do not exceed 0.20 mm in depth.

- They may be caused by the defective condition of the calibrators or the sealing device for the calibration system, in which case they are isolated instances.

- They may be caused by friction of residual deposits attached to parts of the extrusion tool, the calibrators or the sealing plug of the calibration system. In this case, they are generally randomly

	POLYETHYLENE PIPES FOR UNDERGROUND NETWORKS FOR NATURAL GAS DISTRIBUTION QUALITY CONTROL OF PIPES	DOCUMENT NO.	Rev
		11-0269-02-07-02-003	0
		Page 15 of 19	

distributed.

These deposits may consist of waxes, oxidised polyethylene or other products which are released during transformation of the material in the extruder or which are present in the cooling water.

2.2.3. Incrustation with residual matter generated during extrusion

The deposits defined in 2.2.2. work loose and are crushed in the external wall of the pipes while passing into the calibrator, or adhere to the internal wall of the pipes.

2.2.4. Presence of foreign matter in the polyethylene resulting from contamination of the raw material .

This contamination may be caused by all sorts of liquid or solid products (oil, paper, cardboard, plastics, glass, sand, dust, etc.).

2.2.5. Excessive water and volatile contents

2.2.5.1. Porosity

Defects generally caused by volatile matter which occur specifically when the water and volatile contents are too high.

¹The term extrusion defect covers all defects resulting from the complete pipe manufacturing process.

2.2.5.2. Craters (surface spalling)

Shallow or deep conical cavities the cause of which is difficult to establish, generally the result of water and volatile contents being too high.

2.2.6 Pitting

Defects in the shape of aligned dots, either in clusters or dispersed, which are often connected with carbon black anomalies.

2.2.7 Unfused parts

Molecular polyethylene elements which are totally or partially unfused and located both on the surface and right inside the thickness of the pipe wall.

2.2.8 Cavities

Superficial denting of the external wall, sometimes replicated on the internal wall.

This is the result of distortion caused by a drop of water between the pipe and the calibrator at the intake. The water comes from the calibrator cooling system and is a common phenomenon if the pressure of the calibrator cooling water is too high.

2.3. DEFECTS CAUSED BY MARKING

2.3.1 Marking too deep

This is caused by incorrect setting of the stamps or the stamp design.

2.3.2 Indentations caused by the tool holding the marking stamps

These are the result of incorrect settings or wear and tear.

	POLYETHYLENE PIPES FOR UNDERGROUND NETWORKS FOR NATURAL GAS DISTRIBUTION QUALITY CONTROL OF PIPES	DOCUMENT NO.	Rev
		11-0269-02-07-02-003	0
		Page 16 of 19	

3.0 ASSESSMENT CRITERIA

3.1. CRITICAL DEFECTS

The following defects are critical:

- Continuous longitudinal internal lines (see § 2.2.1.)
- Presence of foreign matter in the polyethylene resulting from contamination of the raw material (see § 2.2.4.)
- Porosity (see § 2.2.5.1.)

3.2 OTHER DEFECTS

Defects caused by handling or storage

Pipes presenting one of the following defects are classified as defective:

- Incrustation with foreign matter (see § 2.1.1.).
- Scratches (see § 2.1.2.), the depth of which is more than 10% of the thickness, with a limit of 0.5 mm.
- Superficial wear and tear (see § 2.1.4.), where the depth of the marks is more than 10% of the thickness, with a limit of 0.5 mm.
- Notches (see § 2.1.3.), the depth of which is more than 10% of the thickness, with a limit of 0.50 mm.
- Holes, the depth of which (see § 2.1.5.) is more than 10% of the thickness, with a limit of 0.50 mm
- Dents in the pipe wall (see § 2.1.6.).

3.2.2 Manufacturing defects

3.2.2.1 Incrustation with residual matter generated during extrusion, craters, pits, unfused elements (see § 2.2.3., 2.2.5.2., 2.2.6. and 2.2.7.)

A sample may present several of the above defects.

Let p be the depth of the defect and e the nominal thickness of the pipe.

Case 1 : $p > 0.1.e$

Any pipe which includes one of the above defects where the depth is more than 10% of the nominal thickness of the pipe is always considered to be defective.

Case 2 : $p \leq 0.1.e$

For a pipe which contains isolated defects², the depth of which is 10% of the nominal thickness or less, each defect is allocated a grade g depending on its largest dimension a , excluding the depth. The value of g in terms of a is defined in Table 1.

	POLYETHYLENE PIPES FOR UNDERGROUND NETWORKS FOR NATURAL GAS DISTRIBUTION QUALITY CONTROL OF PIPES	DOCUMENT NO.	Rev
		11-0269-02-07-02-003	0
		Page 17 of 19	

Table I

Largest dimension a of defects in mm	Grade
1.0≤a<2.0	5
2.0≤a <3.0	10
3.0≤a<4.0	25
4.0≤a<5.0	50
5.0≤a<6.0	51

Defects, the largest dimension of which is less than 1mm are not taken into account.

A pipe is considered to be defective when it presents a defect, the largest dimension of which is 6.0 mm or more.

A pipe is considered to be defective when the sum of the products of the grades g multiplied by the number of defects n detected along a length of 100 cm exceeds the value L defined in table 2 in terms of the diameter of the pipe.

Table 2

Nominal diameter de	$L=\sum(n.g)$
20	20
32	20
63	40
125	40

3.2.2.2 Continuous longitudinal marks inside and outside, cavities, marking too deep and indentations caused by marking tool.

Pipes presenting the following defects are classified as defective:

- Continuous longitudinal marks on the inside and outside which are 0.20 mm deep or more (see § 2.2.2.).
- Cavities (see § 2.2.8.).
- Marking too deep (see § 2.3.1.), where the depth is more than 0.20 mm.
- Indentations caused by the marking tool (see § 2.3.2.), where the depth is more than 0.20 mm.

4.0 ACCEPTANCE CRITERIA FOR BATCHES

4.1. CRITICAL DEFECTS

When a pipe presents one of the defects described in section 3.1., the batch is rejected.

² A defect is considered to be isolated if the gap between the closest edges of two defects is greater than the largest dimension of the defects. Otherwise, it is a single case defect.

Note: Porosity

Rejection is confirmed if the water or volatile contents measured exceed the criteria laid down in the technical specification.

	POLYETHYLENE PIPES FOR UNDERGROUND NETWORKS FOR NATURAL GAS DISTRIBUTION QUALITY CONTROL OF PIPES	DOCUMENT NO.	Rev
		11-0269-02-07-02-003	0
		Page 18 of 19	

4.2 OTHER DEFECTS

The following rules apply to the sampling test³.

When examining the pipes comprising the sample batch, let n_1 be the number of defective pipes or rolls

if $n_1=0$ the batch is acceptable;

if $1 \leq n_1 < 3$ the batch is acceptable, but the defective pipes or rolls are eliminated; if

$n_1 \geq 3$ a second sample is taken from the batch presented following the procedures described previously, and the defective pipes or rolls are eliminated.

Sampling: The sample comprises the pipes contained in a whole number of packaging units (crates or rolls) corresponding to 10% in excess of the total length of pipes presented. Examination of the appearance covers the surfaces of the internal and external walls. In the case of pipes rolled on a drum, the appearance is checked for each drum on the sections of pipes in the last layer of rolled coils, as well as those accessible from the side.

When examining the pipes comprising the second sampling, let n_2 be the number of defective pipes or rolls

if $n_2 = 0$ the batch is acceptable;

if $1 \leq n_2 < 3$ the defective pipes or rolls are eliminated;

if $n_2 \geq 3$ the batch is rejected. It may be sorted and, if necessary, the balance of the sorting operation may be presented again for testing.

	POLYETHYLENE PIPES FOR UNDERGROUND NETWORKS FOR NATURAL GAS DISTRIBUTION QUALITY CONTROL OF PIPES	DOCUMENT NO.	Rev
		11-0269-02-07-02-003	0
		Page 19 of 19	

AAVANTIKA GAS LIMITED
CITY GAS DISTRIBUTION PROJECT



PE ACCESSORIES FOR UNDERGROUND NETWORKS FOR NATURAL GAS DISTRIBUTION					CLIENT JOB NO.	-
					TOTAL SHEETS	20
DOCUMENT NO	11	0269	02	07	02	004

<p style="font-size: 2em; margin: 0;"> </p>					
---	--	--	--	--	--

0	18.10.09	ISSUED FOR CLIENT COMMENTS	AP	SB	SB
A	16.10.09	ISSUED FOR IDC	AP	SB	SB
REV	DATE	DESCRIPTION	PREP	CHK	APPR

**PE ACCESSORIES FOR UNDERGROUND NETWORKS FOR NATURAL GAS
DISTRIBUTION**

	PE ACCESSORIES FOR UNDERGROUND NETWORKS FOR NATURAL GAS DISTRIBUTION	DOCUMENT NO.	Rev
		11-0269-02-07-02-004	0
		Page 2 of 20	

TABLE OF CONTENTS

1.0 SUBJECT AND AREA OF APPLICATION..... 4

2.0 REFERENCE STANDARDS AND SPECIFICATIONS 4

3.0 DEFINITIONS 5

4.0 GENERAL SPECIFICATIONS 7

5.0 MATERIALS..... 7

6.0 GENERAL ACCESSORY CHARACTERISTICS..... 8

7.0 GEOMETRICAL CHARACTERISTICS11

8.0 ACCESSORY MECHANICAL CHARACTERISTICS15

9.0 PHYSICAL CHARACTERISTICS15

10.0 PRODUCT APPROVAL15

11.0 MARKING15

12.0 PACKAGING AND DELIVERY16

13.0 QUALITY CONTROL16

ANNEXURE - 1.....19

	PE ACCESSORIES FOR UNDERGROUND NETWORKS FOR NATURAL GAS DISTRIBUTION	DOCUMENT NO.	Rev
		11-0269-02-07-02-004	0
		Page 3 of 20	

The information contained in this document should be treated as confidential and is to be considered as the exclusive property of WGI

Direct or indirect use of this document or any part of it is only allowed for WGI productions.

1.0 SUBJECT AND AREA OF APPLICATION

This specification has been established to define the requirements that must be met by injected moulded polyethylene accessories (PE) destined for the construction or the maintenance of underground networks for natural gas distribution where the maximum operating pressure (MOP) is equal to 6 bars.

It also defines some of the more general characteristics of materials used for accessory manufacturing and includes the appropriate classification model.

The specification also includes testing method parameters for the material in question.

All accessories included in these specifications are listed as follows:

- Electrofusion welded accessories
- Electrofusion welded saddles
- Accessories equipped with insertion connection for end to end welding and assembly using electrofusion-welded sleeve coupling.

This specification is limited to accessories with a nominal diameter of 225 mm and a working temperature between 0°C and +50°C.

PE and steel accessories with a tapered section and front section connections are not included in these specifications.

2.0 REFERENCE STANDARDS AND SPECIFICATIONS

EN 682	Air-tight rubber seals - specification for air-tight seal materials for gas and hydrocarbon fluid transfer piping
EN 1555-1	Plastic piping systems for combustible gas distribution. Polyethylene (PE). Part 1. General information

	PE ACCESSORIES FOR UNDERGROUND NETWORKS FOR NATURAL GAS DISTRIBUTION	DOCUMENT NO.	Rev
		11-0269-02-07-02-004	0
		Page 4 of 20	

- EN 1555-3 Plastic piping systems for combustible gas distribution. Polyethylene (PE). Part 3 .
Accessories
- EN 1555-7 Plastic piping systems for combustible gas distribution. Polyethylene (PE). Part 7.
Conformity evaluation.
- ISO DIS 11413 Preparation of test assemblies between a polyethylene (PE) pipe and an electrofusion fitting.
- ISO DIS 11414 Preparation of test assemblies between a pipe/pipe or pipe/fitting polyethylene (PE) by butt fusion
- ISO DIS 12093 Format for a technical brochure for electrofusion joint characteristics.
- ISO TR 13950 Electrofusion identification methods
- CEI 60335-1 Safety standards for household appliances and similar equipment.
- CEI 364 Electrical installations on buildings (including building sites and other temporary installations)
- CEI 449 Voltage domains for building electrical installations.
- ISO 14885:2022 Polyethylene pipes for the supply of Gaseous Fuels-Specifications.
- 11-0269-02-07-02-001 to 11-0269-02-07-02-003
WGI technical specification: polyethylene piping for underground networks for natural gas distribution
- 11-0269-02-07-02-005 WGI technical specification: raw materials for manufacturing piping and accessories for underground networks for natural gas distribution.
- 11-0269-02-07-02-006 WGI specification sheets: program execution. Polyethylene pipe laying.

3.0 DEFINITIONS

3.1. ELECTROFUSION ACCESSORY

This term covers all injected moulded polyethylene accessories equipped with a heated element designed to transform electrical energy into heat to create self-welding.

	PE ACCESSORIES FOR UNDERGROUND NETWORKS FOR NATURAL GAS DISTRIBUTION	DOCUMENT NO.	Rev
		11-0269-02-07-02-004	0
		Page 5 of 20	

In certain exceptional cases, an accessory can present one or more smooth ends. In this case the accessory will provide for the requirements of each connection end as regards shape, measurement, and technical characteristics.

3.2. ELECTROFUSION SADDLE

This term covers a saddle shaped injection moulded PE accessory that is equipped with one or several heating elements that convert electrical energy into heat. The released heat provides a fusion surface sufficiently large to ensure correct saddle-pipe assembly.

Electrofusion saddles can be subdivided into two categories:

Wrap around: Electrofusion saddle whose upper shell is brought against the pipe during welding using a fastening stirrup located on the lower part of the accessory to guarantee that the welding pressure is sufficient. Generally the stirrup is left in place after welding.

Top load: Electrofusion saddle where the welding pressure is obtained by pressing down on the saddle head using a fixing system (clamp) that is removed after welding is completed.

There are four different saddle types:

Support This is an accessory designed for joining branch pipes and is equipped with a drill bit made to pierce the wall of the pipe; this bit remains in the saddle body after installation.

Branch piping This accessory is designed for joining branch piping where an saddle additional bit is necessary to pierce the wall of the main pipe next to the branch.

Ballooning This accessory provides the positioning of a sealing (or blocking) saddle balloon and that can be filled again after work completion.

Repair saddle This accessory will seal/block any leaks on the pipe or will reinforce piping in the case of localised deterioration.

According to their leakage flow, the supports are divided into two model categories:

Model-1	Supports whose maximum immediate leak flow is practically zero at 5 bar pressure in the piping.
Model-2	supports whose maximum immediate external leak flow never exceed 200 litres an hour at 5 bar pressure in the piping.

3.3 END TO END WELDING ACCESSORIES

This term describes injection moulded polyethylene accessories with smooth ends but not equipped with integrated heating elements. These are connected to the network by end-to-end welding using electrofusion sleeves.

In certain exceptional cases, an accessory can also present one or more electrofusion ends. In this case the accessory will provide for the requirements of each connection end in shape, measurement, and technical characteristics.

4.0 GENERAL SPECIFICATIONS

This specification is based on the series of EN 1555 standards, which standardize all the gas distribution network plastic piping systems.

The accessories described in this document comply with all prescriptions included in EN standard 1555-3, as well as all complementary requirements and/or options described in these WGI specifications. The accessories are destined for use in gas distribution networks in piping in compliance with WGI specification 11-0269-02-07-02-001to 11-0269-02-07-02-003

The pipes are laid and welded as described in our specification sheet for pipe laying 11-0269-02-07-02-006.

5.0 MATERIALS

5.1. GENERAL INFORMATION

The materials used for the manufacturing of the accessories must conform to the requirements demanded for components used in gas fuel distribution networks. All fittings shall be electrofusion fittings only. Fusion fittings shall have inbuilt positioning provision upto 60mm and beyond external clamp system. The wall thickness of the fittings shall be more or equal to the wall thickness of the pipe jointed.

The accessory material that is in contact with the PE piping must not be composed of any material that will provoke a reduction in pipe performance, nor must it provoke cracking under stress.

All equipment shall be marked with inscription/description and specification in English language

5.2. RAW MATERIAL SPECIFICATIONS

The raw material PE, used for accessory production, shall be in compliance with all prescriptions in EN 1555-1 standards. It must be approved according to the prescriptions in WGI specification 11- 0269-02-07-02-005.

The raw material shall be class PE100.

	PE ACCESSORIES FOR UNDERGROUND NETWORKS FOR NATURAL GAS DISTRIBUTION	DOCUMENT NO.	Rev
		11-0269-02-07-02-004	0
		Page 7 of 20	

The following are strictly forbidden:

- use of recycled raw materials
- mixing of different raw materials
- the addition of supplementary additives to the raw material.

5.3. SPECIFICATIONS FOR COMPONENTS MADE OF MATERIALS OTHER THAN POLYETHYLENE

5.3.1. Metal parts

All metal parts subject to corrosion must be protected in an adequate manner.

Metal parts must conform to prescribed standards of that particular material for gas distribution, for quality levels, size/gauge and measurements.

Cast iron, aluminium and its alloys are not authorized for use.

- Elastomers

Elastomer air and watertight seals, like all other elements manufactured in this material, must comply with the prescriptions of EN 682 standards.

- Other materials

All other materials used are in compliance with the prescriptions described in paragraph 5.1. The accessories included in the paragraph comply with the requirements of this specification and are adapted for all general use for natural gas distribution.

6.0 GENERAL ACCESSORY CHARACTERISTICS

6.1 TECHNICAL INFORMATION

The manufacturer must supply a technical information dossier composed and including the same material and presented in the same manner, in compliance with the prescriptions of the ISO DIS standard I2O93. This dossier must mention all of the following information for each accessory:

- PE raw material used
- Measurements and tolerances
- Domain of application (temperature and pressure limits, SDR and ovalisation)
- Assembly instructions
- Welding instructions (welding parameters and limits)
- Test results attesting to the accessory conformity standard: c.f. EN standard 1555-3 for test descriptions.

	PE ACCESSORIES FOR UNDERGROUND NETWORKS FOR NATURAL GAS DISTRIBUTION	DOCUMENT NO.	Rev
		11-0269-02-07-02-004	0
		Page 8 of 20	

For electrofusion accessories, the manufacturer must also supply the SDR series for the pipes, which will be used together with their accessory, according to their thickness. In addition, for the saddles:

- The attaching method (tools necessary and/or lower shell)
- saddle category (refer to 3.2)
- Maximum saddle height (H in figure 2)
- the height of the branch pipe for supports (h in figure 2)

For all smooth ended accessories, the manufacturer must also supply the SDR series of connections; the accessory must be guaranteed for use on piping of the same class.

In the case of welding parameter modification, size or raw material changes. The manufacturer must include a new technical dossier providing proof that the accessory in question is still compliant with the specification prescriptions.

Testing assemblies will take into consideration manufacturing tolerance, assembly tolerance and the variations in environmental temperature corresponding with the conditions where the accessories will be in use. The manufacturer must observe all methods recommended for polyethylene accessory installation as shown in the WGI specifications.

The accessories will be tested exclusively using piping in compliance with WGI specifications concerning PE piping (11-0269-02-07-02-001 to 11-0269-02-07-02-003).

The assembly of piping and accessories manufactured and used in the tests must be in compliance with the manufacturer's technical instructions and the limits of use conditions. When the test assemblies are carried out, the manufacturing and assembly tolerances must be taken into consideration. Samples destined for assembly testing with electrofusion accessories must be prepared according to standard ISO DIS 11413. End- to-end welded samples must be prepared according to standard ISO DIS 11414.

6.2. APPEARANCE AND FINISH

The internal and external surfaces of the accessories must be smooth, clean and free of all scratching, pitting and other surface faults that can possibly reduce accessory and assembly performance.

No element of any accessory must show any signs of damage: scratching, scraping, piercing, blisters, bloating, denting, holes, cracks or other faults that can reduce required performance.

It must be possible to place the accessory on the pipe or on another accessory without moving the electric winding or the air/water tight seals etc. and this must respect the tolerance permitted for piping and accessories.

6.3. COLOUR

All accessories will be black. If agreed previously, they can also be coloured yellow or

orange. 6.4. JOIN APPEARANCE

	PE ACCESSORIES FOR UNDERGROUND NETWORKS FOR NATURAL GAS DISTRIBUTION	DOCUMENT NO.	Rev
		11-0269-02-07-02-004	0
		Page 9 of 20	

After welding, when examined visually without a magnifying glass, the internal and external surfaces of the pipes and accessories must appear free of welding exudation outside the accessory limits (unless identified by the accessory manufacturer as normal, or carried out deliberately as a welding test, but on condition that there is no wiring position change inside the electrofusion accessories that could provoke a short-circuit). Internal surfaces of all adjacent piping must remain identical to the previous condition before welding.

6.5. ELECTROFUSION ACCESSORY ELECTRICAL CHARACTERISTICS

6.5.1. General information

The accessories include an electrical system as described in the standards CENELEC 60335-1, CEI 364 and CEI 449.

This system is equipped with an appropriate electrical protection for the voltage and intensity of the current in use, and adapted to the characteristics of the electrical supply line.

For voltage over 24 V protection is essential against direct contact with the active parts (conductors on line). The type of protection in question depends on the local site conditions.

6.5.2. Classification

Electrofusion accessories are divided into three classes according to the voltage and/or current characteristics.

Class A Electrical supply based on voltage set between 8V and 42 V

Class B Electrical supply based on voltage set between 42 V and 220 V

Class C Electrical supply based on power supply settings.

All supplies, unless otherwise stipulated in the order, concern Class A accessories.

The power required for electrofusion accessory welding must not exceed 3kW during welding operations. Unless stipulated otherwise in the order, only 'wrap-around" saddles can be supplied (refer to par. 3.2.) Unless otherwise agreed between WGI and the supplier, all electrofusion accessories must be "single wire" type.

6.5.3. Connectors

Electrical connectors installed on electrofusion accessories must comply with the diagram included in Annex 1 with these specifications, also including constant current supply where this is the case. The state of the connector terminal surface must offer the minimum possible contact resistance during voltage cable joining.

6.5.4. Protection against overheating

	PE ACCESSORIES FOR UNDERGROUND NETWORKS FOR NATURAL GAS DISTRIBUTION	DOCUMENT NO.	Rev
		11-0269-02-07-02-004	0
		Page 10 of 20	

Electrofusion accessories that can only be welded once are equipped with a lock system which prevents re-welding.

Electrofusion accessories that cannot be re-welded immediately after initial welding are equipped with an incorporated security system in their welding program: that is they cannot weld while the wire is still hot. If the welding program does not possess this lock system, the electrofusion accessory must absolutely be protected against a second or several welding cycles whatever the temperature of the winding wire.

6.5.5. SUPPORT DRILLING EQUIPMENT

The support drilling equipment has been designed so that during drilling the maximum immediate leak flow will never exceed 200 litres per hour at 5 bar pressure, in the main pipe. According to this flow rate, the supports are divided into two categories:- models 1 and 2 (refer to par. 3.2.) The required model will be specified when ordered.

The bell drill is equipped with a maneuvering opening for the insertion of a 17 mm hexagonal spanner. The bell drill path is limited at the top and bottom by a limit block.

The drill mechanism is designed so that no additional tools (except the hexagonal spanner described above) are necessary for carrying out drilling operations.

6.5.6. BRANCHING SUPPORT AND SADDLE LOAD LOSS UNDER LOW PRESSURE

The maximum load loss measured with natural gas at an inlet pressure of 20 mbar must not exceed the values listed below.

Flow m ³ /hr	Saddle Type	Maximum load loss, Mbar
10	32x20	1.0
10	63x20	1.0
10	63x32	1.0
40	125x32	1.0
40	125x63	2.0

6.5.7. ELECTROFUSION SLEEVE BLOCK

All electrofusion sleeves are equipped with an immovable block in the centre of the sleeve.

7.0 GEOMETRICAL CHARACTERISTICS

7.1. SIZE OF ELECTROFUSION SLEEVES

The sizes of the electrofusion accessory sleeves and their tolerance limits are described in chapter "Geometrical characteristics" of EN standard 1555-3.

They are controlled according to the method described in the specification standard. Any possible sealing

	PE ACCESSORIES FOR UNDERGROUND NETWORKS FOR NATURAL GAS DISTRIBUTION	DOCUMENT NO.	Rev
		11-0269-02-07-02-004	0
		Page 11 of 20	

plugs are removed from the sleeve 4 hours before the size control check. Measurements are controlled without the plugs inserted.

The main symbols are shown in the figure 1 below:

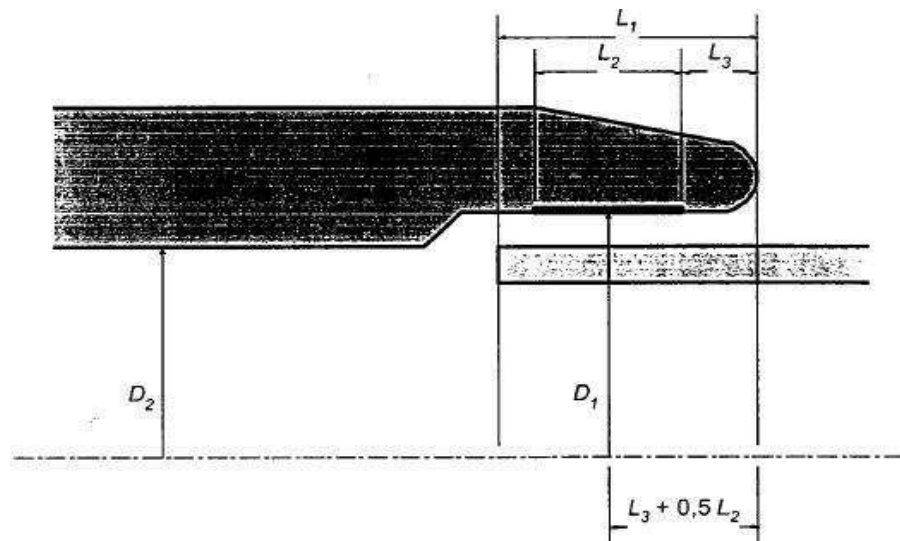

- D1 The “average internal diameter in the welding zone” — that is: the average internal diameter measured in a parallel plane to the opening plane, at a distance of $L_3 + L_2/2$ of the latter.
- D2 “Minimum drilling/boring” — that is the minimum diameter of the draining canal through the body of the accessory.
- L1 “penetration depth” of the pipe or the inserted (male) end of the accessory
- L2 “Nominal length of the welding zone” that corresponds with the length subject to heating.
- L3 “Nominal non-heated entry/inlet length of the sleeve”. This refers to the distance between the tip of the accessory and the beginning of the welding zone.

7.2 ELECTROFUSION SADDLE MEASUREMENTS

The measurements of the electrofusion saddles and their tolerance limits are described in EN standard 1555-3

They are controlled according to the method described in the specification standard. Any possible sealing plugs are removed from the sleeve 4 hours before the size control check. Measurements are controlled without the plugs inserted.

The main symbols are shown in the figure 2 below:

	PE ACCESSORIES FOR UNDERGROUND NETWORKS FOR NATURAL GAS DISTRIBUTION	DOCUMENT NO.	Rev
		11-0269-02-07-02-004	0
		Page 12 of 20	

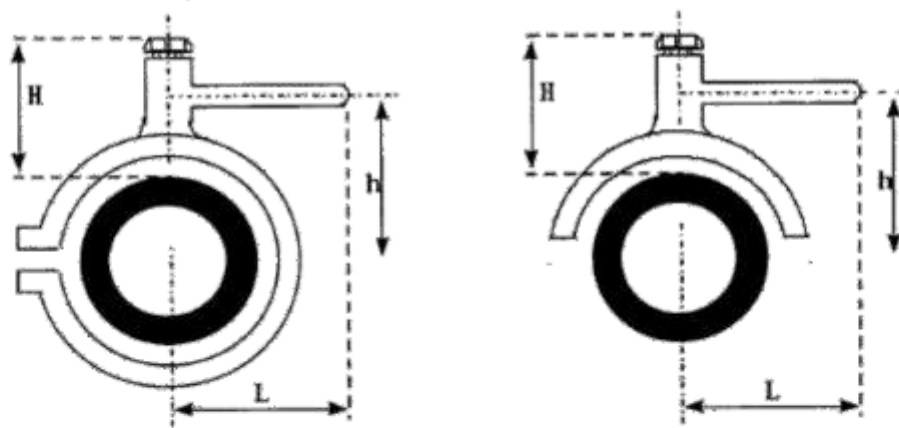

FIG.2

- H The “height of the saddle” — that is the distance between the upper generator of the main pipe and the top of the branch pipe saddle
- h The “height of the branch pipe” — that is the distance between the axis of the main pipe and the axis of the branch pipe
- L The “width of the branch pipe saddle” — that is the distance between the axis of the pipe and the surface plane of the branch pipe opening

7.3. MEASUREMENTS OF ACCESSORY ENDS TO BE WELDED

The measurements of the ends and their tolerance limits are described in EN standard 1555-3.

They are controlled according to the method described in these specification standards. Any possible sealing plugs are removed from the sleeve 4 hours before the size control check. Measurements are controlled without the plugs inserted.

The measurements and main symbols used in this specification are shown in the figure 3 below:

	PE ACCESSORIES FOR UNDERGROUND NETWORKS FOR NATURAL GAS DISTRIBUTION	DOCUMENT NO.	Rev
		11-0269-02-07-02-004	0
		Page 13 of 20	

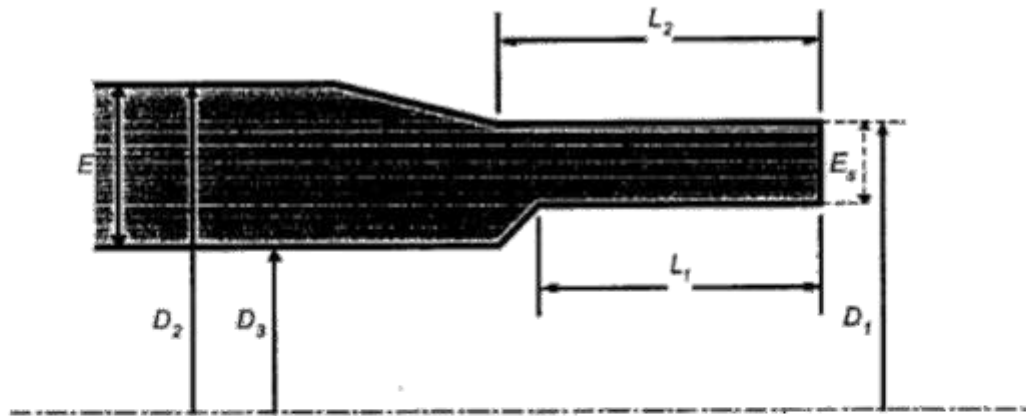

FIG.3

- D1 The “average external diameter of the end to be welded measured on any plane parallel to the inlet/entry plane at a distance where this plane does not exceed L2 (tubular section).
- D2 The “average external diameter of the body” of the tip of the accessory.
- D3 “Minimum drilling/boring” — that is the minimum diameter of the passage through the body of the accessory. Measuring of the diameter must not include any ribbing due to welding.
- E “Thickness of the accessory body wall” — that is: the thickness measured at any point of the accessory wall.
- Es “Thickness of the end to be welded” measured at any point but where the distance does not exceed L1 (length that can be cut) compared to the inlet! entry plane, must be equal to the thickness of the nominal pipe wall.
- L1 The “cuttable section” of the end to be welded — that is the initial depth of the tip of the insertion section, necessary for end-to-end welding or for starting an end-to- end weld again.
- L2 The “tubular section” of the end to be welded — that is the initial length of this section. This tubular section permits the following in all types of combination:
- Use of the clamp stirrups, as is essential for end-to-end welding, or for electrofusion.
 - Assembly using electrofusion sleeves.

	PE ACCESSORIES FOR UNDERGROUND NETWORKS FOR NATURAL GAS DISTRIBUTION	DOCUMENT NO.	Rev
		11-0269-02-07-02-004	0
		Page 14 of 20	

8.0 ACCESSORY MECHANICAL CHARACTERISTICS

All accessories must obey the requirements and tests described in the chapter concerning the mechanical characteristics of EN standard 1555-3. They must also comply with the hydrostatic test conditions described in the same standard.

They must be controlled as described in the same standard.

9.0 PHYSICAL CHARACTERISTICS

All accessories must obey the requirements and tests described in the chapter concerning the mechanical characteristics of EN standard 1555-3

They must be controlled as described in the same standard.

10.0 PRODUCT APPROVAL

The product will be approved by the Owner/ owner representative if all results of the tests, controls and checking prescribed by this specification are satisfying.

The manufacturer will provide a complete approval dossier including all the product characteristics specified in 6.1. (technical dossier) and the results of tests prescribed in these specifications. The number of tests run on the product must comply with EN standard 1555-7. The results of these tests described in the approval dossier must be confirmed by the Owner/ owner representative authorised laboratory. Hydraulic testing must be continued until the rupture of at least two test samples for each set of tests. (max. 2000 hours).

All changes made to the approved product must be communicated to the Ovine, and this entails further control checks for approval.

Any requirement not observed or test missing from this specification will result in the withdrawal of the product approval and can even result on annulment of contract.

11.0 MARKING

11.1 ACCESSORY MARKING

11.1.1. Identification marking will be made directly on the accessory. The system used to make the product must not provoke cracking or other faults. All marking must be permanently legible for the product life under standard stocking conditions, exposure to external weather conditions, treatment, installation, and use. All electrofusion fittings shall be bar coded. Bar coding shall be such so that it enables the bar code reader to directly transfer fusion data to control unit. Bar coding shall be long lasting even when the joint is buried in corrosive soil, alternatively each fitting shall have a data card which can be read by the computer and thereafter the card is positioned with the joint.

11.1.2. Where the products are printed, the colour of the printed identification mark must be different from that of the basic product colour.

	PE ACCESSORIES FOR UNDERGROUND NETWORKS FOR NATURAL GAS DISTRIBUTION	DOCUMENT NO.	Rev
		11-0269-02-07-02-004	0
		Page 15 of 20	

11.1.3. Marking quality and size must be of a standard that can be read with the naked eye without magnification.
 No marking must be printed on the minimum length of the insertion section of accessories.

11.1.4. Each accessory must be marked with at least the obligatory details required by EN standard 1555-3. The marking must be printed on the accessory itself or on a label as shown in the standard described above
 The SDR pipe range that are to be fitted with these accessories must be clearly marked on the fitting. Details must include: each SDR value, or the upper and lower value of the permitted SDR range.

11.2. COMPLEMENTARY INFORMATION

All complementary information on welding conditions (welding time and cooling time) can also be described on a label affixed to the accessory or delivered with the accessory.

12.0 PACKAGING AND DELIVERY

Normally all accessories are packed separately in plastic sheeting and/or cardboard boxes. Sometimes they can be loosely packed together where there is no danger of damage or deterioration or loss of loose parts.

All boxes and plastic sheeting must be marked with at least one label showing the manufacturer's name, the product type, part measurements, and number of single parts contained in the box or bag, plus all details necessary for stocking and stock expiry dates.

All electrofusion accessories must be printed with a bar code and an individual magnetic card. The magnetic card contains the welding parameters that have been encoded in the magnetic track, as well as the bar code printed on the card. Coding must be carried out according to prescriptions included in ISO TR 13950 standards.

With regard to stocking guarantee, accessories must correspond with the prescriptions of the local laws & regulations if any. If the guarantee period decided by the manufacturer is shorter than that in these document, the Owner/ owner representative must be informed in writing at the time of the offer.

13.0 QUALITY CONTROL

13.1 GENERAL RULINGS

13.1.1 Manufacturer's responsibility

The manufacturer is entirely responsible for the quality of the PE accessories manufactured by his firm. All control checks prescribed above do not relieve him of this responsibility.

To ensure that all PE accessories are in compliance with the specification in all aspects, they must be controlled by the plant control service, which must be independent from the manufacturing department. All PE accessories supplied are guaranteed for a one-year period after application for use, that is a maximum of three years after the date of production.

	PE ACCESSORIES FOR UNDERGROUND NETWORKS FOR NATURAL GAS DISTRIBUTION	DOCUMENT NO.	Rev
		11-0269-02-07-02-004	0
		Page 16 of 20	

13.1.2 Quality assurance

The manufacturer must have some form of quality control to ensure that products comply with EN standards 26901 or 26902. The quality assurance manual must be made available to the Owner/ owner representative Control Service or an external Control laboratory appointed by him. The system of quality assurance must be certified by an authorised body.

13.2 CONTROLS

13.2.1 Control testing by the manufacturer

13.2.1.1 By material batch.

The manufacturer demands a certificate from the raw material manufacturer including the following:

- Fluid index
- Water content
- Volume mass
- Carbon black or yellow stabilizing agent content
- Carbon black or yellow stabilizing agent quality
- OIT value (thermal stability)

13.2.1.2 By accessory batch

The manufacturer must run control checks as follows:

- Appearance / colour
- Measurements
- Hydraulic testing
- Electrical resistance
- Printing/markings.

Control checks and the number of tests must be carried out according to the prescriptions of the EN standard 1555-3

Also refer to table N° 8, paragraph 4.2.3. "Lot release tests" of EN standard 1555-7.

The results must be written out in documents that contain the complete identification of the accessory batch.

These documents must be made immediately available for the Owner representative.

13.2.2 Plant Reception by the Owner Control Service representative

13.2.2.1 General information

All quality controls must be run in the presence of the Owner Control Service representative.

All tests and control checks must comply with appropriate standard prescriptions and with the specific specifications established with the order.

At each visit by the Owner representative, the manufacturer must provide, free of charge, all means and

	PE ACCESSORIES FOR UNDERGROUND NETWORKS FOR NATURAL GAS DISTRIBUTION	DOCUMENT NO.	Rev
		11-0269-02-07-02-004	0
		Page 17 of 20	

personnel necessary for running the established control checks.

While the order is under production, the Owner representative must have access to stocking installations of all raw materials before manufacturing, manufacturing and control installations, as well as the accessory stocking areas for any control checks he is responsible for.

During his visits, the Owner representative will receive a certificate as soon as he reaches the plant for each batch of accessories presented for reception.

Each time this is requested by the Owner representative, the manufacturer must provide recent reports of all control checks and measuring instrument results and testing results.

13.2.2.2 Convocation for reception

Convocation instructions for reception are to be defined with the order.

13.2.2.3 Reception control checks

For each accessory batch or any fractions of the batch, minimal batch sampling is established in annexed enclosure 3. These control checks and tests are to be run according to the prescriptions of EN standard 1555-3

13.3 ACCEPTANCE OR REFUSAL

13.3.1. Appearance, measurements and marking

Any requirements not supplied will lead to the refusal of the complete batch. However in the case where a batch is refused, it can be presented for approval again after a control check, on agreement with the Owner/Owner representatives Control Service.

13.3.2. Control check on characteristics

All results that do not comply with the specification prescriptions and the particular specifications requested with the order, demand counter-testing on at least double the number of the samples previously tested. If the undesirable result is confirmed, then the batch is refused permanently. If the result is positive, then the batch will be accepted.

As a complementary control check, other analyses and/or tests can be run after common agreement and at the manufacturer's cost.

	PE ACCESSORIES FOR UNDERGROUND NETWORKS FOR NATURAL GAS DISTRIBUTION	DOCUMENT NO.	Rev
		11-0269-02-07-02-004	0
		Page 18 of 20	

ANNEXURE - 1

CONNECTOR FOR ELECTROFUSION ACCESSORIES

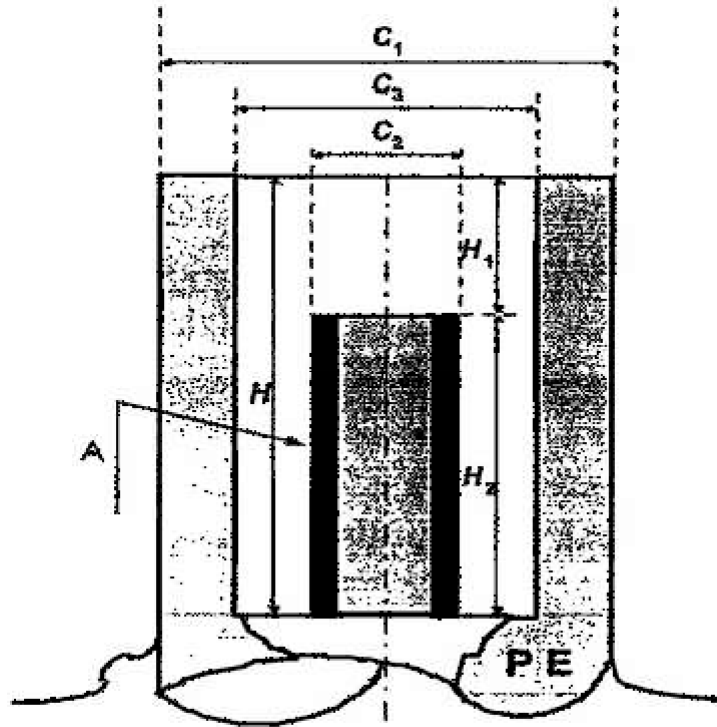

Symbols

C1	External diameter of connector	$C1 \geq 11.8 \text{ mm}$
C2	Diameter of active part of connector	$C2 = 4.0 \pm 0.03 \text{ mm}$
C3	Internal diameter of connector	$C3 = 9.5 \pm 1.0 \text{ mm}$
C4	Max. Diameter of active part foot	$C4 \geq 6.0$
H	Connector internal depth	$H > 12.0$ $H > H1 + H2$
H1	Distance between upper part of connector and active part	$H1 = 3.2 \pm 0.5$
H2	Height of active part	$H2 \geq 7.0 \text{ mm}$
A	Active zone.	

	PE ACCESSORIES FOR UNDERGROUND NETWORKS FOR NATURAL GAS DISTRIBUTION	DOCUMENT NO.	Rev
		11-0269-02-07-02-004	0
		Page 19 of 20	

RECEPTION AT MANUFACTURER'S PLANT.

Characteristics	Reference EN 1555-3	Minimum drill tests / frequency	N° of samples	N° of measured samples
Appearance /colour	5.2 /5.3	1 x /size/product type / internal space	10	1
Measurements	6	1 x /size/product type / internal space	10	1
Thermal stability (OIT)	8.2	1 x batch	1	1
Meltmass flow rate (MFR)	8.2	1 x batch	1	1
Electrical resistance	5.6	1x/size/product type/internal space	5	1
Cohesion resistance	7.2	1x/size/product type	2	1
End-to-end seam resistance to traction (cohesion resistance)	7.2	1x/size/product type	2	1
Shock resistance	7.2	1x/size/product type	1	1
Load loss	7.2	1x/size/product type	1	1
Marking	10.2	1x/size/product type	1	1

	PE ACCESSORIES FOR UNDERGROUND NETWORKS FOR NATURAL GAS DISTRIBUTION	DOCUMENT NO.	Rev
		11-0269-02-07-02-004	0
		Page 20 of 20	

AAVANTIKA GAS LIMITED
CITY GAS DISTRIBUTION PROJECT



POLYETHYLENE COMPOUNDS FOR MANUFACTURE OF PIPES AND FITTINGS FOR UNDERGROUND NETWORKS FOR NATURAL GAS DISTRIBUTION ACCEPTANCE PROCEDURE					CLIENT JOB NO. -	
					TOTAL SHEETS 12	
DOCUMENT NO	11	0269	02	07	02	005

--	--	--	--	--	--

0	18.10.09	ISSUED FOR CLIENT COMMNETS	AP	SB	SB
A	16.10.09	ISSUED FOR IDC	AP	SB	SB
REV	DATE	DESCRIPTION	PREP	CHK	APPR

**POLYETHYLENE COMPOUNDS FOR MANUFACTURE OF PIPES AND FITTINGS FOR
UNDERGROUND NETWORKS FOR NATURAL GAS DISTRIBUTION ACCEPTANCE PROCEDURE**

TABLE OF CONTENTS

1.0 SUBJECT 4

2.0 REFERENCES: STANDARDS AND SPECIFICATIONS 4

3.0 DEFINITIONS AND SYMBOLS..... 5

4.0 GENERAL SPECIFICATIONS 6

5.0 SUMMARY OF THE PROCEDURE..... 7

6.0 TECHNICAL FILE 7

7.0 CONFIRMATION TESTS 9

8.0 FOLLOW-UP 10

APPENDIX - 1 (Technical Data Sheet) 12

**POLYETHYLENE COMPOUNDS FOR
MANUFACTURE OF PIPES AND
FITTINGS FOR UNDERGROUND
NETWORKS FOR NATURAL GAS
DISTRIBUTION ACCEPTANCE
PROCEDURE**

DOCUMENT NO.

REV

11-0269-02-07-02-005

0

SHEET Page 3 of 12

The information contained in this document should be treated as confidential and is to be considered as the exclusive property of WGI.

Direct or indirect use of this document or any part of it is only allowed for WGI productions.

1.0 SUBJECT

This specification describes the procedure to be followed for acceptance of a polyethylene (PE) compound for manufacture of natural gas underground distribution systems.

This specification also gives the minimum requirements which have to be met by PE compounds for manufacture of pipes, fillings and valves and for the construction of underground distribution systems for natural gas.

The compounds that meet this specification must at the minimum be PE 100.

The color shall be orange in accordance with the local requirements.

2.0 REFERENCES: STANDARDS AND SPECIFICATIONS

This section contains the list of standards and specifications referred to in this specification.

EN 728: 1997 Plastics piping and ducting systems - Polyolefin pipes and fillings - Determination of oxidation induction time.

prEN 1555-1 Plastics piping systems for the supply of gaseous fuels - Polyethylene (PE) - Part 1: General

prEN 1555-7 Plastics piping systems for the supply of gaseous fuels - Polyethylene (PE) - Part 7: Assessment of conformity.

prEN 12099 Plastics piping systems - Polyethylene piping materials and components - Determination of volatile content.

prEN 12118 Plastics piping systems - Determination of moisture content in plastics by conformity.

EN ISO 12162: 1995 Thermoplastics materials for pipes and fittings for pressure applications - Classification and designation - Overall service (design) coefficient.

	POLYETHYLENE COMPOUNDS FOR MANUFACTURE OF PIPES AND FITTINGS FOR UNDERGROUND NETWORKS FOR NATURAL GAS DISTRIBUTION ACCEPTANCE PROCEDURE	DOCUMENT NO.	REV
		11-0269-02-07-02-005	0
		SHEET Page 4 of 12	

EN ISO 13478: 1997	Thermoplastics pipes for the conveyance of fluids - Determination of resistance to rapid crack propagation (RCP) - Full-scale test (FST).
EN ISO 13479: 1997	Thermoplastics pipes for the conveyance of fluids - Determination of resistance to crack propagation (RCP) - Test method for slow crack growth on notched pipes (notch test).
EN 45001: 1990	General criteria for the operation of testing laboratories.
ISO 1133: 1997	Determination of the melt mass-flow rate (MFR) and the melt volume-flow rate (MVR) of thermoplastics.
ISO 6964: 1996	Polyolefin pipes and fittings - Determination of carbon black content by calcination and pyrolysis Test method and basic specification.
ISO/DIS 9080	Plastics piping and ducting systems-Determination of the long-term hydrostatic strength of thermoplastics materials in pipe from by extrapolation.
ISO 11420: 1996	Method for the assessment of the degree of carbon black dispersion in polyolefin pipes, fittings and compounds.
ISO 13477: 1997	Thermoplastics pipes for the conveyance of fluids - Determination of resistance to rapid crack propagation (RCP) - Small-scale-steady-state test (S4 test).
IS 14885	Polyethylene Pipes for the Supply of Gaseous Fuels-Specification
11-0269-02-07-02-001 to 11-0269-02-07-02-003	Polyethylene pipes for underground networks for natural gas distribution
11-0269-02-07-02-004	PE Accessories for underground networks for natural gas distribution

3.0 DEFINITIONS AND SYMBOLS

3.1. LOWER CONFIDENCE LIMIT (LCL)

A quantity with the dimensions of stress, in megapascal, which can be considered as a property of the

**POLYETHYLENE COMPOUNDS FOR
MANUFACTURE OF PIPES AND
FITTINGS FOR UNDERGROUND
NETWORKS FOR NATURAL GAS
DISTRIBUTION ACCEPTANCE
PROCEDURE**

DOCUMENT NO.

REV

11-0269-02-07-02-005

0

SHEET Page 5 of 12

material under consideration and represents the 97.5% lower confidence limit of the predicted long-term hydrostatic strength at a temperature of 20 degree C for 50 years with internal water pressure.

3.2. MINIMUM REQUIRED STRENGTH (MRS 10)

Standardised class of compounds for which the LCL is equal to 10.

3.3. PE 100

Standard designation for PE compounds in class MRS 10.

For such PE compounds, the long-term hydrostatic strength — calculated and classified according to the standardised method (ISO 9080 and ISO 12162) for a temperature of 20°C, a period of 50 years and a reliability of 97.5 % — must be at least 10 MPa.

3.4. BATCH OF COMPOUND

By batch of compound is meant a homogeneous quantity of PE compound of the same origin and of a particular brand.

The batch must be registered under a single identification number (batch number) which leaves no doubt as to the origin, identity and date of manufacture of the compound.

3.5. BATCH OF PIPES

By batch of pipes is meant a homogenous lot of pipes with identical dimensions, made in a continuous process by the same extrusion machine and from the same batch of compound.

4.0 GENERAL SPECIFICATIONS

The PE compounds that are acceptable according to the requirements of this specification must conform to the requirements for PE 100 described in prEN1555-1.

If the proposed compound is destined for manufacture of pipes, then the acceptance procedure is carried out as described in this specification.

If the proposed compound is destined for manufacture of fittings, then the first stage (section 6) of this acceptance procedure is carried out, after which type tests are carried out on the fittings manufactured from the material concerned. An independent laboratory appointed by Owner/ owner representative will then evaluate whether conformity with the characteristics mentioned in the technical file has been proved, on the basis of the provisions of prEN 1555-7 and WGI specification 11-0269-02-07-02-004.

POLYETHYLENE COMPOUNDS FOR MANUFACTURE OF PIPES AND FITTINGS FOR UNDERGROUND NETWORKS FOR NATURAL GAS DISTRIBUTION ACCEPTANCE PROCEDURE	DOCUMENT NO.	REV
	11-0269-02-07-02-005	0
	SHEET Page 6 of 12	

5.0 SUMMARY OF THE PROCEDURE

5.1. GENERAL

The acceptance procedure for PE compounds comprises two stages, namely the evaluation of the technical file and the confirmation tests. The different steps are carried out in the order described below. The tests which form part of the technical file are carried out on pipes or samples supplied by the compounds manufacturer. In principle, all tests mentioned in the technical file are carried out on pipes from the same batch.

The tests mentioned in chapter 7 are carried out on pipes manufactured by a pipe manufacturer chosen by Owner/ Owner Representative .

The tests mentioned in chapter 6.1 (table 1), 6.2 and 7 are carried out in a laboratory appointed by Owner/ Owner Representative.

5.2. APPLICATION FOR APPROVAL

A manufacturer that wishes to have a certain PE compound classified for the manufacture of PE gas components must submit a written application to Owner.

This application must be accompanied by a clear description of the compound concerned, including the technical characteristics.

All correspondence must be in English.

6.0 TECHNICAL FILE

6.1. EVALUATION

If the application is taken into consideration by Owner/ Owner Representative, the compound manufacturer must submit a technical file to a laboratory appointed by Owner/ Owner Representative. This technical file must include the following information:

- name and class of the PE compound;
- technical characteristics of the compound, with reference to the standard;
- a dossier with test results, from an independent laboratory, showing that the proposed compound meets the requirements of prEN 1555-1 for a PE 100 compound. The dossier must also state which tests have been carried out on the same batch of pipes or test samples, including the identification of their origin.

The laboratory chosen by Owner/ Owner Representative will also evaluate the conformity of this dossier, taking the following rules into account:

- a) If the tests mentioned in the technical file have been carried out by a laboratory accredited according to EN 45001, and if the tests have been carried out on the same batch of pipes for the required diameter and

wall thickness, then the evaluation will be limited to an examination of the dossier in accordance with the provisions of prEN 1555-1 and the quantity of test samples laid down in 1555-7;

b) If the tests mentioned in the technical file have been carried out by a laboratory that is not accredited according to EN 45001 and/or on different batches of pipes for the same diameters/wall thickness, then the evaluation will be done on the basis of further tests in order to confirm the characteristics mentioned in the technical file.

c) The characteristics for rapid crack propagation (RCP) and slow crack propagation (SCG), as mentioned in the technical file, must comply with the requirements of the standard. Furthermore, the requirements of table 1 must be met:

Characteristic	Requirement	Standard
PcS4	DN 250- SDR 11 0°C - > 3,5 bar	ISO 13477
PcFS	DN 250- SDR 11 0°C-> 15 bar	EN ISO 13478
SCG	DN250-SDR11 80°C-σ4,6->500h	EN1SO13479

The tests mentioned in table I must be carried out by an independent laboratory appointed by Owner/ Owner Representative. The three series of tests must be carried out on the same batch of pipes.

If it emerges from the evaluation of the technical file that conformity with prEN 1555-1 is guaranteed, then the next stage of the procedure can commence, as described in section 7.

6.2. ADDITIONAL TESTS

6.2.1. General

If from the evaluation L emerges that the dossier submitted is incomplete or does not offer the necessary guarantees of conformity with the standard, then additional tests will be carried out by the laboratory appointed by Owner, at the cost of the compound manufacturer.

	POLYETHYLENE COMPOUNDS FOR MANUFACTURE OF PIPES AND FITTINGS FOR UNDERGROUND NETWORKS FOR NATURAL GAS DISTRIBUTION ACCEPTANCE PROCEDURE	DOCUMENT NO.	REV
		11-0269-02-07-02-005	0
		SHEET Page 8 of 12	

The same procedure will be followed if the technical file has been drawn up by a laboratory that is not accredited and/or if several batches of pipes have been used for each diameter/wall thickness in carrying out the tests.

6.2.2. Delivery of the pipes

The required batch of pipes must be delivered by the compound manufacturer, the pipes having been produced by a pipe manufacturer who at that moment is a Owner/ owner representative supplier. The number of pipes must be based on the numbers and frequencies mentioned in prEN 1555-7.

If the technical file is based on tests carried out by a non-accredited laboratory and/or carried out on several batches of pipes per diameter/wall thickness, then the tests will repeated on at least half of the required test samples; if the number thus calculated is not a whole number, the number of test samples taken will be equal to the next whole number.

6.2.3. Test results

If from the additional tests it appears that conformity with prEN 1555-1 is guaranteed, then the next phase of the procedure can commence, as described in section 7.

If despite the additional tests no unambiguous decision can be taken regarding the conformity of the compound, then further additional tests will be carried out, until the number of test samples is at maximum equal to the number specified in the standard concerned. For this purpose, the manufacturer must keep sufficient pipes of the same batch in reserve.

If the evaluation is still not positive after the maximum number of samples has been tested, then the compound will be considered as not accepted.

7.0 CONFIRMATION TESTS

The second stage of the acceptance covers the industrial production of pipes, the verification of the characteristics, the laying of the pipes and the fusion to existing PE systems.

This second stage of the acceptance is carried out by Owner/ owner representative.

Before this stage can commence, the manufacturer must provide Owner/ owner representative with a technical data sheet (see appendix 1) showing the limit values for the characteristics of the compound concerned.

For the purpose of carrying out this part of the procedure, Owner/ owner representative will order a batch of pipes from one of its pipe manufacturers. After verification of the characteristics in the factory and

	POLYETHYLENE COMPOUNDS FOR MANUFACTURE OF PIPES AND FITTINGS FOR UNDERGROUND NETWORKS FOR NATURAL GAS DISTRIBUTION ACCEPTANCE PROCEDURE	DOCUMENT NO.	REV
		11-0269-02-07-02-005	0
		SHEET Page 9 of 12	

confirmation by an independent laboratory, the pipes will be installed in the Owner/ owner representative gas distribution network, taking into account the following aspects:

- Any problems with delivery and with extrusion of the compound will be noted.
- The limits of the characteristics mentioned in the technical data sheet.
- For characteristics not included in the technical data sheet, the measured value may deviate by max. 30% from the average values mentioned in the technical file, to the extent that these are relevant and not in conflict with the requirements of the standard.
- Any problems with laying or welding or connecting the pipes; these will be noted.

If from the test results it appears that the characteristics of the compound and/or pipes do not comply with the requirements, or if anomalies are found in laying and/or welding of the pipes, then the acceptance procedure will be provisionally suspended. The problems found will be analysed in consultation with the compound manufacturer, and an attempt will be made to find solutions which are acceptable to both parties. If this turns out to be impossible, then the compound will be considered as not accepted.

In such a case, the costs of the second stage could be charged to the compound manufacturer.

If the second stage of the procedure is successfully completed, then the compound is accepted and will be included in the list of "Approved PE Compounds". This list is published in the WGI specifications for PE pipes (11-0269-02-07-02-001 to 003) and PE fittings (11-0269-02-07-02-005). The materials will be included when the list is next published (around once every two year).

8.0 FOLLOW-UP

8.1. TECHNICAL DATA SHEET

The manufacturer must supply Owner/ owner representative with a technical data sheet, as described in Appendix 1, with permission for Owner/ owner representative to publish this technical data sheet in the specifications for PE pipes and fittings, for as long as the compound is included in the list of approved compounds.

The data entered on this data sheet apply as limit values for the compound concerned. Whenever one or more characteristics of a batch of compounds falls outside these limits, then the batch will be automatically refused for production of components destined for our gas network.

8.2. CONTINUITY OF THE COMPOUND

No alterations may be made to the compound without prior permission from Owner/ owner representative.

**POLYETHYLENE COMPOUNDS FOR
MANUFACTURE OF PIPES AND
FITTINGS FOR UNDERGROUND
NETWORKS FOR NATURAL GAS
DISTRIBUTION ACCEPTANCE
PROCEDURE**

DOCUMENT NO.

REV

11-0269-02-07-02-005

0

SHEET Page 10 of 12

As mentioned in 8.1, the limits mentioned in the technical data sheet must be respected. Furthermore, in the case of characteristics not included in the technical data sheet, the measured values may not deviate by more than 30% from the average value mentioned in the technical file, to the extent that these are relevant and not in conflict with the requirements of the standard.

Each change that affects the final characteristics of the compound can result in additional tests being carried out by the compound manufacturer in accordance with the provisions of prEN 1555-7 appendix A. The procedures for the test shall correspond to those described in section 6.1 of this specification.

POLYETHYLENE COMPOUNDS FOR MANUFACTURE OF PIPES AND FITTINGS FOR UNDERGROUND NETWORKS FOR NATURAL GAS DISTRIBUTION ACCEPTANCE PROCEDURE	DOCUMENT NO.	REV
	11-0269-02-07-02-005	0
	SHEET Page 11 of 12	

APPENDIX - 1 (Technical Data Sheet)

Characteristics of (name of PE compound) as per prEN 1555-1

Characteristics	Standard	Specification
MRS	EN ISO 12162	MPa
Density min. max.	Method D of ISO 1183	kg/m ³ kg/m ³
MFR190/5 mm. max.	ISO 1133	g/10 min g/10 min
Volatile content max.	prEN 12099	mg/kg
Water content max.	prEN 12118	mg/kg
Carbon black content Min. Max.	ISO 6964	% - %
Carbon black dispersion max	ISO 11420	<=Grade
OIT at 210°C min.	EN728	...min

Company

Person responsible

Position

Signature

	POLYETHYLENE COMPOUNDS FOR MANUFACTURE OF PIPES AND FITTINGS FOR UNDERGROUND NETWORKS FOR NATURAL GAS DISTRIBUTION ACCEPTANCE PROCEDURE	DOCUMENT NO.	REV
		11-0269-02-07-02-005	0
		SHEET Page 12 of 12	

AAVANTIKA GAS LIMITED
CITY GAS DISTRIBUTION PROJECT



**SUPPLEMENTARY PROCEDURE FOR TYPE APPROVAL OF
POLYETHYLENE PIPES FOR UNDERGROUND GAS NETWORKS**

CLIENT JOB NO.

-

TOTAL SHEETS

14

DOCUMENT NO

11

0269

02

07

02

007

REV	DATE	DESCRIPTION	PREP	CHK	APPR
0	18.10.09	ISSUED FOR CLIENT COMMNETS	AP	SB	SB
A	16.10.09	ISSUED FOR IDC	AP	SB	SB

**SUPPLEMENTARY PROCEDURES FOR TYPE-APPROVAL OF
POLYETHYLENE PIPES FOR UNDERGROUND GAS NETWORKS**

	Supplementary Procedure for Type approval of Polyethylene Pipes for Underground Gas Networks	DOCUMENT NO.	Rev
		11-0269-02-07-02-007	0
		Page 2 of 14	

TABLE OF CONTENTS

1.0 SUBJECT 4

2.0 AREA OF APPLICATION 4

3.0 REFERENCES 4

4.0 DEFINITIONS 4

5.0 PIPE TYPE-APPROVAL TESTS 4

6 TECHNICAL TYPE-APPROVAL FILE 5

APPENDIX 1 - GENERAL INFORMATION 6

APPENDIX 1.1 — FACTORY 6

APPENDIX 1.2 — EXTRUSION LINES 7

APPENDIX 1.3 - LABORATORY EQUIPMENT 9

APPENDIX 2- TEST PROGRAMME 11

1.1 GENERAL 11

1.2 RESIN TESTING 11

APPENDIX 3—SEALS 14

	Supplementary Procedure for Type approval of Polyethylene Pipes for Underground Gas Networks	DOCUMENT NO.	Rev
		11-0269-02-07-02-007	0
		Page 3 of 14	

1.0 SUBJECT

This procedure supplements and defines the practical arrangements based on the provisions in technical specifications 11-0269-02-07-02-001 "Polyethylene pipes for underground networks for natural gas distribution", 11-0269-02-07-02-002 "Polyethylene pipes for underground networks for natural gas distribution — Technical data sheet" and 11-0269-02-07-02-003 "Polyethylene pipes for underground networks for natural gas distribution — Quality Control of pipes" for the purpose of type-approval of the product.

It defines the simplifying procedures applicable in certain conditions for type-approval of the pipes based on tests carried out on similar types in accordance with the methods of specification 11-0269-02-07-02-001, without repeating all the tests specified in the latter.

It stipulates the conditions for type-approval of the seals to be fitted on the pipes.

2.0 AREA OF APPLICATION

The procedure is applicable to type-approval of the pipe and of the seals as laid down in the Technical Specification 11-0269-02-07-02-001.

3.0 REFERENCES

- 11-0269-02-07-02-001: Polyethylene pipes for underground networks for natural gas distribution.
- 11-0269-02-07-02-002: Polyethylene pipes for underground networks for natural gas distribution — Technical data sheet.
- 11-0269-02-07-02-003: Polyethylene pipes for underground networks for natural gas distribution — Quality Control of pipes.
- IS 14885: Polyethylene Pipes for the Supply of Gaseous Fuels-Specification

4.0 DEFINITIONS

Extrusion line:

The term extrusion line covers:

- the actual extruder and its tools (screw, die, etc.)
- the calibrators
- the delivery device (any material-drying device and gravimetric gauging system)
- the cooling system(s) (type of cooling, lengths of different tanks, etc.),
- any rolling device.

Batch of pipes:

See 11-0269-02-07-02-001§ 3.2.

Type of pipes

Type of pipes means pipes with the following identical characteristics:

- Nominal diameter
- Nominal thickness
- With or without optional marking (coextruded lines)
- Material
- Packaging (straight or rolled length)

5.0 PIPE TYPE-APPROVAL TESTS

5.1. GENERAL

Prior to type-approval, the information specified in the documents in Appendix 1 must be sent for the attention of the head of the Quality Control Department of the Owner/ owner representative or the

	Supplementary Procedure for Type approval of Polyethylene Pipes for Underground Gas Networks	DOCUMENT NO.	Rev
		11-0269-02-07-02-007	0
		Page 4 of 14	

recognized control organization.

Type-approval tests on a type of pipes must be carried on all types of pipes intended for the Owner/ owner representative for each extrusion line.

The pipe type-approval tests are defined in Appendix 2.

For the purposes of type-approval of a type of pipe, the main extrusion parameters for the pipes subjected to the type-approval tests are notified. These parameters must include in each case the extrusion rate expressed in kg/hour and the main limiting factor (e.g. cooling capacity, etc.).

The simplifying provisions in the following sections may be applied, however.

5.2. SIMPLIFYING PROVISIONS

5.2.1. Extrusion lines

If on the same production line using the same approved material, pipes of nominal diameter and nominal thickness, corresponding to the nominal maximum diameter and thickness manufactured at maximum rate Q1 in kg/h notified by the manufacturer have been type-approved, and if

1) pipes of nominal diameter D2 and nominal thickness e2, corresponding to the nominal minimum diameter and thickness manufactured at the maximum rate Q2 in kg/h notified by the manufacturer have been type-approved, then pipes of diameter $D1 \leq D \leq D2$ and nominal thickness e1 shall be considered to be type-approved.

For each type-approved type of pipe, the manufacturer shall state the maximum extrusion rate for the extrusion line in question.

5.2.2. Rolled pipes-straight pipes

The provisions of section 5.2.1 also apply to rolled pipes.

The rolling diameter for type-approval is the minimum rolling diameter laid down in specification 11-0269-02-07-02-001

If a type of rolled pipe is type-approved, then straight pipes manufactured at the maximum rate Q1, using the same material, on the same line with the same nominal diameters and thicknesses, are type-approved. In this case the extrusion rate for the straight pipes must not exceed Q1.

5.2.2 Pipes With Optional Marking

In addition to the test programme defined in § 5.1., the tests described in Appendix 2 must be carried out on samples of pipes to be type-approved.

The provisions of sections 5.2.1. and 5.2.2. also apply to pipes with optional marking.

If a type of pipe with optional marking is type-approved and if the rate of production of the latter is less than or equal to that of the type of pipe with marking, then the type of pipe without corresponding marking is type-approved.

6 TECHNICAL TYPE-APPROVAL FILE

The technical type-approval file includes the following documents and information:

- 1) General information listed in Appendices 1.1., 1.2. and 1.3.
- 2) Test reports as defined in section 5 and Appendix 2.
- 3) Information on seals as specified in Appendix 3.



APPENDIX 1 - GENERAL INFORMATION

APPENDIX 1.1 — FACTORY

Work system Number of production teams Number of days' production per week	
<u>Total area occupied in m²</u>	
<u>Production bay in m²</u>	
PE pipes — packaging Straight lengths in crates Rolls of pipes Pipes rolled on drums	
Storage of granulate Bags Silos Octabins	
Handling methods Pipes Crates Drums	
Storage Crates: Covered or outdoor park Type of ground Handling and loading methods Rolls: Covered or outdoor park Type of ground Handling and loading methods Drums: Covered or outdoor park Type of ground Handling and loading methods Transport methods	
Manufacturer's drums Number of drums available at manufacturer's premises	

	Supplementary Procedure for Type approval of Polyethylene Pipes for Underground Gas Networks	DOCUMENT NO.	Rev
		11-0269-02-07-02-007	0
		Page 6 of 14	

APPENDIX 1.2 — EXTRUSION LINES

The following information must be provided for each extrusion line.

<p>Fusion Line</p> <p>Line no.</p> <p>Make</p> <p>Type</p> <p>Year of manufacture</p> <p>Screw length expressed in multiples of the diameter</p> <p>Screw diameter (in mm)</p> <p>Maximum diameter and thickness of pipe which can be produced by the extruder</p> <p>Minimum diameter and thickness of pipe which can be produced by the extruder</p> <p>Raw materials which can be extruded by the extruder</p> <p>Theoretical rate in kg/hour</p>	
<p>ASSOCIATED COEXTRUSION EQUIPMENT</p> <p>Make</p> <p>Type</p>	
<p>'DRYER</p> <p>Make and type</p>	
<p>CALIBRATOR</p> <p>Type</p> <p>Length</p>	

<p>COOLING TANKS</p> <p>Number</p> <p>Length per tank</p>	
<p>MARKER</p> <p>Type</p>	
<p>DRAWER</p> <p>Type</p>	
<p>SA W</p> <p>Type</p>	
<p>CONTINUOUS THICKNESS MEASURING SYSTEM</p> <p>Operating principle</p> <p>Make</p> <p>Type</p> <p>Measurement recording equipment</p>	

APPENDIX 1.3 - LABORATORY EQUIPMENT

<p>THICKNESS MEASURING SYSTEM</p> <p>Operating principle</p> <p>Make</p> <p>Type</p> <p>Accuracy of measurement</p> <p>Measurement recording equipment</p>	
<p>ANALYTICAL SCALES</p> <p>Make</p> <p>Type</p> <p>Accuracy</p>	
<p>DEVICE FOR MEASURING MELT MASS-FLOW RATE</p> <p>Make</p> <p>Type</p>	
<p>EQUIPMENT FOR MEASURING VOLATILE CONTENT</p>	
<p>EQUIPMENT FOR MEASURING WATER CONTENT -</p> <p>KARL FISCHER METHOD</p>	
<p>EQUIPMENT FOR MEASURING THERMAL STABILITY</p> <p>Make</p> <p>Type</p> <p>Recorder</p>	
<p>EQUIPMENT FOR MEASURING INTERNAL STRESSES</p> <p>Ovens</p> <p>Baths</p>	

	<p align="center">Supplementary Procedure for Type approval of Polyethylene Pipes for Underground Gas Networks</p>	<p align="center">DOCUMENT NO.</p>	<p align="center">Rev</p>
		<p align="center">11-0269-02-07-02-007</p>	<p align="center">0</p>
<p align="center">Page 9 of 14</p>			

<p>RESISTANCE TO INTERNAL HYDRAULIC PRESSURE</p> <p>Baths at 20°C (maximum number of samples for diameters 110mm and 250 mm)</p> <p>Baths at 80°C (maximum number of samples for diameters 110mm and 250 mm)</p> <p>Number of head pairs available for each diameter</p>	
<p>TRACTION MACHINE</p> <p>Make</p> <p>Type</p> <p>Capacity</p> <p>Accuracy</p>	
<p>WELDING MACHINE</p> <p>Make and type</p>	

APPENDIX 2- TEST PROGRAMME

1.1 GENERAL

If the manufacturer does not have the equipment to carry out these tests properly, they shall be carried out at the manufacturer's expense in a laboratory chosen by the Owner/ owner representative.

1.2 RESIN TESTING

The following tests and checks must be carried out on a representative sample of the batch of raw material. In addition, the manufacturer must keep an adequate sample (± 1 kg) of granulate for any repeat tests.

1.2.1 BLACK RESIN

TABLE OF TESTS ON MATERIALS

Test	Quality criterion as per specification 11-0269-02-07-02-001	Test method as per specification 11-0269-02-07-02-001	Number of samples per batch
Density	§ 5.2.1.3	§ 6.2.	1
Melt mass-flow rate	§ 5.2.1.4	§ 6.3.	1
Volatile content	§ 5.2.1.5	§ 6.4.	1
Water content	§5.2.1.6	§6.5.	1
Pigment dispersion	§ 5.1.8.	As per Annex E of IS 14885	1
Thermal stability	§ 5.2.7.	§ 6.6	1

Supplementary Procedure for Type approval of Polyethylene Pipes for Underground Gas Networks	DOCUMENT NO.	Rev
	11-0269-02-07-02-007	0
	Page 11 of 14	

1.2.2 YELLOW RESIN OR RESIN USED FOR COEXTRUDED MARKING

TABLE OF TESTS ON MATERIALS

Test	Quality criterion as per specification 11-0269-02-07-02-001	Inspection method as per specification 11-0269-02-07-02-001	Number of samples per batch
Density	§ 5.2.1.3	§ 6.2.	1
Melt mass-flow rate(M5l)	§ 5.2.1.4	§ 6.3.	1
Volatile content	§ 5.2.1.5	§ 6.4.	1
Water content	§5.2.1.6	§6.5.	1
Pigment dispersion	§ 5.1.8.	As per Annex E of IS 14885	1
Thermal stability	§ 5.2.7.	§ 6.6	1

1.2.2.1 TESTING OF PIPES

The following tests and checks must be carried out on representative samples of pipes manufactured using the same batch of raw material on a given extrusion line at its maximum rate.

	Supplementary Procedure for Type approval of Polyethylene Pipes for Underground Gas Networks	DOCUMENT NO.	Rev
		11-0269-02-07-02-007	0
		Page 12 of 14	

TABLE OF TESTS ON PIPE SAMPLES

Test	Quality criterion as per specification 11-0269-02-07-02-001	Test method as per specification 11-0269-02-07-02-001	Number of samples per batch	Number of test specimen	
				Per sample	Per batch
Appearance-dimensions-marking					
Internal stresses	§ 5.2.2.1.	§ 6.8	2	3 from the same pipe	6
Determination of Traction Characteristics	§ 5.2.2.5.	§ 6.12	2	3 from the same pipe	6
Melt mass-flow rate	§ 5.2.1.4.	§ 6.3	2	1 from the same pipe	2
Resistance to internal hydraulic pressure at 20°C	§ 5.2.2.2.	§ 6.9	1	2 test specimens (+ 2 reserves) 1 test specimen per pipe	4
at 80°C			1	2 test specimens (+ 2 reserves) 1 test specimen per pipe	4
Weldability (applicable to pipes with external diameter of 90 mm or more)	§ 5.2.2.6	§ 6.13	2	2 sections of different pipes welded end to end	4
Appearance and dimensions	§ 5.2.2.6	§ 6.13.1			
Resistance to internal hydraulic pressure at 20°C	§ 5.2.2.2	§ 6.13.2. + 6.9.	1	1 test specimen of welded pipes 1 test specimen of welded pipes	
at 80°C			1		
Traction on welded pipe	§ 5.2.2.6	§ 6.13.3	1	1 welded sample	2
Resistance to growth of cleavage fracture (applicable to pipes with external diameters of 110 mm or more) (1)	§ 5.2.2.4.	§ 6.11	1	4 section of the same pipe	4
Thermal stability of PE	§ 5.2.1.7.	§ 6.6	1		1
Resistance to atmospheric influence	§ 5.2.1.8.	§ 6.7	under study		

The pipe is considered to be resistant when the length of the crack formed during the test remains smaller than the nominal diameter of the pipe. Failing this, the rate of growth of the crack must steadily decline.

Supplementary Procedure for Type approval of Polyethylene Pipes for Underground Gas Networks	DOCUMENT NO.	Rev
	11-0269-02-07-02-007	0
	Page 13 of 14	

APPENDIX 3—SEALS

Seals must comply with the requirements defined in section 8.4. of specification 11-0269- 02-07-02- 001
The manufacturer shall supply drawings stating seal tolerances and the material from which the seals are made.

	Supplementary Procedure for Type approval of Polyethylene Pipes for Underground Gas Networks	DOCUMENT NO.	Rev
		11-0269-02-07-02-007	0
		Page 14 of 14	

**AAVANTIKA GAS LIMITED
CITY GAS DISTRIBUTION PROJECT**



POWDER COATING					CLIENT JOB NO.	-
					TOTAL SHEETS	05
DOCUMENT NO	11	0269	02	07	02	014

--	--	--	--	--	--

0	18.10.09	ISSUED FOR CLIENT COMMENTS		AP	SB SB
A	16.10.09	ISSUED FOR IDC		AP	SB SB
REV	DATE	DESCRIPTION		PREP	CHK APPR

PURE POLYESTER POWDER COATING

	POWDER COATING	DOCUMENT NO.	Rev
		11-0269-02-07-02-014	0
		Page 2 of 5	

TABLE OF CONTENT

1.0 SCOPE 4

2.0 SPECIFICATION FOR POWDER COATING..... 4

3.0 TESTING 4

4.0 MARKING..... 5

5.0 INSPECTION / DOCUMENTS 5

	POWDER COATING	DOCUMENT NO.	Rev
		11-0269-02-07-02-014	0
		Page 3 of 5	

1.0 SCOPE

This Specification specifies the requirements for powder coating (Pure Polyester) of GI Pipes & fitting suitable to use for carrying Natural Gas directly expose to sunlight.

2.0 SPECIFICATION FOR POWDER COATING

Powder Material: Pure Polyester.
Application : Electrostatic Spraying (40 — 90 KV Manual / Automatic)
Backing Schedule: 180⁰ C to 200⁰C for 10 mm (Metal Temperature)
Coating Thickness: 50-60 Microns

3.0 TESTING

Film Type	:	Glossy/Satin	
Gloss 60°	:	86-95%	
Cross Hatch Adhesion (ASTM D- 5870)	:	GT=0/100	
Cylindrical bending Test (ASTM D -522) 5mm Rod dia.	:	Passes	
Enrichsen cupping (min)	:	8 Passes	
Pencil Hardness. (mm)	:	2H	
Scratch Resistance (Kg. Mm)	:	3	
Impact Resistance	:	Direct	150
Kg.Min(ASTM D-2794)	:	Indirect	150
Salt Spray Resistance (ASTM B—117)	:	1000 Hrs (min)	
Porosity (DIN 53161)	:	Passes	
Humidity Resistance	:	1000 Hrs (min)	

	POWDER COATING	DOCUMENT NO.	Rev
		11-0269-02-07-02-014	0
		Page 4 of 5	

4.0 MARKING

Each fitting shall be embossed with manufacture's name or trademark and the size designation.

Each packing containing fittings shall carry the following stamped or written by indelible ink.

- a) Manufacturers name or trade mark
- b) Designation of fitting.
- c) Lot number.

Each fitting conforming to this standard shall also be marked with BIS standard mark.

5.0 INSPECTION / DOCUMENTS

- i. Inspection shall be carried out as per OWNER Technical Specification.
- ii. OWNER representative or Third Party Inspection Agency appointed by OWNER shall carry out stage wise inspection during manufacturing/final inspection.
- iii. Vendor shall furnish all the material test certificates, proof of approval/ licence from specified authority as per specified standard, if relevant, internal test inspection reports as per OWNER Tech Spec. &- specified code for 100% material, at the time of final inspection of each supply lot of material.
- iv. Even after third party inspection, OWNER/ OWNER REPRESENTATIVE reserves the rights to select a sample of fittings randomly from each manufacturing batch & have these independently tested. Should the results of these tests fall outside the limits specified in OWNER technical specification, then OWNER/ OWNER REPRESENTATIVE reserves the rights to reject all production supplied from the batch.

(ASTM D- 2247)

Weathering : 60 —70%

Gloss retention after 1000 Hrs.
(suntest with water immersion,
Xenon 150K.lux)

Colour : Light colour as approved by OWNER/CONSULTANT

	POWDER COATING	DOCUMENT NO.	Rev
		11-0269-02-07-02-014	0
		Page 5 of 5	

	AAVANTIKA GAS LIMITED CITY GAS DISTRIBUTION PROJECT	
--	--	---

POLYETHYLENE PIPES					CLIENT JOB NO.	-
					TOTAL SHEETS	05
DOCUMENT NO	11	0269	02	07	02	024

--	--	--	--	--	--

0	18.10.09	ISSUED FOR CLIENT COMMENTS		AP	SB SB
A	16.10.09	ISSUED FOR IDC		AP	SB SB
REV	DATE	DESCRIPTION		PREP	CHK APPR

TECHNICAL SPECIFICATION FOR POLYETHYLENE PIPES

	Polyethylene Pipes	DOCUMENT NO.	Rev
		11-0269-02-09-02-024	0
		Page 2 of 5	

TABLE OF CONTENTS

1.0	INTRODUCTION & SCOPE	4
2.0	DEFINITIONS	4
3.0	PIPE SIZES	4
4.0	LENGTH OF PIPES.....	4
5.0	COLOUR	4
6.0	MARKING.....	5
7.0	HANDLING AND STORAGE	5
8.0	QUALITY ASSURANCE (QA).....	5

	Polyethylene Pipes	DOCUMENT NO.	Rev
		11-0269-02-09-02-024	0
		Page 3 of 5	

1.0 INTRODUCTION & SCOPE

The present Specification relates to the manufacture of “Polyethylene Line Pipes” for the Aavantika Gas City Gas Distribution Project.

The present Specification has to be read in conjunction with Technical Specifications 011-269-02-07-02-001, 002, 003, 004.

The present specification confirms, completes or modifies certain sections/paragraphs of the said General Technical Specifications.

2.0 DEFINITIONS

Owner/Purchaser/Client/Owner Representative: Company: means AAVANTIKA GAS LIMITED
Manufacturer means the Manufacturer of the pipes as well as its sub-contractor(s). Third Party Inspection Agency means the Inspection Agency to be appointed by AGL Bidder means the party quoting for the pipes.

3.0 PIPE SIZES

(REF. CL. 5.2.3.1 OF 011-269-02-07-02-001)

<u>Nominal Dia (Di)</u>	<u>Thickness</u>	<u>Material</u>
20mm	SDR11	PE100 Polyethylene
32mm	SDR11	PE100 Polyethylene
63mm	SDR11	PE100 Polyethylene
125mm	SDR17	PE100 Polyethylene

4.0 LENGTH OF PIPES

(REF. CL. 8.2 OF 011-269-02-07-02-001)

The required minimum lengths are as follows:

<u>Nominal Dia</u>	<u>Lengths</u>
20 mm	200 mtrs
32 mm	200 mtrs
63mm	100 mtrs
125mm	50 mtrs

5.0 COLOUR

(REF. CL. 5.2.1.2 OF 011-269-02-07-02-001)

The pipe shall be of ORANGE colour.



6.0 MARKING

Owner's/Owner Representative name as AGL be marked on each pipe.

7.0 HANDLING AND STORAGE

Packaging shall be done in Hessian cloth (Jute) to avoid direct sunlight and facilitate out-door storage.

8.0 QUALITY ASSURANCE (QA)

(REF. CL. 3.2 OF 011-269-02-07-02-003)

Manufacturer to submit QA system for the approval of Owner /Owner Representative.

	Polyethylene Pipes	DOCUMENT NO.	Rev
		11-0269-02-09-02-024	0
		Page 5 of 5	

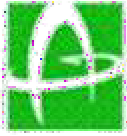

**CITY GAS DISTRIBUTION PROJECT
TENDER FOR I & C PNG CONNECTIONS**

ANNEXURE # 1

TOOLS & EQUIPMENT TO BE PROVIDED BY CONTRACTOR FOR GI WORK

S.NO.	HAND TOOLS DESCRIPTION	PER TECHNICIAN	PER TEAM
1	Pipe wrench 250 mm	1	4
2	Pipe wrench 350 mm	1	4
3	Pipe wrench 450 mm	-	2
4	Adjustable spanner 50 mm	-	4
5	Adjustable spanner 150 mm	1	2
6	Adjustable spanner 250 mm	1	2
7	Set of combination spanner 3/16"-11/4" AF	1	1
8	Set of combination spanners 5mm - 30mm	1	1
9	Large tool boxes	1	2
10	Set flat-headed screw drivers	1	2
11	Set Philips screw drivers	1	2
12	Small hammer	1	2
13	Combination pliers/mole grips	1	2
14	Set of files	1	2
15	Drill bits for 1" pipe	-	2
16	Stocks and dies for NPT threading 1/2", 3/4", GI Pipe	-	3
17	Blowtorch	-	1
18	Soldering iron	-	2
19	Copper Pipe Bending Machine	-	2
20	Hand drill 3/8" chuck	-	2
21		-	
22	Spare blades	4	4
23	Battery powered torches	2	2
24	Measuring tape 30 m	1	2
25	Wire brush	1	2
26	Portable pipe vice & tripod	-	2
27	Set steel twist drills 0.5-2.0 mm (for appliance conversion)	-	1
28	Set steel twist drills 1mm-10mm	-	2
29	Set masonry drills 1mm-10mm	1	2
30	Graphite based grease	As required	As required

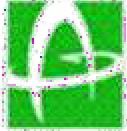

**CITY GAS DISTRIBUTION PROJECT
TENDER FOR PNG I&C CONNECTIONS**

31	Lubricating oil	As required	As required
32	Hand cleaner	As required	As required
33	Copper pipe Cutter 12mm	-	4
34	GI Pipe Cutters ½"	-	2
	Gas Detection Equipment Power	As required	-
	Generator 2.5 KVA Pressure	1	-
	Gauge (0-10 bar) Pressure Gauge	2	4
	(0-4 bar) Diaphragm Gauge (0-400 m bar) Manometer (0-150 m bar)	2 1 1	8 2 1
35	Automatic Thread cutting machine	-	2
36	GI Pipe Cutter	-	2
37	Welding Equipment	01 set per site	01 set per site
38	Full Body Safety Harness like PETZL or Equivalent	03 set per site	03 set per site
39	Motorized Suspended Platform	As required	As required

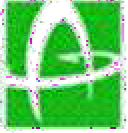

**CITY GAS DISTRIBUTION PROJECT
TENDER FOR PNG I&C CONNECTIONS**

Technical Specification of GI PIPES



**CITY GAS DISTRIBUTION PROJECT
TENDER FOR PNG I&C CONNECTIONS**

TABLE OF CONTENTS

1.0	INTRODUCTION AND SCOPE	1
2.0	DEFINITIONS.....	1
3.0	MATERIAL	1
4.0	DIMENSIONS, THICKNESS & DIMENSIONAL TOLERANCES	1
5.0	END CONNECTION OF PIPE.....	1
6.0	FREEDOM FROM DEFECTS.....	2
7.0	GALVANIZING.....	2
8.0	PRESSURE TEST	2
9.0	MARKING	2
10.0	INSPECTION / DOCUMENTS.....	3
11.0	PACKAGING	3

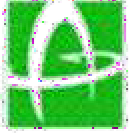

CITY GAS DISTRIBUTION PROJECT TENDER FOR PNG I&C CONNECTIONS

1.0 INTRODUCTION AND SCOPE

AAVANTIKA GAS LTD. (AGL) plans to augment PNG network. It supplies natural gas to domestic & commercial consumers in the city of Indore, Ujjain & Gwalior.

This present document covers the technical specification for the procurement of GI Pipes used in high pressure natural gas transportation and distribution systems. It describes the general requirements, controls, tests, QA/QC examination and final acceptance criteria which needs to be fulfilled.

This specification covers the requirements for GI pipes of heavy steel tube. Unless modified by this specification, requirements of IS 1239 (Part-I): 2004 (Latest edition) shall be valid.

2.0 DEFINITIONS

Owner	Shall mean Aavantika Gas Ltd. (AGL).
Manufacturer	Means the Manufacturer of the GI pipe.
PTS	Means the present <<Particular Technical Specification>>and all its appendix, if any.
Third Party Inspection Agency	Means the Inspection Agency to be appointed by AGL.
GTS	Means the present <<General Technical Specification>> and its entire appendix, if any.

3.0 MATERIAL

The material used for the manufacturing of GI pipes confirming to IS 1239 (Part -1): 2004 (Latest edition).

4.0 DIMENSIONS, THICKNESS & DIMENSIONAL TOLERANCES

The dimensions & nominal mass of tubes shall be in accordance with Table 5 subject to the tolerances permitted in CL.8.1 & 9 of IS 1239 (Part-I) : 2004 (Latest edition). Length of each pipe shall be 6 mtrs with. + 6, - 0 mm tolerance. However, pipe length shall be considered 6 m. only for measurement / payment purpose.

Nominal Diameter DN	25 mm	20 mm
Grade	Heavy	Heavy
Outer Dia. (Max. / Min.)	34.2 mm / 33.3 mm	27.3 mm / 26.5 mm
Thickness (mm)	4.0	3.2
Nominal weight (Kg / m)	2.93	1.87

5.0 END CONNECTION OF PIPE

GI Pipes shall be supplied with plain end.

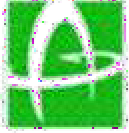

CITY GAS DISTRIBUTION PROJECT TENDER FOR PNG I&C CONNECTIONS

6.0 FREEDOM FROM DEFECTS

On visual examination the outside & inside surfaces of pipes shall be smooth & free from defects such as cracks etc.

7.0 GALVANIZING

- * Pipes shall be galvanized to meet the requirement of IS: 4736 – 1986 with latest amendment.
- * Zinc conforming to any grade specified in IS: 13229- 1991 with latest amendment shall be used for the purpose of galvanizing.
- * Galvanizing bath: The molten metal in the galvanizing bath shall contain not less than 98.5% by mass of zinc.
- * Mass of zinc coating: Minimum mass of zinc coating determined as per IS: 6745 shall be 360 gms/m^2 .
- * Uniformity of galvanized coating: The galvanized coating when determined on a 100 mm long test piece in accordance with IS 2633: 1986 with latest amendment shall withstand 5 one – minute dips.
- * Freedom from defect: The zinc coating on internal & external surfaces shall be uniform adhered, reasonably smooth & free from such imperfections as flux, ash & drop inclusions, bare patches, black spots, pimples, lumpiness runs, rust stains, bulky white deposits & blisters. Rejection & acceptance for these defects shall be as per Appendix - A of IS 2629: 1985 with latest amendments.
- * Samplings

All materials of the same type in coating bath having uniform coating characteristics shall be grouped together to continue a lot. Each lot shall be tested separately for the various requirements of the specification. The number of units to be selected from each lot for this purpose shall be IS: 4711 1995 with latest amendment.

The sample selected according to Clause 6.1 & 6.2 of IS: 4736 – latest edition.

The sample found conforming to above requirements shall then be tested for mass of zinc coating in accordance with Clause 5.1 of IS: 4736 – 1986 with latest amendment.

Criteria for conformity: As per IS: 4736 – 1986 with latest amendments.

8.0 PRESSURE TEST

Hydrostatic pressure test shall be carried out at a pressure of 5 Mpa for the duration of at least 3 second and shall not show any leakage in the pipe. Vendor to submit the internal pressure test certificate for the same. Owner Representative or Third party Inspection Agency appointed by Owner shall witness finish goods testing as per the sample procedure specified in IS: 1239 (Part-1) – latest edition.

9.0 MARKING

Each pipe shall be embossed with AGL's logo, manufacturer's name or trademark, size designation, class of pipe at the interval of not more than 1 meters.

Each packing containing pipes shall carry the following embossed, stamped or written by indelible ink.

- Manufacturers name or trademark.
- Class of pipe – Heavy.
- Indian standard mark (ISI).
- Lot number / Batch no. of production.

Each pipe conforming to this standard shall also be marked with BIS standard mark.

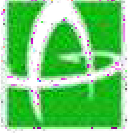

**CITY GAS DISTRIBUTION PROJECT
TENDER FOR PNG I&C CONNECTIONS**

10.0 INSPECTION / DOCUMENTS

Inspection shall be carried out as per Owner Technical Specification.

Owner Representative or Third Party Inspection Agency appointed by Owner shall carry out stage wise inspection during manufacturing / final inspection.

The manufacturer shall have a valid licence to use ISI monogram for manufacturing of pipe in accordance with the requirement of IS 1239:2004 (Latest Edition).

Vendor shall furnish all the material test certificates, proof of approval / license from specified authority as per specified standard, if relevant, internal test / inspection reports as per Owner Tech. Spec. & specified code for 100% material, at the time of final inspection of each supply lot of material.

For any control, test or examination required under the supervision of TPIA/Owner/Owner's representative, latter shall be informed in writing one (1) week in advance by vendor about inspection date and place along with production schedule.

Even after third party inspection, Owner reserves the right to select a sample of pipes randomly from each manufacturing batch & have these independently tested. Should the results of these tests fall outside the limits specified in Owner technical specification, then Owner reserves the right to reject all production supplied from the batch.

11.0 PACKAGING

Packing size to be mentioned to ensure uniformity in delivery conditions of the material being procured. Bidder shall submit the packaging details during QAP and also complied with at the time of delivery.

Σ Σ Σ

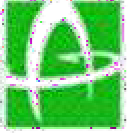

**CITY GAS DISTRIBUTION PROJECT
TENDER FOR PNG I&C CONNECTIONS**

**TECHNICAL SPECIFICATION OF FORGED FITTINGS (WROUGHT
STEEL FITTINGS) FOR USE AT PRESSURE UP TO 500 MBAR (G)**

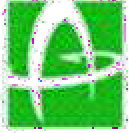

**CITY GAS DISTRIBUTION PROJECT
TENDER FOR PNG DOMESTIC CONNECTIONS**

TABLE OF CONTENTS

1.0	INTRODUCTION AND SCOPE	1
2.0	DEFINITIONS.....	1
3.0	MATERIAL	1
4.0	DIMENSIONS & DIMENSIONAL TOLERANCES	1
5.0	THREADS	1
6.0	FREEDOM FROM DEFECTS.....	1
7.0	GALVANIZING.....	2
8.0	PRESSURE TEST	2
9.0	COMPRESSION TEST	2
10.0	SAMPLING	2
11.0	MARKING.....	2
12.0	PACKAGING	3
13.0	INSPECTION / DOCUMENTS.....	3



CITY GAS DISTRIBUTION PROJECT TENDER FOR PNG I&C CONNECTIONS

1.0 INTRODUCTION AND SCOPE

AAVANTIKA GAS LTD. (AGL) plans to augment PNG network. It supplies natural gas to domestic & commercial consumers in the city of Indore, Ujjain & Gwalior.

This specification covers the requirements for Wrought Steel Fittings for Natural Gas for use at pressures up to 500 mbar (g). Unless modified by this specification, all the requirements of IS 1239 Part 2: 1992 and the latest editions of the standards mentioned herein this specification, including all revisions, shall apply.

2.0 DEFINITIONS

Owner	Shall mean Aavantika Gas Ltd. (AGL).
Manufacturer	Means the Manufacturer of the GI fittings.
PTS	Means the present <<Particular Technical Specification>>and its appendix, if any.
Third Party Inspection Agency	Means the Inspection Agency to be appointed by AGL.
GTS	Means the present <<General Technical Specification>> and its entire appendix, if any.

3.0 MATERIAL

The material used for the manufacturing of wrought steel fittings shall confirm to IS 1387: 1967 generally, and IS 1239 Part 2: 1992.

4.0 DIMENSIONS & DIMENSIONAL TOLERANCES

4. Dimensions of various types of fittings shall be as specified in the table 1 to 31 of IS 1239 Part 2: 1992.
- Wall thickness on fittings & tolerances on them shall be as given in table 1 to 31 of IS 1239 Part 2: 1992.
- In case of reducing fittings, the dimensions at each outlet shall be those appropriate to the nominal size of the outlet.

5.0 THREADS

- Outlet of fittings shall be threaded to dimensions & the tolerances as specified in IS 554: 1999.
 - All internal & external threads shall be tapered.
 - After threading, the pipe body may be hot dip galvanized as per normal practice followed by cold galvanizing (spraying) of the threaded portions. The threaded portions shall be protected using end caps, etc.
- IV. For checking conformity of threads gauging practice in accordance with IS 8999: 2003 shall be followed.
- Chamfering: The outlet of fittings shall have chamfer. The chamfer shall have an included angle of 90 ± 50 for internal threads & 700 ± 100 for external threads.

6.0 FREEDOM FROM DEFECTS

On visual examination the outside & inside surfaces of fittings shall be smooth & free from defects such as cracks, injurious flows, fine sand depth, etc. Other workmanship shall be as per Clause 14 of IS 1239 Part 2: 1992.

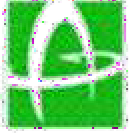

CITY GAS DISTRIBUTION PROJECT TENDER FOR PNG I&C CONNECTIONS

7.0 GALVANIZING

5. Fittings shall be galvanized to meet the requirements of IS 4759: 1996.
6. Zinc conforming to any grade specified in IS 209: 1992 or IS 13229: 1991 shall be used for the purpose of galvanizing.
7. **Galvanized Bath:** The molten metal in the galvanizing bath shall contain not less than 98.5% by mass of zinc.
8. **Coating requirements:** Mass of coating shall be 610 gms/m^2 . In case of pipe nipples (manufactured in accordance with the requirements of IS 1239 Part 1: 2004), the mass of coating of 400 gms/m^2 shall also be acceptable.
9. **Freedom from defects:** The zinc coating shall be uniformly adhered, reasonably smooth & free from such imperfections as flux, ash bare patches, black spots, pimples, lumpiness runs, rust strains, bulky white deposits & blisters; otherwise the pipes shall be liable for rejection.
10. **Sampling Plan for galvanizing**

All materials of the same type in a coating bath having uniform coating characteristics shall be grouped together to constitute a lot. Each lot shall be tested separately for the various requirements of the specification

The number of units to be selected from each lot for this purpose shall be as given in Table 2 of IS 4759: 1996.

The sample selected according to Column 1 & 2 of Table 2, IS 4759: 1996 shall be tested for visual requirements as per Para 8 of IS 4759: 1996. Vendor shall have appropriate correspondence between galvanizing lot number and pipe manufacturing lot number for identification / traceability.

The sample found conforming to above requirements shall then be tested for mass of zinc coating in accordance with Clause 9.2 of IS 4759: 1996.

- Criteria for conformity: As per Clause 8.3 of IS 4759: 1996.

Test procedure shall be as per Clause 9 of IS 4759: 1996. All galvanizing test results shall be included in the Manufacturer's Test Certificate.

8.0 PRESSURE TEST

Pneumatic pressure test shall be carried out on each & every fittings as per procedure given in IS 1239 Part 2: 1992.

9.0 COMPRESSION TEST

As per IS 1239 Part 2: 1992.

10.0 SAMPLING

Owner Representative of Third Party Inspection Agency appointed by Owner shall witness the tests as per procedure for sampling plan given in IS 4711: 1974. However, vendor to perform 100% inspection of visual, dimensional & pressure test. Vendor shall furnish Internal test certificates at the time of final inspection to the Owner.

11.0 MARKING

Each fitting shall be embossed with AGL's logo, manufacturer's name or trademark and the size designation.

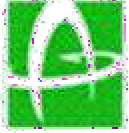

**CITY GAS DISTRIBUTION PROJECT
TENDER FOR PNG I&C CONNECTIONS**

Each packing containing fittings shall carry the following embossed, stamped or written by indelible ink.

- Manufacturer's name or trade mark.
- Designation of fittings.
- Lot number.

Each fitting conforming to this standard shall also be marked with BIS standard mark.

12.0 PACKAGING

Packing size to be mentioned to ensure uniformity in delivery conditions of the material being procured. Packing size shall be approved by owner / owner's representative before packing the material. The vendor shall submit the packaging details during QAP and also complied with at the time of delivery.

13.0 INSPECTION / DOCUMENTS

- Inspection shall be carried out as per Owner Technical Specification.
- Owner Representative or Third Party Inspection Agency appointed by Owner shall carry out stage wise inspection during manufacturing / final inspection.
- Vendor shall furnish all the material test certificates, proof of approval / licence from specified authority as per specified standard, if relevant, internal test / Inspection reports as per Owner Tech Spec. & specified code for 100% material, at the time of final inspection of each supply lot of material.
- Even after third party inspection, Owner reserves the rights to select a sample of fittings randomly from each manufacturing batch & have these independently tested. Should the results of these tests fall outside the limits specified in Owner technical specification, then Owner reserves the rights to reject all production supplied from the batch.

Σ Σ

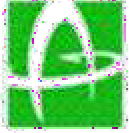

**CITY GAS DISTRIBUTION PROJECT
TENDER FOR PNG I&C CONNECTIONS**

Technical Specification of GI FITTINGS

TABLE OF CONTENTS

1.0	INTRODUCTION AND SCOPE.....	1
2.0	DEFINITIONS	1
3.0	MATERIAL	1
4.0	DIMENSIONS & DIMENSIONAL TOLERANCES.....	1
5.0	WEIGHT	1
6.0	THREADS.....	1
7.0	FREEDOM FROM DEFECTS.....	2
8.0	GALVANIZING	2
9.0	PRESSURE TEST.....	2
10.0	COMPRESSION TEST	2
11.0	SAMPLING.....	2
12.0	MARKING	3
13.0	PACKAGING	3
14.0	INSPECTION / DOCUMENTS	3

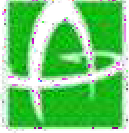

CITY GAS DISTRIBUTION PROJECT TENDER FOR PNG I&C CONNECTIONS

1.0 INTRODUCTION AND SCOPE

AAVANTIKA GAS LTD. (AGL) plans to augment PNG network. It supplies natural gas to domestic & commercial consumers in the city of Indore, Ujjain & Gwalior.

This present document covers the technical specification for the procurement of GI fittings used in high pressure natural gas transportation and distribution systems. It describes the general requirements, controls, tests, QA/QC examination and final acceptance criteria which need to be fulfilled.

This specification covers the requirements for Malleable Cast Iron Fittings unless modified by this specification, requirements of IS 1879 – latest edition shall be valid.

2.0 DEFINITIONS

Owner	Shall mean Aavantika Gas Ltd. (AGL).
Manufacturer	Means the Manufacturer of the GI fittings.
PTS	Means the present <<Particular Technical Specification>>and its appendix, if any.
Third Party Inspection Agency	Means the Inspection Agency to be appointed by AGL.
GTS	Means the present <<General Technical Specification>> and its entire appendix, if any.

3.0 MATERIAL

The material used for the manufacturing of GI fittings shall conform to ISI 14329 – 1995 with latest amendments Grade BM 300.

4.0 DIMENSIONS & DIMENSIONAL TOLERANCES

- i. Dimensions of various types of fittings shall be as specified in sections 2 to 10 of IS 1879 – 1987 with latest amendments, as applicable.
- ii. Wall thickness of fittings and tolerances on them shall be as given in Table 1.2 of S 1879 – 1987 with latest amendments,
- iii. In case of reducing fittings, the dimensions at each outlet shall be those appropriate to the nominal size of the outlet.
- iv. Elbows, Tees, Sockets and caps shall be of reinforced type.

5.0 WEIGHT

Weights of various types of fittings shall be as specified in sections 2 to 10 of S 1879 – 1987 with latest amendments, as applicable.

6.0 THREADS

- Threads shall be NPT type and conforming to ASME B1.20.1.
- Outlets of fittings shall be threaded to dimensions & the tolerances as specified in ASME B1.20.1.
- All internal & external threads shall be tapered.
- For checking conformity of threads gauging practice in accordance with ASME B1.20.1 shall be followed.
- Chamfering: The outlet of fittings shall have chamfer.

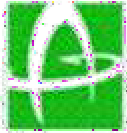

CITY GAS DISTRIBUTION PROJECT TENDER FOR PNG I&C CONNECTIONS

7.0 FREEDOM FROM DEFECTS

On visual examination, the outside & inside surfaces of fittings shall be smooth & free from any defects such as cracks, injurious flaws, fine sand depth etc.

8.0 GALVANIZING

- i. Fittings shall be galvanized to meet the requirement of IS: 4759 – 1996 with latest amendments.
- ii. Zinc conforming to any grade specified in IS: 13229-1991 with latest amendments shall be used for the purpose of galvanizing.
- iii. Galvanizing bath: The molten metal in the galvanizing bath shall contain not less than 98.5% by mass of zinc.
- iv. Coating requirements: Mass of coating shall be 610 - 700 gms/m².
- v. Freedom from defect: The zinc coating shall be uniform adhered, reasonably smooth & free from such imperfections as flux, ash bare patches, black spots, pimples, lumpiness runs, rust stains, bulky white deposits & blisters.
- vi. Samplings
 - a) All materials of the same type in coating bath having uniform coating characteristics shall be grouped together to continue a lot. Each lot shall be tested separately for the various requirements of the specification. The number of units to be selected from each lot for this purpose shall be given in Table 2 of IS 4759 – latest edition.
 - b) The sample selected according to Column 1 & 2 of Table 2, IS: 4759 – latest edition shall be tested for visual requirements as per Clause 6.2 of IS:4759 – latest edition
 - c) The sample found conforming to above requirements shall then be tested for mass of zinc coating in accordance with Clause 9.2 of IS: 4759 – latest edition.
 - d) Criteria for conformity: As per Clause 8.3 of IS: 4759-latest edition.
 - e) Test procedure shall be as per Clause 9 of IS: 4759-latest edition.

9.0 PRESSURE TEST

Vendor shall carry out pneumatic pressure test as per Clause 11.1b of 1879 – 1987 with latest amendments on each & every fittings. Vendor to submit the Internal Quality control certificate for the same. Owner shall witness pneumatic testing as per the sampling procedure specified in 1879 – 1987 with latest amendments.

10.0 COMPRESSION TEST

This test shall be conducted to judge the malleability of the pipe fittings & shall be carried out as per Clause 12 of 1879 – 1987 with latest amendments.

11.0 SAMPLING

Owner Representative of Third Party Inspection Agency appointed by Owner shall witness the tests as per clause 14 of 1879 – 1987 with latest amendments. However, vendor to perform 100% inspection of visual, dimensional & pressure test. Vendor shall furnish Internal test certificates at the time of final inspection to the
Owner.

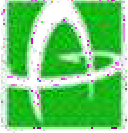

**CITY GAS DISTRIBUTION PROJECT
TENDER FOR PNG I&C CONNECTIONS**

12.0 MARKING

Each fitting shall be embossed with AGL's logo, manufacturer's name or trademark and the size designation.

Each packing containing fittings shall carry the following embossed, stamped or written by indelible ink.

- Manufacturer's name or trade mark.
- Designation of fittings.
- Lot number.

Each fitting conforming to this standard shall also be marked with BIS standard mark.

13.0 PACKAGING

Packing size to be mentioned to ensure uniformity in delivery conditions of the material being procured. Packing size shall be approved by owner / owner's representative before packing the material. The vendor shall submit the packaging details during QAP and also complied with at the time of delivery.

14.0 INSPECTION / DOCUMENTS

- Inspection shall be carried out as per Owner Technical Specification.
- Owner Representative or Third Party Inspection Agency appointed by Owner shall carry out stage wise inspection during manufacturing / final inspection.
- Vendor shall furnish all the material test certificates, proof of approval / licence from specified authority as per specified standard, if relevant, internal test / Inspection reports as per Owner Tech Spec. & specified code for 100% material, at the time of final inspection of each supply lot of material.
- Even after third party inspection, Owner reserves the rights to select a sample of fittings randomly from each manufacturing batch & have these independently tested. Should the results of these tests fall outside the limits specified in Owner technical specification, then Owner reserves the rights to reject all production supplied from the batch.

Σ Σ



**CITY GAS DISTRIBUTION PROJECT
TENDER FOR PNG I&C CONNECTIONS**

TECHNICAL SPECIFICATION FOR APPLIANCE BALL VALVES

	APPLIANCE BALL VALVES	DOCUMENT NO.	Rev
		11-0269-01-07-02-035	0
		Page 1 of 3	

TABLE OF CONTENTS

1.0 SCOPE4
2.0 DESIGN CONDITIONS.....4
3.0 VALVE DATA.....4

	APPLIANCE BALL VALVES	DOCUMENT NO.	Rev
		11-0269-01-07-02-035	0
		Page 2 of 3	

1.0 SCOPE

This specification refers to the requirement of Appliance Valve suited to connect flexible rubber hose for supply of natural gas to Industrial and commercial consumers.

2.0 DESIGN CONDITIONS

Pressure (mili Barg) : 35
Temperature(0C) : 0 – 45

3.0 VALVE DATA

Construction design : ANSI B 16.33

Type : Full Bore – Open/ Close at 90⁰.

End connection : NPT Female (conforming to ANSI B 1.20.1). Female as an inlet (1/2”) & the Outlet shall be having Ni/Cr plated brass or steel nozzle to suit Flexible Rubber Tube as per IS 10908.

Body material : Hot Pressed / Forged Brass, Nickel / Chrome Plated.

Ball material : Hard Nickel / Chrome Plated, Hot Pressed / Machined Brass Bars with Teflon Seat.

Others : With Mechanical Operating/Knob/lever.

Mechanical Strength : -The body of the valve shall withstand without Deformation or leakage a min torque of 125 Nm.

- Valve shall be capable of withstanding deformation or leakage 125 Nm bending moment or an angular displacement of 10⁰ whichever occurs first, if applied to a pipe connected to the valve.

-The valves shall be capable of withstanding 25 Nm impact without breakage or leakage.

Testing : Hydro Test & Leak Test

- Leak test shall be carried out either with nitrogen or air

Page 48 of 111	APPLIANCE BALL VALVES	DOCUMENT NO.	Rev
		11-0269-01-07-02-035	0
		Page 3 of 3	

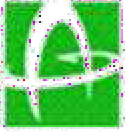

**CITY GAS DISTRIBUTION PROJECT
TENDER FOR PNG I&C CONNECTIONS**

TECHNICAL SPECIFICATION FOR ISOLATION BALL VALVES

	ISOLATION BALL VALVES	DOCUMENT NO.	Rev
		11-0269-01-07-02-034	0
		Page 1 of 3	

TABLE OF CONTENTS

1.0 SCOPE 4

2.0 DESIGN CONDITIONS..... 4

3.0 VALVE DATA..... 4

	ISOLATION BALL VALVES	DOCUMENT NO.	Rev
		11-0269-01-07-02-034	0
		Page 2 of 3	

1.0 SCOPE

This specification refers to the requirement of Isolation Ball Valves to be installed before Meter for the supply of natural gas to Industrial and Commercial consumers.

2.0 DESIGN CONDITIONS

Pressure (Barg) : 4.0
Temperature (⁰C) : 0 – 45

3.0 VALVE DATA

Construction design : ANSI B 16.33

Type : Full Bore – Open/ Close at 90⁰.

End connection : NPT Female (conforming to ANSI B 1.20.1)

Body material : Hot Pressed / Forged Brass, Nickel / Chrome Plated.

Ball material : Hard Nickel / Chrome Plated, Hot Pressed / Machined Brass Bars with Teflon Seat.

Others : With Operating Knob and locking arrangement with sealing Wire.

Mechanical Strength : -The body of the valve shall withstand without Deformation or leakage a min torque of 125 Nm.

- Valve shall be capable of withstanding deformation or leakage 340 Nm bending moment or an angular displacement of 10⁰ whichever occurs first, if applied to a pipe connected to the valve.

-The valves shall be capable of withstanding 25 Nm impact without breakage or leakage.

Testing : Hydro Test Pressure
Leak test

- Leak test shall be done either with nitrogen or Air at design pressure.

- Hydrotest to be done at 1.5 times the design pressure.

	ISOLATION BALL VALVES	DOCUMENT NO.	Rev
		11-0269-01-07-02-034	0
		Page 3 of 3	



**CITY GAS DISTRIBUTION PROJECT
TENDER FOR PNG I&C CONNECTIONS**

TECHNICAL SPECIFICATION OF HEALTH, SAFETY & ENVIRONMENT

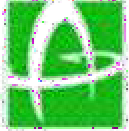

**CITY GAS DISTRIBUTION PROJECT
TENDER FOR PNG I&C CONNECTIONS**

TABLE OF CONTENTS

1.0	SCOPE	1
1.1	APPLICABLE SYSTEMS AND PROCEDURES	1
2.0	REFERENCES	1
3.0	RESPONSIBILITY & ORGANISATION	1
4.0	GENERAL REQUIREMENT	2
5.0	TRAINING	2
6.0	INDUCTION.....	
7.0	TOOL BOX TALKS.....	2
8.0	INCIDENT/ACCIDENT AND NEAR-MISS REPORTING, INVESTIGATION AND FOLLOW UP .	3
1.0	HAZARD IDENTIFICATION AND RISK ASSESSMENT SYSTEM (HIRA)	3
2.0	SITE HSE COMMITTEE (CONTRACTOR).....	
3.0	MOTIVATION AND RECOGNITION.....	
4.0	SITE HSE INSPECTION/ AUDIT.....	4
5.0	FIRST AID FACILITY	4
6.0	FITNESS TO WORK.....	5
7.0	PERSONNEL PROTECTIVE EQUIPMENTS.....	6
8.0	EQUIPMENT LIST AND INSPECTION CERTIFICATE	7
9.0	HSE REQUIREMENTS AT SITE	8

ΣΣΣ

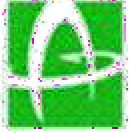

CITY GAS DISTRIBUTION PROJECT TENDER FOR PNG I&C CONNECTIONS

1.0 SCOPE

This specification establishes the Health, safety and Environment (HSE) aspects to be complied with by the contractor during construction at site.

1.1 Applicable Systems and Procedures

The reference standard for setting Quality, Health, Safety and Environment Systems and procedures will be as linked below –

- Guidelines issued by PNGRB.
- ISO 9001 - 2008 - For Quality System.
- ISO 14001 – 2004 - For Environmental Management System
- (OSHAS) 18001 - 2007 - For occupational health and safety management systems.

The Occupational Health & Safety Assurance Standard (OHSAS) 18001-2007 gives requirements for an occupational health and safety (OH&S) management system. It enables an organization to control its OH&S risks and improve its performance. It provides a basis for an organization to specify its OH&S performance criteria and design the management system.

OHSAS 18001 is compatible with the ISO 9001 (Quality) and ISO 14001 (Environmental) management systems standards. This facilitates integration of quality, environmental and occupational health and safety management systems by an organization.

Organization structure of the proposed CGD project includes a position for developing, installing and maintaining (with assistance by a specialist entity) Quality Assurance (QA) and Health, Safety and Environment (HSE) systems in line with ISO 9001-2008, OHSAS 18001-2007 and ISO 14001-2004 Standards.

Documented Standard Operating Procedures (SOP) will be prepared by the Owner/Owner's representative for CGD entity for QA and HSE, for application across the organization. Development of the SOPs and implementation of the same at construction sites, control rooms, regional and corporate offices will be followed by an internal audit to verify conformance.

The CGD Network operating entity will thereafter regularly monitor, through periodic internal and mandatory external audits, effective implementation of the SOPs at the construction sites, control rooms regional and corporate offices as per systems and procedures.

2.0 REFERENCES

This document should be read in conjunction with following.

- General Condition of Contract (GCC)
- Special Condition of Contract (SCC)
- Job Specifications
- Relevant IS codes, OSHAS standard
- Reporting Formats

3.0 RESPONSIBILITY & ORGANISATION

Health, Safety and Environment activities at site shall be under Contractor's scope. Contractor shall be responsible for implementation of HSE provisions. The nominated or designated safety engineer/ officer shall assist and perform day to day HSE work as per his advice.

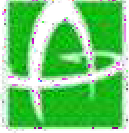

CITY GAS DISTRIBUTION PROJECT TENDER FOR PNG I&C CONNECTIONS

4.0 GENERAL REQUIREMENT

- 4.1. The contractor should follow HSE policy of owner as applicable to construction site.
- 4.2. The contractor shall ensure that HSE requirements are clearly understood & faithfully implemented at all level, at each site.
- 4.3. The contractor shall organize safety awareness programs regularly.
- 4.4. The contractor shall ensure his participation in every HSE meeting called by owner/owner representative.
- 4.5. The contractor shall conduct daily tool box talk.
- 4.6. Contractor shall ensure that their safety supervisor must be always present on the site.
- 4.7. Contractor shall take sufficient care in moving his plants, equipments and materials from one place to another place so that they do not cause any damage to any person or the property of the owner or any third party.
- 4.8. Working after sunset is strictly prohibited.
- 4.9. Hygiene requirement must be met on site by providing fresh drinking water at each site
- 4.10. The contractor shall submit Monthly HSE reports (Form attached in ANNEXURES).
- 4.11. The contractor shall provide one four wheeler at site during working hour to meet any contingency..
- 4.12. The contractor shall adhere consistently to all provisions of HSE .In case of non- compliance or continuous failure the owner/ owner representative may impose stoppage of work for the serious HSE violation. All works shall be carried out in presence of Owner/Owner's Representative only.

5.0 TRAINING

The Contractor duties shall include conducting HSE training for all activities and personnel involved. The Contractor shall ensure that their Personnel have been given the necessary HSE and work-related skills training in compliance with regulatory requirements prior to engaging the personnel for the work.

6.0 TOOL BOX TALKS

Contractor's Site Supervisor for specific work location shall conduct a tool box at the commencement of work on daily basis. If different team is working in different area, separate tool box talk covering location and hazard involved shall be carried out.

Each toolbox meeting shall cover the following agenda:

- 9 Discuss safety issues of previous day
- 9 Brief description of activities planned for the day & associated hazard
- 9 Information & resources required to put controls in place
- 9 Location specific hazard and instructions
- 9 Requirement of PPEs

It is the responsibility of supervisor to convey PPE requirement to all workers and ensure compliance of the same and shall be checked during tool box talk before embarking on work.

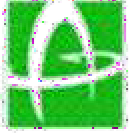

CITY GAS DISTRIBUTION PROJECT TENDER FOR PNG I&C CONNECTIONS

Tool box talk report shall be prepared and kept at site within one hour of talk and it must be signed by all attendee to ensure participation of all in the talk. Tool box report shall be submitted to CONSULTANT/OWNER

7.0 INCIDENT/ACCIDENT AND NEAR-MISS REPORTING, INVESTIGATION AND FOLLOW UP

7.1. Incident/Accident and Near-Miss Reporting

All incidents/accidents must be reported immediately. A report should be prepared by the Supervisor and submitted to the Site Manager within 12 hours of the occurrence and shall serve as a source for education of employee to prevent reoccurrence of similar incident/accident.

Contractor shall submit the Initial report of all Accidents/Incidents within 12 hrs to Owner / Consultant and detail report within 24 hrs. For serious incidents and near misses, with the potential for fatality, serious injury or significant environmental or material damage, Contractor shall notify Owner/Consultant without delay and within twenty four (24) hours.

7.2. Incident/Accident Investigation

All incidents/accidents must be reviewed and analyzed to establish root causes and type of injury, trends and practices.

Investigation shall begin promptly after the occurrence of the incidents/accidents. The completed incidents/accidents investigation report shall be submitted to the Contractor Site Manager within 7 days of the occurrence. A copy shall be submitted to Owner/Consultant.

7.3. Follow-up

All incidents/accidents, including investigation results and recommendations, shall be discussed in the Site HSE meeting and shall be brought to the notice of employees in toolbox meetings.

Key Risks Identification and Management *Risks*

Working at height is a critical activity. Following hazards are associated with Working at height:

- Person Fall from height
- Material falling From height
- Slips, trips and falls
- Concealed utilities (i.e. electric cable Telephone cable, water line, Drainage line)
- Electric shock

8.0 HAZARD IDENTIFICATION AND RISK ASSESSMENT SYSTEM (HIRA)

The Contractor shall prepare and implement comprehensive HIRA as part of the HSE Management Plan prior to Commencement of the work or services and during the execution of the work also.

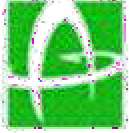

CITY GAS DISTRIBUTION PROJECT TENDER FOR PNG I&C CONNECTIONS

7.0 SITE HSE INSPECTION/ AUDIT

All Site HSE checklists/Inspection reports shall incorporate a follow-up procedure to ensure that any recorded HSE violations have been promptly attended to in a satisfactory manner.

The Site HSE Inspections/Audit shall be planned by the Contractor.

8.0 FIRST AID FACILITY

The contractor shall provide the first aid box at all the sites. The content of the first aid box shall include the following items:

- Twenty-four small sterilized dressings.
- Twelve medium size sterilized dressings.
- Twelve large size sterilized dressings.
- Twelve large size sterilized burn dressings.
- Twelve (15 gin) packets of sterilized cotton wool.
- One (200 ml) bottle of certified solution (1 per cent) or a suitable antiseptic solution.
- One (200 ml) bottle of mercurochrome (2 per cent) solution in water. (viii) One (200 ml) bottle of sal-volatile having the dose and mode of administration indicated on the label.
- One pair of scissors
- One roll of adhesive plaster (6 cm x 1 in).
- Two rolls of adhesive plaster (2 cm. x 1 in).
- Twelve pieces of sterilized eye pads in separate sealed packets.
- One polythene wash bottle (500 cc) for washing eyes.
- Twelve roller bandages 10 cm. wide.
- Twelve roller bandages 5 cm wide.
- Six triangular bandages.
- One tourniquet.
- A supply of suitable splints.
- Two packets of safety pins.
- Kidney tray.
- One copy of first-aid leaflet issued by the Directorate General of Factory Advice Service and Labour Institutes, Government of India, Bombay.

All the content shall be kept in clearly marked and easy to remove cartons stored in such a manner that there is no rattling or spilling over even when the container is being moved Whenever applicable the cartons shall bear instructions for use, dosage etc.

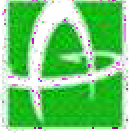

CITY GAS DISTRIBUTION PROJECT TENDER FOR PNG I&C CONNECTIONS

9.0 FITNESS TO WORK

The objective of Medical Assessment for Fitness to Work (FTW) is to assess health of employees in relation to their specific jobs such as working at height, to ensure they could perform required task without risk to health and safety.

The Contractors workers (as per the above category) shall under go through FTW prior to start work at site. It will be the responsibility of the Contractor to ensure compliance to this requirement.

9.1. Medical Examination requirement for working at height

Below specific requirements are must for Medical examination of Contractors employees working at height:

- 2) History of Epilepsy.
- 3) Blood Pressure.
- 4) ECG+ any History of any Seizures.
- 5) Vision Check.
- 6) Blood Sugar (fasting & PP).
- 7) And other general tests.
- 8) Physical Examination- to confirm the person is physically fit.
- 9) Blood Group (One time Test).
- 10) General check about fear of Heights.

9.2. Other Requirements:

- Contractor to ensure that persons involved in working at height are trained, certified and having Valid I Card.
 - Carry out tool box talk before starting of the work.
 - Carry out site specific risk assessment and identify risk control measures for specific site work. (Ref doc).
 - Ensure that persons are physically & mentally fit for working at height.
 - Ensure that equipment shall be used as per approved standard for working at height.
 - Ensure that equipment shall have facility of emergency rescue operation.
 - Ensure person involved in working at height are trained in emergency rescue operation.
 - Ensure that all equipment and safety devices used are inspected, certified by competent authority & valid & suitable for use.
 - Quality conformance shall be carried out prior to start of work for working at height equipments.
 - Life cycle of equipment shall be checked
 - In case of any part of equipment is found damaged or defective, it will be destroyed. "Working at height equipments shall never being repaired". The Records, showing reasons for all the defective and damaged material shall be available and shall be stored separately at Contractor's yards.
 - Ensure that Personnel Protective Equipment are inspected & in good condition
 - Ensure that equipment used is within Safe working load mentioned on equipment.
 - Ensure all tools are secured or kept in Tool kit / bag and there are no loose objects or tools.

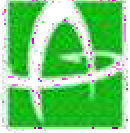

**CITY GAS DISTRIBUTION PROJECT
TENDER FOR PNG I&C CONNECTIONS**

10.0 PERSONNEL PROTECTIVE EQUIPMENTS

The contractors shall provide sufficient numbers of following personnel protective equipments (PPEs) to workmen and supervisors/engineers to use them properly at work site.

Following five numbers of Personnel protective equipments are identified as MANDATORY for all.

11. Safety Helmet
12. Coverall
13. Safety shoes/footwear
14. Safety Glasses
15. Hand Gloves (as per job requirement)

Other PPEs shall be as per job requirement like

Work at height- Full body harness (Petzl or equivalent make), Life line, Safety

Net Arc Welding – Welding face shield

Grinding – Grinding face shield

Height work – Full Body harness (above 2 meters)

Contractor to ensure proper use and selection of protective clothing / equipment for specialized jobs

PPE's to be used shall be as per following Specification:

IS : 2925 – 1984	:	Industrial Safety Helmets.
IS : 4770 – 1968	:	Rubber gloves for electrical purposes
IS : 6994 – 1973 (Part – I)	:	Industrial Safety Gloves (Leather & Cotton)
IS : 1989 – 1986 (Part – I & III)	:	Leather safety boots and shoes
IS : 3738 – 1975	:	Rubber knee boots
IS : 5557 – 1969	:	Industrial and Safety rubber knee boots
IS : 6519 – 1971	:	Code of practice for selection, care and repair of Safety footwear
IS : 11226 – 1985	:	Leather Safety footwear having direct moulding sole
IS : 5983 – 1978	:	Eye protectors
IS : 9167 – 1979	:	Ear protectors.
IS : 3521 – 1983	:	Industrial Safety belts and harness

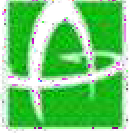

**CITY GAS DISTRIBUTION PROJECT
TENDER FOR PNG I&C CONNECTIONS**

Technical Standard for working at height equipments shall be as per following standard:

Quality Standards

Sr. No.	Name of equipments	EN Standard
1	Energy absorbers	365
2	Slings	566
3	Retractable type fall arresters	360
4	Guide Type fall arresters on a rigid anchorage	353-1
5	Connectors	362
6	Dynamic mountaineering rope	892
7	Descender device	341
8	Anchor device Type-A/B	795
9	Fall arrester harness	361
10	Sit harness	813
11	Lanyards	354
12	Pulleys	12278
13	Fall arrester system	363
14	Work positioning belt	358

11.0 EQUIPMENT LIST AND INSPECTION CERTIFICATE

Equipment list must be made available and must be certified for safety as per the requirement of Factory Act. Tools and Tackles should be calibrated from the approved agency only.

List of Tools and Tackles

Item	Inspection/Calibration Date
Full body harness	Once in six Month
Rope Grab fall arrestor	Once in six Month
First Aid Box	Once in Month
Fire Extinguisher (10 Kg.)	Once in a Year
Extension board(without cable Joint with Socket) with Circuit Breaker	Monthly
Nylon tie line for tools	Once in a day



CITY GAS DISTRIBUTION PROJECT TENDER FOR PNG I&C CONNECTIONS

12.0 HSE REQUIREMENTS AT SITE

- 12.1. Contractor may conduct survey to assess the requirement of GI riser for high rise building.
- 12.2. For Work at Height: Contractor shall provide PETZL or equivalent system/metallic scaffolding as a working platform and full body harness with self locking arrangement. Full body harness with self locking arrangement shall be used for ascending/descending/work rest.
- 12.3. PETZL system or equivalent system/ metallic scaffold should comply with relevant IS/EN/BS standard.
- 12.4. Only certified trained plumber undergone practical training on work at height shall be deployed.
- 12.5. Any working at height related activities has to be carried out with Permit system.

12.6. Work at Height

Working at Height is performing work at height where workers can fall 1.8m or more from where they stand or sit to perform work. This includes gaining access to working at height if there is a risk of falling 1.8m or more.

Examples of Working at Height are:

- 6) Working on temporary platform more than 1.8m high
- 7) Working on top of vehicles/tankers or building more than 1.8 m high

Risk of Working at Height

- 8) Fall from height
- 9) Falling objects

Safety net, fall arrest system and two lanyard full body harness when working at height

While working at height, all loose tools shall be kept inside a container and good housekeeping shall be maintained.

All Working at Height shall comply with Working at Height Procedures

12.6.1. Safety Net System

"Safety net systems" Safety net systems and their use shall comply with the following provisions:

- 7) Safety nets shall be installed as close as practicable under the walking/working surface on which workers are working, but in no case more than 30 feet (9.1 m) below such level. When nets are used on bridges or similar kind, the potential fall area from the walking/working surface to the net shall be unobstructed.

Vertical distance from working level to horizontal plan of net	Minimum required horizontal distance of outer edge of net from the edge of the working surface
Up to 5 feet	8 feet
More than 5 feet up to 10 feet	10 feet.
More than 10 feet	13 feet

- Safety nets shall be installed with sufficient clearance under them to prevent contact with the surface or structures below when subjected to an impact force.
- Safety nets and safety net installations shall be drop-tested at the jobsite after initial installation and before being used as a fall protection system, whenever relocated, after major repair, and at 6-month intervals if left in one place. If drop test not possible designated competent person shall certify that the net and net installation is in compliance with the requirement by preparing a certification record prior

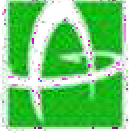

**CITY GAS DISTRIBUTION PROJECT
TENDER FOR PNG I&C CONNECTIONS**

to the net being used as a fall protection system. The certification record must include an identification of the net and net installation for which the certification record is being prepared; the date that it was

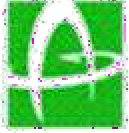

CITY GAS DISTRIBUTION PROJECT TENDER FOR PNG I&C CONNECTIONS

determined that the identified net and net installation were complying and the signature of the person making the determination and certification. The most recent certification record for each net and net installation shall be available at the jobsite for inspection.

- 5) Defective nets shall not be used. Safety nets shall be inspected at least once a week for wear, damage, and other deterioration. Defective components shall be removed from service. Safety nets shall also be inspected after any occurrence which could affect the integrity of the safety net system.
- 6) Materials, scrap pieces, equipment, and tools which have fallen into the safety net shall be removed as soon as possible from the net and at least before the next work shift.
- 7) The maximum size of each safety net mesh opening shall not exceed 36 square inches (230 cm) nor be longer than 6 inches (15 cm) on any side, and the opening, measured center-to-center of mesh ropes or webbing, shall not be longer than 6 inches (15 cm). All mesh crossings shall be secured to prevent enlargement of the mesh opening.
- 8) Each safety net (or section of it) shall have a border rope for webbing with a minimum breaking strength of 5,000 pounds (22.2 kN).
- 9) Connections between safety net panels shall be as strong as integral net components and shall be spaced not more than 6 inches (15 cm) apart.

12.6.2. Life Line

- Horizontal or vertical life line shall be used while working on suspended platform or similar type of platform or working at the roof/edge
- Horizontal/Vertical lifelines shall be designed, installed, and used, under the supervision of a qualified person, as part of a complete personal fall arrest system, which maintains a safety factor of at least two.
- Lanyards and vertical lifelines shall have a minimum breaking strength of 5,000 pounds (22.2 kN).
- When vertical lifelines are used, each worker shall be attached to a separate lifeline.

12.6.3. Full Body Harness

- Ensure that the full body harness must be inspected prior to use.
- Ensure that full body harness must be worn by the workmen while working at height.
- Full body harness lanyard must be anchored with a strong member.
- While climbing up or climbing down, one of the hooks of lanyard must be locked alternatively all the time.

12.6.4. Working Platform

Every Working platform more than 1.8 mtr. High from which a person is likely to fall shall be of steel plates/planks/cage and shall be:

- a. Closely boarded, planked or plated.
- b. At least 700 mm wide if the platform is used as a footing only and not for the deposit/ keeping of materials.
- c. At least 900 mm wide if the platform is used for the deposit of materials.
- d. At least 1100 mm wide if the platform is used for the support of higher platform.

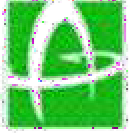

**CITY GAS DISTRIBUTION PROJECT
TENDER FOR PNG I&C CONNECTIONS**

- e. Two metal/planks shall not have 25 mm gap between them the distance between two consecutive transoms or other supports on which a platform rests shall be fixed with due regards to the anticipated load and the nature of platform flooring. As a general rule such transoms shall not be placed more than 1.0 mtr apart.

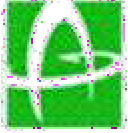

**CITY GAS DISTRIBUTION PROJECT
TENDER FOR PNG I&C CONNECTIONS**

12.6.5. Scaffold

12.6.5.1. Scaffold Inspector (Project Field Officer)

This is the competent individual who shall inspect scaffolding prior to each use and perform full inspections as per the Inspection procedure. He will accept the Scaffold after ensuring the followings;

- a) The scaffold erected complies with legislation.
- b) The permissible loads per deck and the working distance between the scaffold and the work surface are examined.
- c) Materials used for the scaffold are in a proper condition and in throughout the time it is in place.
- d) Existence and proper installation of collective protective equipment and means of access.
- e) Clear display of details of permissible loads on the scaffold.
- f) Acceptance is carried out prior to the scaffold being made available for the first time and is repeated after any alterations.
- g) Inspection is repeated at the frequency of 7 days. Issue scaffold tag (Green Tag) before its first use.



CITY GAS DISTRIBUTION PROJECT
TENDER FOR PNG I&C CONNECTIONS

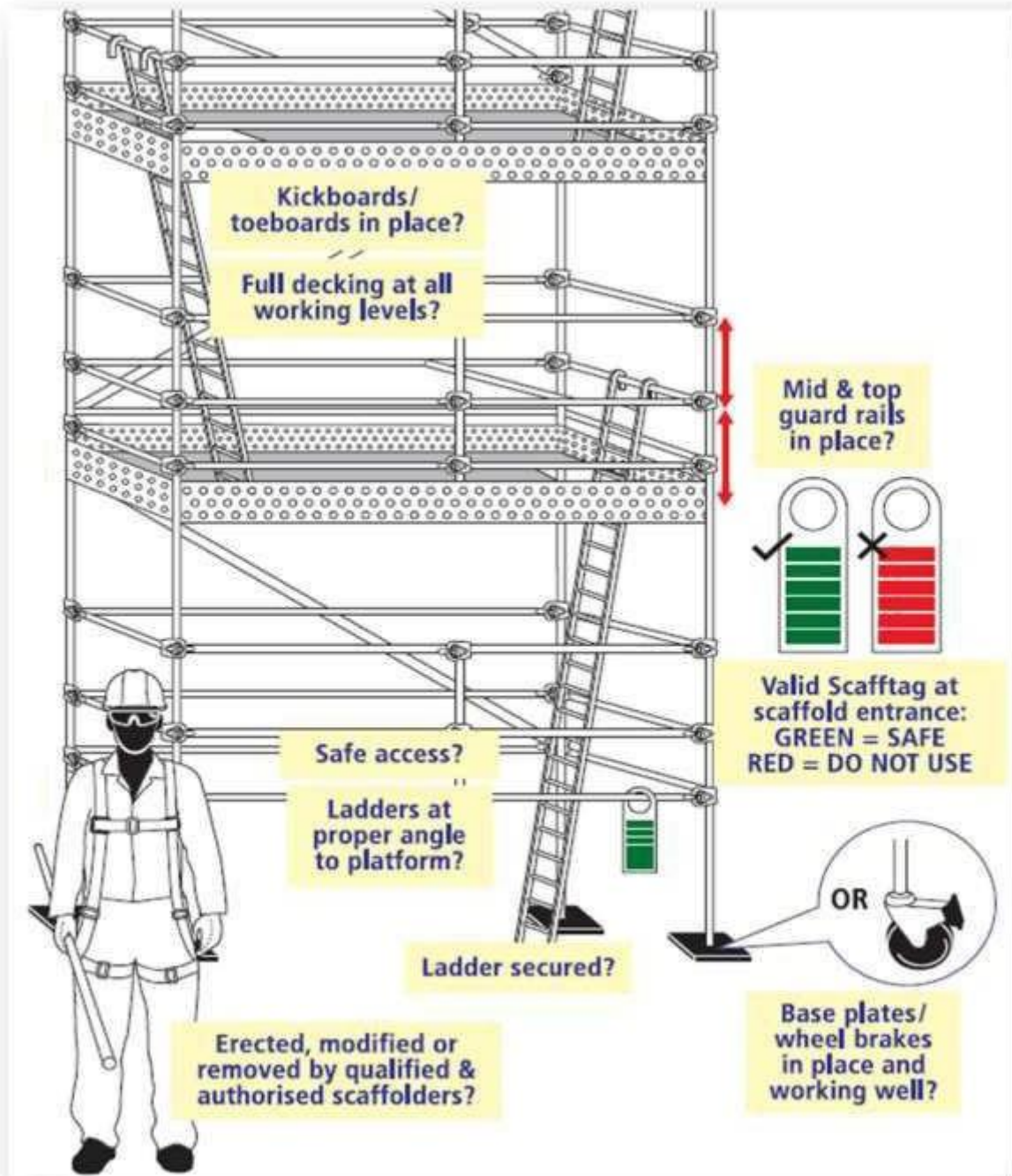

12.6.5.2. Scaffold Contractor

- f. This refers to the company involved in the installation (erection, dismantling and alteration) and/or design of the scaffolding on behalf of CONTRACTOR.
- g. The erection contractor shall ensure that the scaffolding is erected in compliance with the OHSAS/IS standards. Worksite specifications and considerations shall be incorporated into any such plan.
- h. Ensure availability of competent staff and certified material all the time.

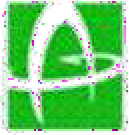

CITY GAS DISTRIBUTION PROJECT TENDER FOR PNG I&C CONNECTIONS

- / Scaffolding may be erected, dismantled or altered only under the supervision of a competent individual who has received adequate specific training for the intended operations, specifically including the following:
- / Understanding the erection, dismantling and alteration plans for the scaffolding
- / Ensure PPEs and Safety at work during erection, dismantling and alteration of the scaffolding.
- / Measures designed to prevent the risk of falling persons and objects.
- / Safety measures applicable in the event of a change in weather conditions.
- / Permissible structural load criteria.
- / Any other risk that may be entailed by erection, dismantling and alteration operations.
- / Scaffold material: Safe handling, and storage.

12.6.5.3. Scaffold User

- iii. The User shall ensure that acceptance of the scaffold has been properly carried out; green Tag is issued and provide notification of any alterations. Work from tagged scaffolds only. Comply with special conditions/additional controls noted on the access tag.
- iv. It shall observe all restrictions on use (particularly permissible loads). Its requirements should be taken into consideration in the specifications during erection.
- v. Use scaffolds only for their intended purpose.
- vi. Do not use unstable objects or makeshift devices to increase the working height of the scaffolds.
- vii. Use portable ladders as a means of increasing the working height only after the competent person has determined that the stability of the structure has not been compromised, and adequate fall protection is in place.
- viii. Do not straddles, stand on, or work outside of the guardrail.
- ix. Use designed access means to descend or ascend a scaffold (stairs, attached ladder, or specially designed end frames). Do not use cross bracing or side rail
- x. Keep only the tools and materials on the platform that are necessary to perform the task. Control all slipping and tripping hazards by removing or securing the tools/materials.
- xi. Do not modify or remove a scaffold system/component or status tag.
- xii. Notify supervision immediately if a scaffold is damaged, weakened, or otherwise deficient.
- xiii. Scaffold users/ Scaffold erectors shall use IS and EN standard double lanyard safety harness with absorbent.

12.6.5.4. Inspection Points

To ensure the integrity and proper installation of scaffolding, a certain number of points shall be inspected. Inspection of these points ensures a basic level of safety. Following fundamental inspection points are as follows:

- e. Environment and location
- f. Supports and soleplates
- g. Structure and posts
- h. Decks
- i. Scaffold Capacity Standards
- j. Working levels

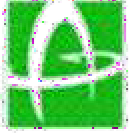

CITY GAS DISTRIBUTION PROJECT TENDER FOR PNG I&C CONNECTIONS

- e. Access
- f. Signs and signage

12.6.5.5. Mobile Scaffolding

- g. Mobile scaffolds are identical in design to fixed scaffolds, except that their tubular structure is lighter and in terms of support, the wheels do not offer the same load-bearing area as footplates on fixed scaffolds.
- h. Erection is simple and shall be carried out using personal protective equipment. Lastly, during erection, dismantling and use, the brakes shall also be applied. Care should be taken to ensure that mobile scaffolds are installed on flat surfaces.
- i. Mobile scaffolds are highly practical for short jobs at relatively low heights.
- j. Acceptance is carried out after erection has been completed.
- k. They are moved as the work being carried out progresses. No fresh acceptance is required after each move, but the workstation shall be verified (working distance, brakes applied)
- l. A freestanding scaffold shall be considered safe when the total height is equal to or less than four times the minimum or least base dimension.
- m. Rules for use
 - n. Do not extend the base to increase the height.
 - o. Brace each frame level as per the manufacturer's instructions.
 - p. Do not raise work surfaces by placing decks on rails or mid rails.
 - q. Do not climb on the guardrails or other structural components.
 - r. Observe the manufacturer's guidelines governing the installation of brackets, material hoists, etc.
 - s. Stay clear of power lines and observe safety distances. (If any)

12.6.5.6. Scaffold Safety

The following safety tips are as guidelines in avoiding job-site situations that could prove dangerous to scaffold workmen.

- b. **The Scaffold to the Building:** Scaffolding should be tied to the structure using heavy wire or tie-in devices. The first vertical tie should be at the maximum height of 4 times the narrowest base dimension. Additional ties are not to exceed 26 feet vertically. Maximum horizontal distance between ties is not to exceed 30 feet.
- c. **Don't Overload Scaffolding:** Follow the safe load capacities as given by the scaffold manufacturer. There's a limit even to what steel can support. A 4-to-1-safety factor must be figured on scaffolding.
- d. **Use Metal Catwalks, Platforms;** where available. If wood plank is used, it must be scaffold grade or better. Inspect thoroughly before every job to make sure it is free from breaks, knots, and cracks or warp age. Decking should be full width.
- e. All working platform must be constructed with the specific requirement of job.
- f. If the working platform is not permanent then safety belt must be used.
- g. There shall be firm foundation for all scaffoldings. All scaffolding shall be made of sound material.
- h. Scaffolding material shall be inspected and used, only if found in good condition.
- i. Provide metal base plate is used under all upright or standard scaffoldings. Correct type of couplers shall be used for all connections.

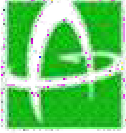

**CITY GAS DISTRIBUTION PROJECT
TENDER FOR PNG I&C CONNECTIONS**

- e. Plumb and level scaffoldings as erection proceeds, so that braces will fit without forcing. Fasten all braces securely.
- f. Working platforms shall be provided with guards. This should consist of top rail, mid rail, and toe board. The toe board shall be of minimum height 100 mm, while the mid rail and top rail shall be at heights of 600 mm and 1200 mm respectively.
- b. Do not use ladders or makeshift devices on top of scaffoldings to increase the height.
- c. Shall be placed at least 75 deg. to the floor.
- d. Fall arrestor to be used where ever applicable.

The following safety tips are as guidelines in avoiding job-site situations that could prove dangerous to scaffold workmen.

- vi. Don't Ride Moving Scaffold; and remember scaffold units are limited in height to 4* times their narrowest base dimension (unless base is widened by outriggers, or more end frames; or tied into building.) Always keep casters locked. (except to re-spot)
- vii. Don't Climb Braces: Use the steps provided on most steel scaffoldings to climb up to or down from work levels. Use scaffold climbing ladders where required.
- viii. Protect Working Levels: Use overhead canopies to protect workers on lower work levels when work is being done overhead. Rope off unsafe areas underneath scaffold or provide wire mesh around work area.
- ix. Use Double Guard Rails; and toe boards on exposed sides at platform heights of 1.8 meter or more.



CITY GAS DISTRIBUTION PROJECT TENDER FOR PNG I&C CONNECTIONS

12.6.5.7. Illustration of a Sample Independent Scaffold

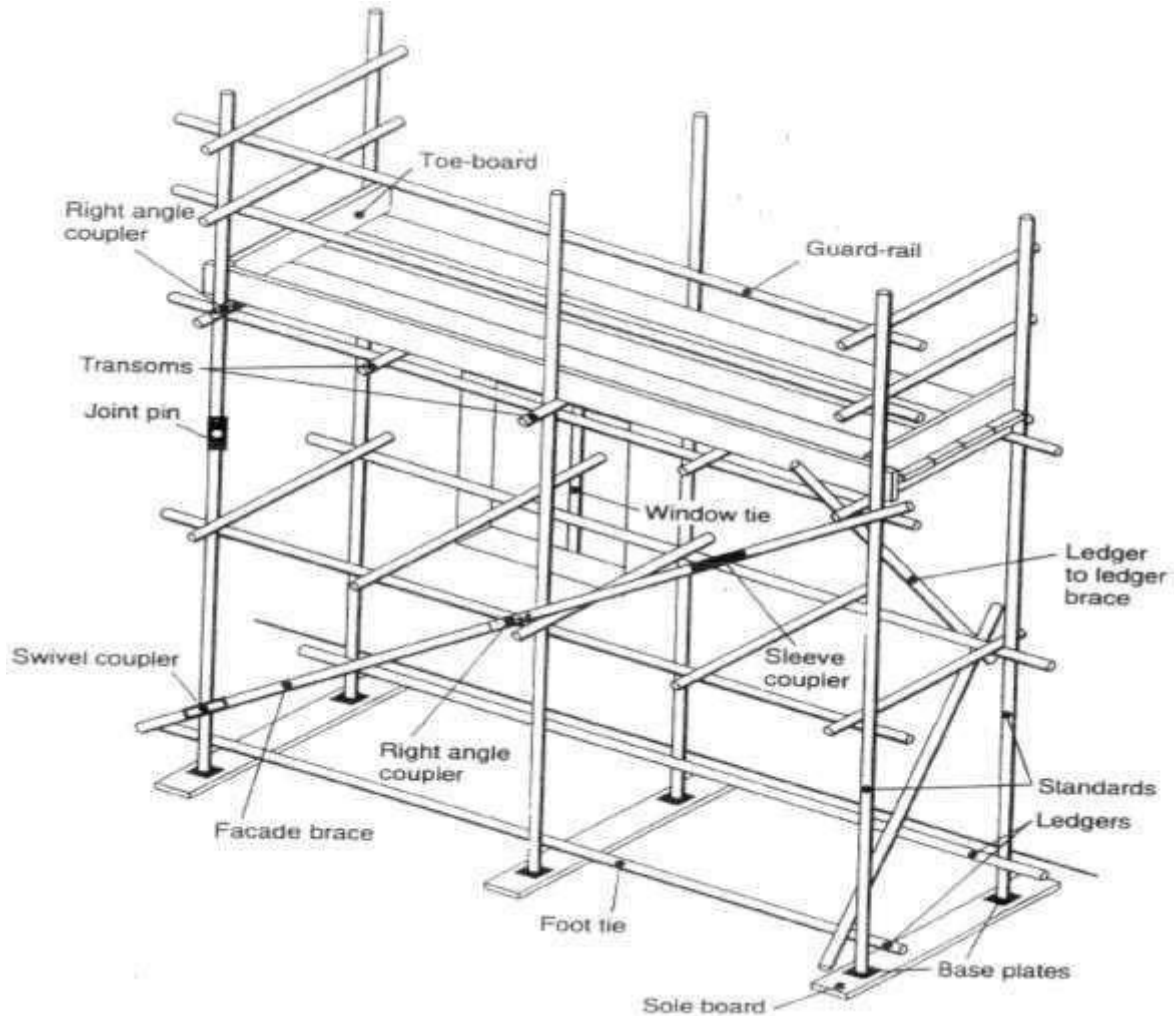

12.6.6. Ladders

- c) Fall protection is not needed when climbing up or down ladders less than 20 feet/6.1 meters, using 3 points of contacts.
- d) Portable ladders, steps and trestles should only be used for light duties of short duration. Otherwise, properly constructed means of access should be provided.
- e) Aluminum ladders can generate sparks when struck against rusty iron, so it must be used in Hazardous Areas with special care.
- f) Aluminum ladders must not be used in areas where they might be splashed with acids or alkalis; e.g. Utilities Area.

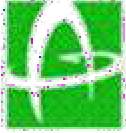

**CITY GAS DISTRIBUTION PROJECT
TENDER FOR PNG I&C CONNECTIONS**

- a. Ladders with metal reinforced, Damaged or rotten stiles, missed footing on ladder rungs must not be used.
- b. Over-reaching and over-balancing are not allowed.
- c. Every time before use, the user will carry out inspection of ladder.
- d. If the work to be done necessitates the use of both hands, a safety belt must be used.
- e. Tools and materials must not be hand carried by persons ascending or descending ladders. Where applicable light tools should be carried in pockets, tool belts or shoulder bags, provided they do not impair movement and are held securely.
- f. Rungs, stiles, or treads to be checked for bending, twisting or signs of abuse or undue wear.
- g. Feet to be fitted with various types of bases and in good order. Synthetic non-slip, wooden or metal.
- h. Non-slip stair treads mats of stepladders, should be fitted and in good condition.
- i. In case of moving ladders fitted with wheels, Hinges and locking devices to be secure and in good working order.
- j. All portable ladders must be in good condition as per the site norms.
- k. Ladder shall extend 3' to 4' above the point of Landing and topmost 3 rungs shall not be used.
- l. Ladder is checked visually for defects before every use.
- m. Ladders shall not be used in a horizontal position as runways or scaffoldings.
- n. Ladders shall not be placed in front of a door that opens toward the ladder unless the door is locked, blocked or guarded.

12.6.7. User Ladder Safety Check List

The following check list specifies the main points to remember when using ladders:

- JJ. Do not erect:
- KK. On sloping ground
- LL. On top of movable objects
- MM. In high a wind
- NN. In front of a door which may be opened
- OO. Against a slippery or unstable surface
- PP. At a shallow angle, or use horizontally as a plank or bridge
- QQ. Leaning to one side

12.6.8. Do not

- JJJ. Drop things from a ladder
- KKK. Straddle from the ladder to a nearby foothold
- LLL. Allow more than one person up a ladder at a time
- MMM. Use a ladder which is too short
- NNN. Use a makeshift or 'home-made' ladder
- OOO. Over-reach (generally always keep hips within the stiles)
- PPP. Overload a ladder or support it with a plank bearing on a rung

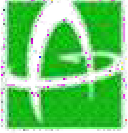

**CITY GAS DISTRIBUTION PROJECT
TENDER FOR PNG I&C CONNECTIONS**

- W. Slide down a ladder
- X. No ladder should be used if it has: A missing, loose or defective rung or tread
- Y. A defective stile side member
- Z. A defective rope or associated fitting (rope operated extension ladders)

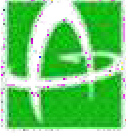

CITY GAS DISTRIBUTION PROJECT TENDER FOR PNG I&C CONNECTIONS

- iv. Any sign of warping
- v. Missing fastenings or rivets, guide or latching hooks
- vi. Always Return ladders to store as soon as they are finished with
- vii. Inspect a ladder immediately after any fall or overload

12.6.9. Activities Allowed on Ladder

- v. A ladder is considered to be suitable for access of personnel to an elevated area only. No significant works may be carried out from a ladder. In particular, activities such as those below may not be carried out on a ladder:
- vi. Carrying tools (other than those which might clip onto a tool belt) up to an elevated level.
- vii. Activities involving heavy manual labor.
- viii. Activities requiring reaching or stretching such that the body is no longer centered over the ladder.
- ix. For these types of jobs, a work platform such as a scaffold is required. The safe working position from a ladder is to have both thighs and hips within the styles.

12.6.10. Colour code and inspection

- v. Colour code of the year shall be painted on one style only and equal to one rung spacing.

12.7. **Roof work**

- iv. All roof-work operations should be pre-planned and properly supervised.
- v. Roof work should only be undertaken by workers who are physically and psychologically fit and have the necessary knowledge and experience for such work.
- vi. Work on roofs shouldn't be carried on in weather conditions that threaten the safety of workers.
- vii. Crawling boards, walkways and roof ladders should be securely fastened to a firm structure.
- viii. Roofing brackets should fit the slope of the roof and be securely supported. Where it is necessary for a person to kneel or crouch near the edge of the roof, necessary precautions should be taken.
- ix. On a large roof where work have to be carried out at or near the edge, a simple barrier consisting of crossed scaffold tubes supporting a tubing guardrail may be provided.
- x. All covers for openings in roofs should be of substantial construction and be secured in position.
- xi. Roofs with a pitch of more than 10 should be treated as sloping.
- xii. When work is being carried out on sloping roofs, sufficient and suitable crawling boards or roof ladders should be provided and firmly secured in position.
- xiii. During extensive work on the roof, strong barriers or guardrails and toe-boards should be provided to stop a person from falling off the roof.
- xiv. Where workers are required to work on or near roofs or other places covered with fragile material, through which they are liable to fall, they should be provided with suitable roof ladders or crawling boards strong enough and
- xv. When spanning across the supports for the roof covering to support those workers.
- vii. A minimum of two boards should be provided so that it is not necessary for a person to stand on a fragile roof to move a board or a ladder, or for any other reason.

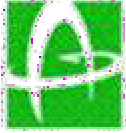

CITY GAS DISTRIBUTION PROJECT TENDER FOR PNG I&C CONNECTIONS

12.8. **Electrical Safety**

- f) Only authorized electrical engineer / electricians are permitted to do the electrical work.
- g) Do not use extension cords or electric hand tools with exposed wires.
- h) To switch-off electrical supply in case of an emergency must be enabled at all times.
- i) All temporary electrical installations carried out on the site must be in accordance with the local regulations and specifications.
- j) The installations must be inspected regularly by a competent person (e.g. electrical engineer/supervisor) to ensure that they are in safe condition and working faultlessly.
- k) Each electrical power tools and electrical equipment must be under protection of earth leakage/residual current protective device (ELCB/RCCB).
- l) Portable power tools used on site must have protective insulation ("double insulation").
- m) All electrical machines, tools and appliances must be inspected by a competent person (e.g. electrician) to ensure that all equipment's are in safe condition and working faultlessly. To confirm that the inspection was conducted the equipment must be labelled or marked clearly and registered. The documentation must be submitted to TE for records.
- n) Assume that all circuits are live until they have been thoroughly checked and proven dead. Never work on a live circuit.
- o) When using electrical equipment in an environment with electrical conductivity (e.g. in confined spaces like case pipes, containers, towers) the voltage used may at maximum be 24 Volt AC. (fed from a safety low voltage transformer)
- p) Never use a fuse heavier than the capacity of the circuit. Also, never attempt to bridge a fuse.
- q) Never tamper with any electrical wiring or apparatus.
- r) Do the cable laying as per standard specifications and requirement; do not lay down power cables adjacent to secondary cables of welding machine.
- s) Assess overhead power line hazard and keep safe distance from it.
- t) All electrical equipment's, motors, transformers, welding machines, etc. to be provided with earth connections.

12.9. **Power & Hand Tool Operation**

- iv. All portable tools are to be connected through control bus with ELCB.
- v. All contractors should ensure proper Earthing of all electrical equipment's used by them. Suitable earthing pits must be made if required.
- vi. Examine electric cable for defects before use.
- vii. Do not ever insert free ends of wires into sockets and hold them in place with matchsticks / other means. Always use industrial three pin plugs.
- viii. Check the RPM rating of grinding wheels. The RPM rating must be greater than or same to that of the driver. Wheel guard should be used in proper position before grinding. Also proper PPEs must be ensured (goggles & hand gloves).
- ix. Do not tie electric cords to metal rods or nails.
- x. No cable should run under the ground. It must run overhead at a 2 m height to avoid pinch point and creating trip hazard
- xi. All tools and Tackles must be examined daily before commencing work and record to be maintained.
- xii. Defective tools are to return to store.

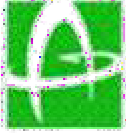

CITY GAS DISTRIBUTION PROJECT TENDER FOR PNG I&C CONNECTIONS

- vii. All electrical tools must be inspected at regular intervals by an authorized electrical person and record to be maintained.
- viii. The weight, size & type of tool should be selected to suit the job carried out.
- ix. The handles of tools should be intact and properly tightened. Split handles should be replaced. To avoid slippage, grease and oil should be wiped off.
- x. Insulated and non-conducting tools shall be tested for electrical resistance.
- xi. Wrenches should not be pushed but pulled. Chisels struck by others should be held by tongs and not by hands.
- xii. Chipping should always be done away from self.
- xiii. Hand tools should not be allowed to lie down on benches, scaffoldings etc. from where they can fall. They should be properly stored.

12.10. **Welding**

The metal frames and cases of mains-powered welding rectifiers, transformers and voltage regulators and of engine driven welding machines must be positively earthed locally throughout the work.

- f) Welding leads and return leads must be protected against physical damage.
- g) Insulated electrode holders and cable lugs / protectors must be used.
- h) The return lead must be attached to the work place as close as reasonably practicable to the welding point.
- i) If mains power is used, the work piece must be positively earthed using a well-protected earth wire connected at both ends by bolted lugs or secure screw clamps.
- j) Bolted joints in pipelines and structures must not be relied upon to provide adequate electrical continuity for welding currents.
- k) Electric arc welding should not be carried out on equipment suspended from a crane because of the risk of damage to lifting wires from uncontrolled stray currents.
- l) Welders must not wear metal rings, bracelets or necklaces during the work as induced currents from the welding equipment might heat these.
- m) Dry, non-conductive gloves should be worn.
- n) The welder must always disconnect the electrode holder from the supply before attempting to replace an electrode.
- o) The welder should not lean against an earthed conductor whilst manipulating live electrodes.
- p) Welders working with electrodes fed from different phases of a three-phase supply should not work in close proximity to one another.
- q) Ensure that welding machine is in order and approved by site engineer.
- r) Ensure that welding cables are in order.
- s) Remove all combustible material from welding area to avoid fire.
- t) Place a fire extinguisher nearby welding premises.
- u) Ensure welding holder, cable and its lugs in good condition and use only industrial power socket and plugs (3 Pin) to avoid electricity risk.
- v) Make sure that welding machine is provided with ON/OFF switch and is earthed/ grounding.
- w) Do not over load electrical appliances and cable, shocked pin etc.

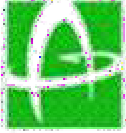

**CITY GAS DISTRIBUTION PROJECT
TENDER FOR PNG D I&C CONNECTIONS**

12.11. Gas Cutting

- d) Gas cylinders must be secured in the vertical position to prevent them being knocked or pulled over.
- e) Long lengths of hose should be avoided, but; -
 - Cylinders must be kept far enough away from the welding or cutting operations to prevent contact with sparks, flames and metal splatter.
 - Cylinders must be placed where they are unlikely to be damaged by stray electric currents or falling objects.
- iii. Cylinders must not be taken into confined spaces.
- iv. The torch must always be lit from a lighter provided for the purpose. There should be no attempt to light it from hot metal.
- v. Check the cylinder and its valve or leakage and move out any leaking cylinder immediately.
- vi. Ensure that flash back arresters are installed with torch and NRV (Non return valve) on the gas cylinders side.
- vii. Ensure cylinder is far away from fall of sparks and hot metal.
- viii. Check the regulator and torches that they are inspected prior to every use.
- ix. Check for leaks around regulators, hoses/fittings & nozzle with soap solution.
- x. Check the entire hose length if it is cracked or worn out cut that length of hose or replace the hose.
- xi. Check that flash back arrester used for the purpose is of approved make/specification only.
- xii. Place a fire extinguisher nearby welding premises.

12.11.1. Gas Cylinders

The handling of gas cylinders must comply with local legislation and TE's regulations as per particulars given below:

- vi. Gas cylinders must be stored protected from excessive heat, fire, dangerous corrosion, mechanical damage or access by unauthorized.
- vii. Gas cylinders must not be stored together with flammable materials.
- viii. Gas cylinders must be secured to prevent them from falling over.
- ix. Gas cylinders must be capped and operated upright.
- x. Use cylinder trolley / cage for the transportation of gas cylinders at site.
- xi. Never use oil or grease on the regulator of a cylinder valve.
- xii. Store gas cylinders in ventilated area.
- xiii. Don't keep LPG cylinder in confine/below ground area.
- xiv. Gas stores must not be set up in critical areas such as stairways, corridors, emergency routes, garages or passages for persons or vehicles.
- xv. Never transport by rolling them on the ground or use them as rollers or supports.
- xvi. Never attempt to repair a cylinder.
- xvii. Leaking regulators, cylinder valves, hose pipes or other equipment should be taken out of service.

12.12. Grinding Operation

- Grinding wheels should be stored in dry place.



CITY GAS DISTRIBUTION PROJECT TENDER FOR PNG I&C CONNECTIONS

- f* After expiry date, grinding wheel must be condemned, broken in to pieces.
- f* Power supply cable of adequate current carrying capacity shall be used and it should be in good workable condition without abrasions, cuts or puncture in outer insulation.
- f* Socket pin provided at supply end and On/off switch in working condition.
- f* Proper earthing of the body in case of metallic body.
- f* Wheel guard properly fitted in position.
- f* Machine body without any damage like crack etc.
- f* Moving part (wheel) must be properly fixed to the machine with the help of spanner.
- f* Grinding wheel must be of suitable size as per the speed of grinding machine.
- f* Grinding wheel without manufacturer's sticker showing size, speed and expiry date must be condemned.
- f* Don't use portable grinding machine as bench grinder.
- f* Don't fit over size wheel than recommended size by machine/wheel manufacturer.
- f* Don't grind small, unstable object without fixing it in the vice.
- f* Don't over press the grinding wheel against the job for fast removal of metal.
- f* Put OFF the main switch, while machine is not in use (tea break etc.).
- f* Don't chip off grinding/cutting wheel for achieving fast cutting rate.

PPEs:

- Use of helmet, face shield or safety goggles (where face shield is not possible.) and hand gloves.

12.13. Use of Power Tools and Cables

- All electrical equipment and tools used by the contractors and their employees shall be properly checked by contractor's supervisor before use.
- All power tools must have proper guard at all time.
- Leads /cables must be placed so that they do not create a tripping hazard.

12.14. Pressure / Leak Testing

Hydrostatic and Pneumatic Test

Access to the test area shall be limited to essential personnel only. before the test commences compliance is required with the following points:

- Persons supervising pressure or leak tests must have sufficient knowledge and experience of testing to fully understand the hazards of the activity and the precaution, which must be taken.
- Effective communication, including formal procedures, must be established between sites whenever the test envelope extends beyond one site, for example, pipelines.
- The area shall be cordoned off (using tape, shields or barriers, etc) at an adequate distance from the equipment to be tested, as specified on the Permit to Work
- Warning signs shall be posted at access ways, at other strategic positions, and on the equipment to be tested (including the doors of test workshops or other designated areas
- Pressuring equipment shall be provided with suitably calibrated pressure control / regulator devices.



CITY GAS DISTRIBUTION PROJECT TENDER FOR PNG I&C CONNECTIONS

- Pressuring equipment shall not be left unattended at any time during the test.
- Pressuring equipment shall be isolated from the equipment under test and where practicable disconnected, when the test pressure has been reached.
- Care must be taken to ensure that materials of construction have the required ductility at the test temperature to prevent brittle fracture.
- A safety valve should be fitted to the equipment/system being tested, set to relieve at a pressure that will prevent over pressurization.
- Sufficient venting / draining points shall be provided in order to prevent trapping of pressurizing medium behind non-return valves, check valves, between isolation valves, or within dead legs of the pressure envelope.
- The equipment/plant to be pressure tested must be subjected to thorough examination prior to testing. It may be necessary to 100% inspect all welds using visual, radiographic or other NDT techniques.
- The gas supply must be isolated when test pressure has been achieved.
- The pressure envelope must contain sufficient vents, to a safe location.
- De-pressurization after pneumatic testing must be gradual.

12.15. **Barricades and Warning Signs**

- g. Area where work is being carried out above man height or below 1' ground depth must be barricaded. Linked barrier with link chains must be provided by the contractor for cordoning the area at ground level, during GI work.
- h. Follow the instruction of all types of warning signs like "NO SMOKING" "NO ENTRY" "DANGER" "Work at height", "Inconvenience to member of public regretted/work in progress", "Name of the Contractor and contact details"

12.16. **Basic Safety Rules For The Construction Site**

- The construction site shall be considered a restricted area and unauthorized entry into the site is strictly prohibited. Anyone found trespassing should be asked to leave the site immediately.
- All persons of CLIENT/Consultant/Contractor shall be responsible for their own safety in plant or work sites.
- Nobody authorized to touch any valve, switch, or interfere with plant / site activities.
- Children below 18 years are not allowed inside plant / work site.
- Never walk on the pipes, equipment, structures etc.
- Always use stairs, handrails & walkover platforms.
- Never carry sharp or pointed tools in pockets.
- Alcoholic beverages will not be consumed, brought into, or manufactured on the work sites or inside the plant.
- Drugs /intoxicant substances will not be used, brought into, or manufactured on the site or plant.
- Cigarette, beedi smoking is not allowed except in the designated smoking booths.
- Firearms, explosives, knives or other types of weapons will not be allowed on the site.
- Gambling or any other form of betting games is prohibited.
- Discrimination on the basis of race, sex or national origin is prohibited.
- Horseplay, Fight, Practical jokes, Aggressive or abnormal behaviour is prohibited.

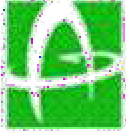

CITY GAS DISTRIBUTION PROJECT TENDER FOR PNG I&C CONNECTIONS

- c) Individuals under the influence of alcohol or drugs will not be permitted entry to the site.
- d) Safety helmet, safety shoes, ear plug or ear muff, hand gloves, safety goggles, safety harness & clothing for body protection are mandatory in the plant or work site.
- e) Use other personal protective equipment as displayed in plan / site.
- f) It is strictly not allowed to use non-intrinsically safe equipment or instruments in the operational area of site.
- g) All vehicles for use on the site shall conform to the requirements of the Vehicle Entry Permit. Maximum Speed limit inside complex is 10 km/Hr.
- h) In case of Emergency dial appropriate agency like Fire, Hospital, Security etc as displayed.

Violation of the Rules and Regulations might result in removing the person(s) concerned from the premises and denying the person(s) concerned from any future access to the site. The site in-charge will judge whether permanent removal of the individual from the premises is justified depending on the seriousness of the violation(s). All Indian laws shall be complied with at all the time.

12.17. **Site Emergency Preparedness and Response**

The CONTRACTOR shall establish, what are the arrangements in the event of an emergency.

The CONTRACTOR shall ensure that their Personnel are familiar with the essential emergency equipment, the use of which shall be demonstrated and practiced in drills.

The CONTRACTOR shall check the emergency procedures and the location and condition of the emergency equipment.

The CONTRACTOR personnel will be instructed of the actions to take in the event of serious personal injury, gas or toxic release, fire, explosion, heavy rains, wind storms, chemical spillage, land slide, scaffolding or structure collapse, critical damage to operating equipment, etc. and other emergency situations during the induction training and other ongoing training sessions.

These situations may demand adequate rescue and relief measure to handle such events quickly and effectively.

In an emergency, or on hearing the alarm, every supervisor shall ensure the following;

- 2. All work is stopped at once.
- 3. All equipment vehicles and tools are shut down (all sources of ignition).
- 4. All men are evacuated to a pre-determined Muster point.
- 5. A roll call is taken and every man is accounted for.
- 6. No one is permitted to return to work until notification has been received from the CONTRACTOR representative that it is safe to do so.

12.17.1. **Emergency Preparedness**

The basic and essential features of any emergency Preparedness are to analyses and plan for the potential risk. This includes;

- 5. Establishing and maintaining effective communications.
- 6. Liaison with local emergency services and authorities.



CITY GAS DISTRIBUTION PROJECT TENDER FOR PNG I&C CONNECTIONS

Action Procedure (evacuation routes and assembly points etc.).

G. Appointment of key personnel and specifying their duties and responsibility.

H. Emergency Response Drills

12.17.2. Emergency Response Drills

Effectiveness and comprehensiveness of Emergency Response Plan must be tested on a regular basis. Drills which reflect the conditions induced from the more likely emergency occurrences must be conducted. CONTRACTOR should conduct such drill on periodic basis. All emergency drills, exercises and responses to actual incidents shall be fully documented and followed by a complete review and when necessary, procedure revision process.

Initiate any required procedural changes, and initiate the dissemination of any lessons learned through the Site HSE communication system.

12.18. Road Safety Norms

11. For roadside working site to be barricaded.
12. Only eligible driver can drive required vehicle inside site
13. Speed limit norms of site must be followed
14. No riding or travelling on the back of open-end vehicle, fork lift or trailers should be done.

12.19. Environment

The CONTRACTOR shall pay due regard to the environment by preserving air, water, soil, animal and plant life from adverse effects of the CONTRACTOR's activities and minimizing any nuisance which may arise from such operations.

All waste generated by the CONTRACTOR shall be contained and disposed of in accordance with the legal requirement on waste management.

12.20. Labour Welfare & Legal Requirement

5. All mandatory provisions with regard to safety as prescribed under contract Labor (Abolition & Regulation) Act 1970 and Rules made there under are applicable.
6. Workmen compensation insurance and registration under ESI should be maintained.
7. Time to time, all rules and regulations suggested by safety committee of site must be followed and implemented

Σ Σ



**CITY GAS DISTRIBUTION PROJECT
TENDER FOR PNG I&C CONNECTIONS**

ANNEXURE – A

RELEVANT IS-CODES FOR PERSONNEL PROTECTION

IS : 2925 – 1984	:	Industrial Safety Helmets.
IS : 4770 – 1968	:	Rubber gloves for electrical purposes
IS : 6994 – 1973 (Part – I)	:	Industrial Safety Gloves (Leather & Cotton)
IS : 1989 – 1986 (Part – I & III)	:	Leather safety boots and shoes
IS : 3738 – 1975	:	Rubber knee boots
IS : 5557 – 1969	:	Industrial and Safety rubber knee boots
IS : 6519 – 1971	:	Code of practice for selection, care and repair of Safety footwear
IS : 11226 – 1985	:	Leather Safety footwear having direct molding sole
IS : 5983 – 1978	:	Eye protectors
IS : 9167 – 1979	:	Ear protectors.
IS : 3521 – 1983	:	Industrial Safety belts and harness

Σ Σ Σ



ANNEXURES

ANNEXURE – B

FORMAT - 1.0

1.0 : HEALTHY, SAFETY & ENVIRONMENT (HSE) PLAN

Project:

Contractor:

Date:

Owner:

(To be prepared & submitted by each Contractor)

Activity Description	Procedure/ W.I./ Guidelines	Code of Conformance	Performing Function			Audit Function
			Performance	Checker	Approver	Customer Review/ Audit Requirements

PREPARED BY

REVIEWED

APPROVED BY



**CITY GAS DISTRIBUTION PROJECT
TENDER FOR PNG I&C CONNECTIONS**

2.0 MONTHLY CHECKLIST CUM COMPLIANCE REPORT REGARDING HSE (1/4)

Project: _____

Contractor : _____

Date: _____

Owner : _____

Inspection By: _____

Note: write 'NC' (Not Concern) wherever any of the items are not applicable

Item	Yes	No	Remarks	Action
HOUSEKEEPING				
Waste containers provided and used				
Sanitary facilities adequate and Clean				
Passageways and Walkways Clear				
General neatness of working areas				
Proper Material Storage				
Wooden Boards properly stacked and nails removed				
Cords, leads out of walk and traffic ways				
Scraps removed from the work site				
Other				
PERSONNEL PROTECTIVE EQUIPMENT				
Goggles : Shields				
Face protection				
Hearing protection				
Safety Shoes provided				
Hand protection				
Respiratory Masks etc.				
FullBody Harness Belts				
Safety Helmets				
Fall Arrestors				
LIFELINE ROPES				
Other				

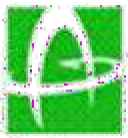

**CITY GAS DISTRIBUTION PROJECT
TENDER FOR PNG I&C CONNECTIONS**

MONTHLY CHECKLIST CUM COMPLIANCE REPORT REGARDING HSE (2/4)

Item	Yes	No	Remark	Action
Welding Cutting				
Valid work permit				
Flashback arrester provided for cylinders				
Power cable crossing the welding cable				
Adequate earthing provided				
No combustible materials kept near welding & cutting works				
Gas cylinder chained upright & kept in trolleys				
Cables and hoses not obstructing				
Screens or shields used				
Flammable materials protected				
Fire extinguisher (s) accessible				
Other				
SCAFFOLDING				
Fully decked platform				
Guard and intermediate rails in place				
Toe boards in place & tied properly				
Adequate shoring				
Adequate access				
Other				
LADDERS				
Extension side rails 1 m above				
Top of landing				
Properly secured at top & bottom				
Angle $\pm 70^\circ$ from horizontal				
Other				



**CITY GAS DISTRIBUTION PROJECT
TENDER FOR PNG I&C CONNECTIONS**

MONTHLY CHECKLIST CUM COMPLIANCE REPORT REGARDING HSE(3/4)

Item	Yes	No	Remark	Action
TEMPORARY FACILITIES				
Emergency instruction posted				
Fire extinguishers provided				
Fire-aid equipment				
Secured against storm damage				
General nemeses				
In accordance with electrical requirements				
Other				
Fire Prevention				
Personnel instructed				
Fire extinguishers checked				
No smoking in prohibited areas				
Hydrants clear				
Other				
ELECTRICAL				
Proper wiring & earthing				
ELCB's provided				
Ground fault circuit interruptors				
Prevention of tripping hazards				
Proper electrical cable joints				
Light poles secured				
Clear way to power distribution board				
Proper rating of fuses				



**CITY GAS DISTRIBUTION PROJECT
TENDER FOR PNG I&C CONNECTIONS**

MONTHLY CHECKLIST CUM COMPLIANCE REPORT REGARDING HSE (4/4)

Item	Yes	No	Remark	Action
HANDLING AND STORAGE OF MATERIALS				
Properly stored or stacked				
Passageways clear				
Other				
FLAMMABLE GASES AND LIQUIDS				
Containers clearly identified				
Proper storage				
Fire extinguishers nearby				
Other				
WORKING AT HEIGHT				
Erection plan				
Safety nets				
Safety belts tied properly				
Illumination				
No loose material at height				
Nobody under working area				
All openings covered				
Other				
ENVIRONMENT				
Chemical and other Effluents properly disposed				
Cleaning liquid of pipes disposed off properly				
Seawater used for Hydrotesting disposed off as per agreed proceeding				
Lubricant Waste/ Engine oils properly disposed				
Waster from Canteen office, sanitation etc. disposed properly				
Disposal of surplus earth stripping materials, Oily rags and combustible materials done properly				
Green belt protection.				

Signature of Resident
Engineer with Seal



**CITY GAS DISTRIBUTION PROJECT
TENDER FOR PNG I&C CONNECTIONS**

**Monthly Health, Safety & Environmental (HSE) Report
(To be submitted by each Contractor)**

Actual work start date: _____ For the month of: _____
 Project: _____ Report No.: _____
 Name of the Contractor: _____ Status as on: _____
 Name of Work: _____ Name of Safety officer: _____

Item	This Month	Cumulative
Total strength (Staff – Workmen)		
Number of HSE meeting organised at site		
Number of HSE awareness programmes conducted at site		
Whether workmen compensation policy taken	Y/N	
Whether workmen compensation policy valid	Y/N	
Whether workmen registered under ESI Act	Y/N	
Number of Fatal Accident		
Number of Loss Time Accident (Other than Fatal)		
Other accident (non loss time)		
Total No. of accident		
Total man-hours worked		
Man-hour loss due to fire and accident		
Compensation cases raised with insurance		
Compensation cases resolved and paid to workmen		

Remark

Date: ____ / ____ / ____

Safety Officer/RCM
(Signature and name)

To: OWNER..... 1 COPY
RCM/SITE-IN-CHARGE 1 COPY



**CITY GAS DISTRIBUTION PROJECT
TENDER FOR PNG I&C CONNECTIONS**

SUPPLEMENTARY ACCIDENT, INCIDENT & NEAR MISSREPORT

Project: _____ Supplementary to Report No.: _____

(Copy enclosed)

Site: _____ Date: _____

Contractor: _____

NAME OF THE INJURED.....
FATHER'S NAME.....
SUB-CONTRACTOR M/S.....
DATE & TIME OF ACCIDENT.....
LOCATION.....

BRIEF DESCRIPTION & CAUSE OF A ACCIDENT

NATURE OF INJURY / DAMAGE

COMMENTS FROM MEDICAL PRACTITIONER WHO ATTENDED THE VICITIM/INJURED

SUGGESTED IMPROVEMENT IN THE WORKING CONDITION IF ANY

LOSS OF MANHOURS AND IMPACT ON SITE WORKS

ANY OTHER COMMENT BY SAFETY OFFICER

Date : ____ / ____ //

SIGNATURE OF CONTRACTOR WITH SEAL

To : OWNER..... 1 COPY
: RCM/SITE-IN-CHARGE 1 COPY



**CITY GAS DISTRIBUTION PROJECT
TENDER FOR PNG I&C CONNECTIONS**

ACCIDENT REPORT

(TO BE SUBMITTED BY CONTRACTOR AFTER EVERY ACCIDENT WITHIN 2 HOURS OF ACCIDENT)

Report No. _____

Date: _____

Name of Site: _____

COTRACTOR _____

NAME OF THE INJURED

FATHER'S NAME.....

SUB-CONTRACTOR M/S.....

DATE & TIME OF ACCIDENT.....

LOCATION.....

BRIEF DESCRIPTION OF ACCIDENT

CAUSE OF ACCIDENT

NATURE OF INJURY / DAMAGE

MEDICAL AID PROVIDED / ACTIONS TAKEN

INTIMATION TO LOCAL AUTHORITIES

Date: ____ / ____ //

SIGNATURE OF CONTRACTOR WITH SEAL

To : OWNER..... 1 COPY
: RCM/SITE-IN-CHARGE 1 COPY

Σ Σ Σ

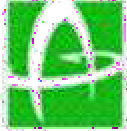

**CITY GAS DISTRIBUTION PROJECT
TENDER FOR PNG I&C CONNECTIONS**

APPROVED VENDOR LIST

ITEM CODE / DESCRIPTION	GI PIPE
VENDOR NAME	Remark
M/s Swastik Pipe Ltd.	
M/s Jindal Industries Ltd.	
M/s Vishal Pipes Ltd.	
M/s Indus Tubes Ltd.	
M/s Advance steel Tubes Ltd.	
M/s Good Luck Tubes Ltd.	
ITEM CODE / DESCRIPTION	GI fittings
VENDOR NAME	REMARKS
M/s Sarin Industries Ltd.	
M/s Jupiter Metal Industries Ltd.	
M/s Jainsons Industries Ltd.	
ITEM CODE / DESCRIPTION	Copper tubes & Fittings
VENDOR NAME	REMARKS
M/s Rajco metal	
M/s Mehta tubes	
ITEM CODE / DESCRIPTION	Brass Fittings
VENDOR NAME	REMARKS
M/s Chandan Enterprises	
M/s Paras Industries Ltd.	
ITEM CODE / DESCRIPTION	Corrugated Flexible Metal
VENDOR NAME	REMARKS
M/s KPC Flex Tubes	
M/s Vestas Hose Division	
M/s Alfa Flexi tubes	
ITEM CODE / DESCRIPTION	MDPE FITTING
VENDOR NAME	REMARKS
M/s George Fisher	
M/s Kimplas Piping Systems.	
ITEM CODE / DESCRIPTION	WARNING MAT
VENDOR NAME	REMARKS
M/s. Bina Enterprises	
M/s Singhal Industries.	
ITEM CODE / DESCRIPTION	Regulators (100 to 21 milli bar)/SR
VENDOR NAME	REMARKS (SR- Service Regulator)
M/s Raychem	
M/s Measure Nirmal (Regulator)/M/s Nirmal (SR)	
M/s Green Globe	
ITEM CODE / DESCRIPTION	Steel Re-inforced Rubber Hose(Type-4)
VENDOR NAME	REMARKS
M/s Super Seal Flexible Hose Ltd.	
M/s Suraksha Products Pvt. Ltd.	
M/s Vansh Industries	
M/s T & L Gases	

SKETCH OF REGULATOR BOX
BRACKETS & CLAMPS

DRAWING NO.

W6J-01-P-0-103

SHEET NO.

1 OF 1

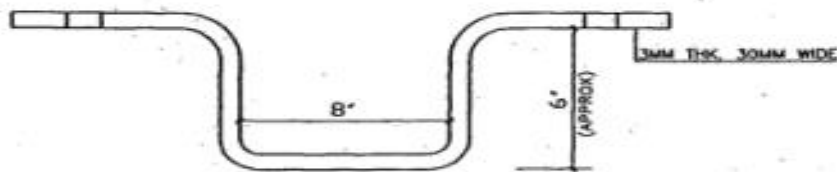
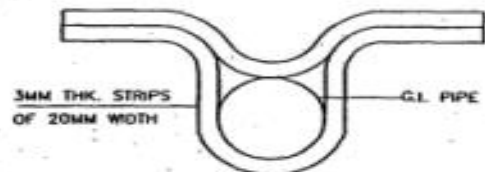
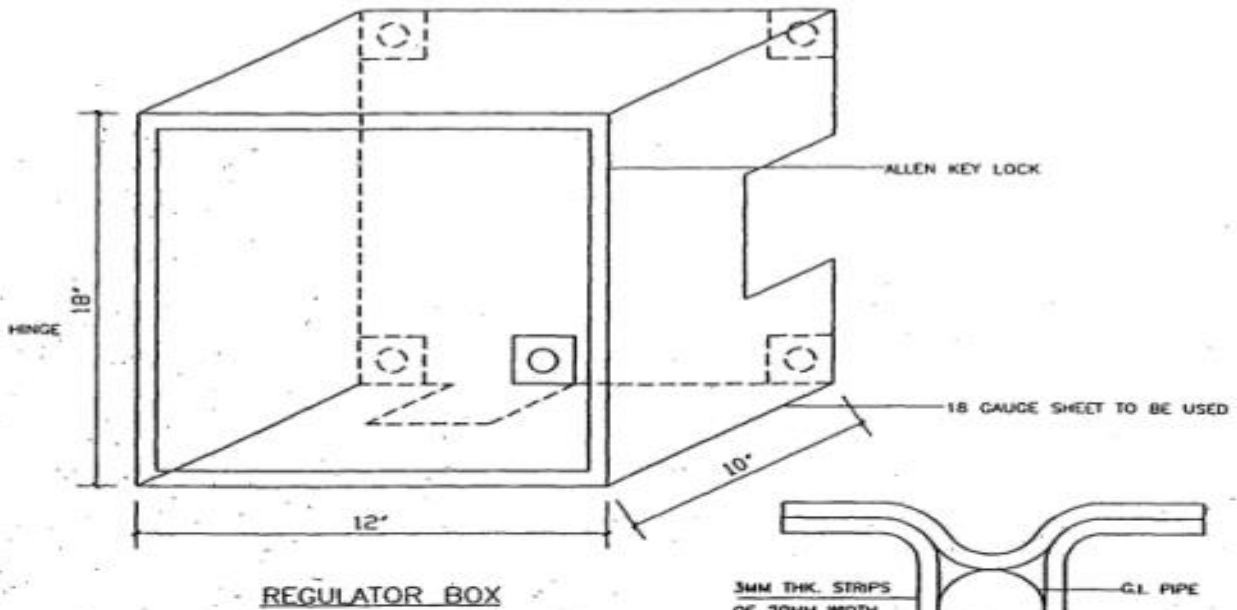

CLAMP FOR PIPE

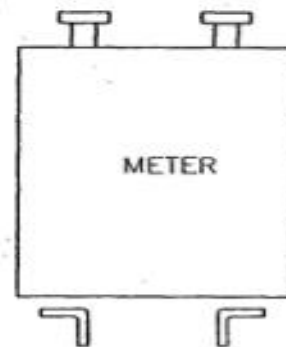

ANGLE BRACKETS 50x50MM
SMALL COMMERCIAL

NOTES:

1. CLAMP, REGULATOR BOX AND METER BRACKET ARE TO BE MADE AS PER DIRECTION AND APPROVAL OF EIC.
2. CLAMP/BOXES BRACKETS TO BE TIGHTLY SECURED TO THE WALL & PROPER ROWEL PLUGS, SCREWS ECT, WOODEN BLOCKS TO BE USED IN CASE ROWEL PLUGS DO NOT HOLD. PROPER THE AREA.
3. PAINTING WITH ONE COAT OF ZINC PRIMER AND THREE COATS OF SYNTHETIC ENAMEL PAINT OF REPUTED MAKE (ASIAN PAINT, BERGER, NEROCAC) TO BE USED.
4. CLAMPS ON PIPES TO BE FIXED AT MAXIMUM DISTANCE OF 2 METERS AND AT BENDS.

B	25-08-00	ISSUED FOR TENDER	NJ	SK	DK DEY
A	14-08-06	ISSUED FOR COMMENT	NJ	SK	DK DEY
REV. NO.	DATE	SUBJECT OF REVISION	DRAWN	CHECKED	APPROVED

STANDARD DETAIL FOR
WARNING PLATE MARKER
W/O FOUNDATION

DRAWING NO.

WGI-01-P-0-101

SHEET NO.

1 OF 1

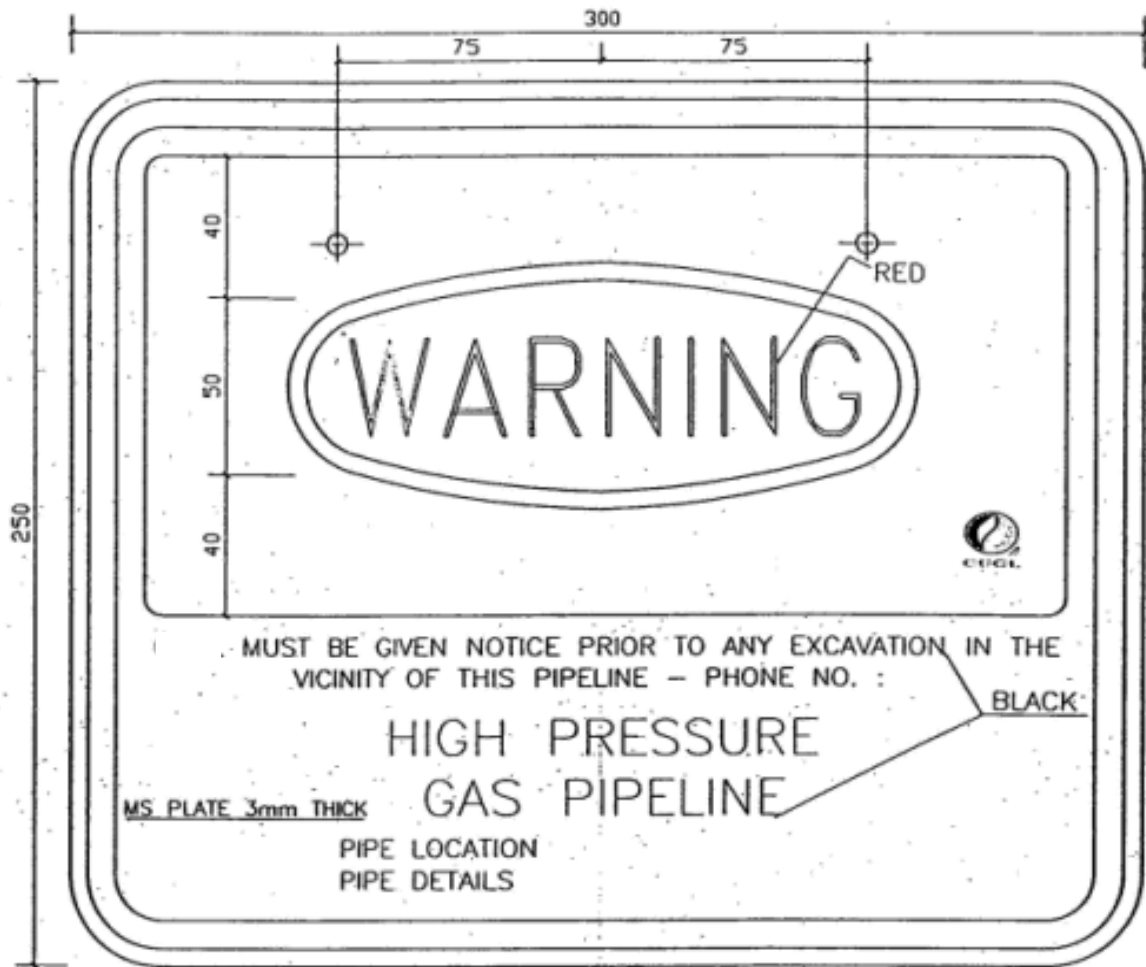

FOR TENDER PURPOSE

NOTES:

1. The full wording and sizes are only indicative and are subject to the approval by engineer-in-charge before fabrication
2. Scheme for painting and colouring.
— One coat of primer & two coats of specified paints.
— All letters except "warning" to be painted black.
3. All dimensions are in mm. Unless otherwise specified.
4. Plate shall be painted with 250 wide alternate bands of black and white paint.

B	25-08-06	ISSUED FOR TENDER PURPOSE	NJ	SK	OK DEY
A	14-08-06	ISSUED FOR COMMENT.	NJ	SK	OK DEY
REV. NO.	DATE	SUBJECT OF REVISION	DRAWN	CHECKED	APPROVED



TYPICAL TRENCH DETAILS
FOR CITY GAS
DISTRIBUTION

DRAWING NO.

WGI-0-19-005

PAGE NO.

1

WELL COMPACTED
BACK FILL

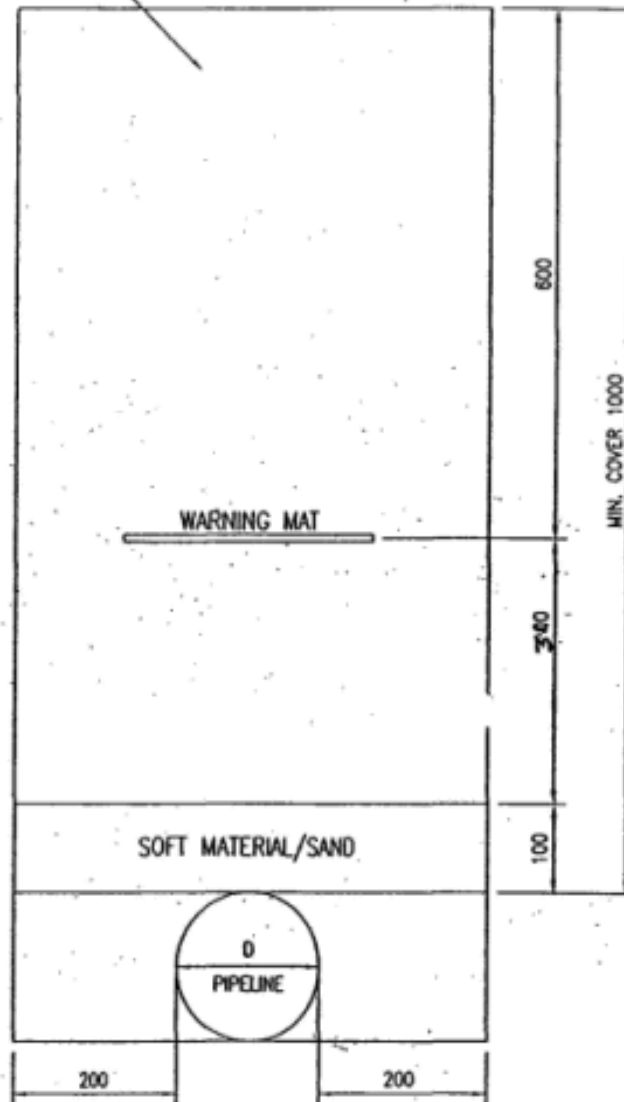

TRENCH IN NORMAL SOIL
TYPICAL SECTION

NOTES:-

- 1 ALL DIMENSIONS ARE IN MM.
- 2 THIS DRAWING IS NOT APPLICABLE FOR CROSSING OF UNDER GROUND UTILITIES, ROADS, CANALS, RAILWAYS ETC.

1	07.04.04	CLIENT'S COMMENTS INCORPORATED.	CHP	<i>Chen</i>	BP		V.V.A	
0	05.04.04	APPROVED.	CHP	<i>Chen</i>	BP	BP	V.V.A	V.V.A
REV. NO.	DATE	SUBJECT OF REVISION	DRAWN	CHECKED	APPROVED			

RCC PIT FOR PE STOP-OFF VALVE (Ø125 & 160mm)

DRAWING NO.

STD-19-142

PAGE NO.

2

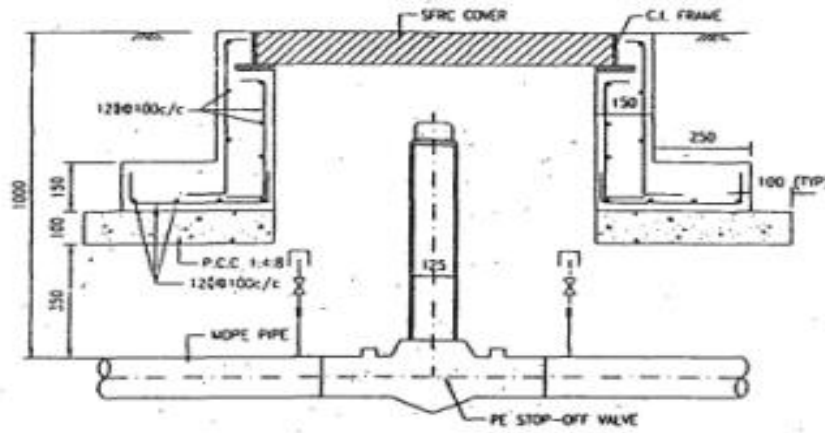

SECTION A-A

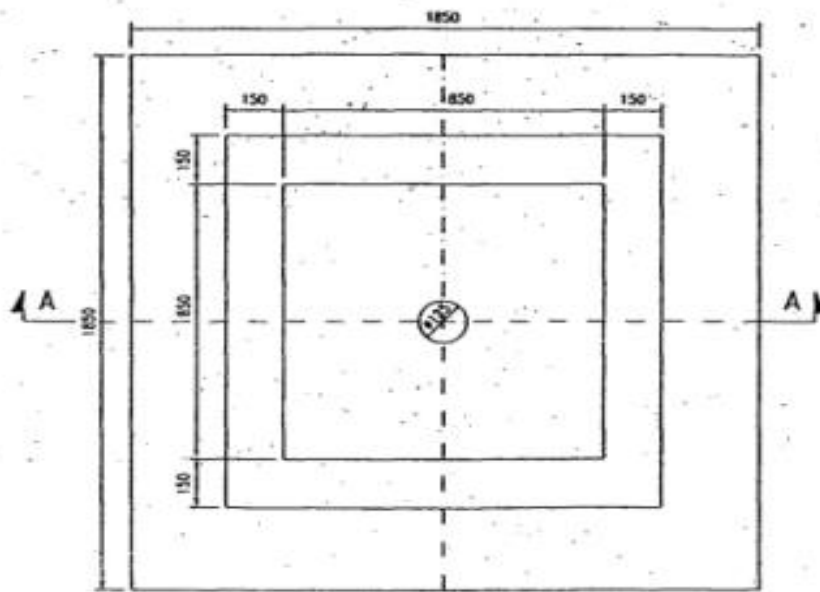

PLAN

NOTES:-

- 1 ALL DIMENSIONS ARE IN MILLIMETERS.
- 2 THE CONCRETE SHALL HAVE A CHARACTERISTIC STRENGTH OF 20N/mm
- 3 THE COVER FOR REINFORCEMENT SHALL BE 40mm ON OUTER FACES AND 25mm ON INNER FACES
- 4 THE SFRC COVER SHALL HAVE REINFORCED CONCRETE OF GRADE M-35 CONFORMED TO IS: 456-1978
- 5 DEBRIS BACKFILL TO BE REMOVED AND GOOD EARTH TO BE FILLED IN AREA OF 2.10M x 2.10M WITH PROPER COMPACTION AND CONSOLIDATION BY WATER

1	15.02.08	BASE SLAB DETAILS MODIFIED. APPROVED.	ATC	RJ	V.V.A
0	05.02.03	APPROVED.	ATC	RJ RJ	V.V.A V.V.A
REV. NO.	DATE	SUBJECT OF REVISION	DRAWN	CHECKED	APPROVED

RCC PIT FOR PE STOP-OFF VALVE (ø63 & ø90mm)

DRAWING NO.

STD-19-142

PAGE NO.

1

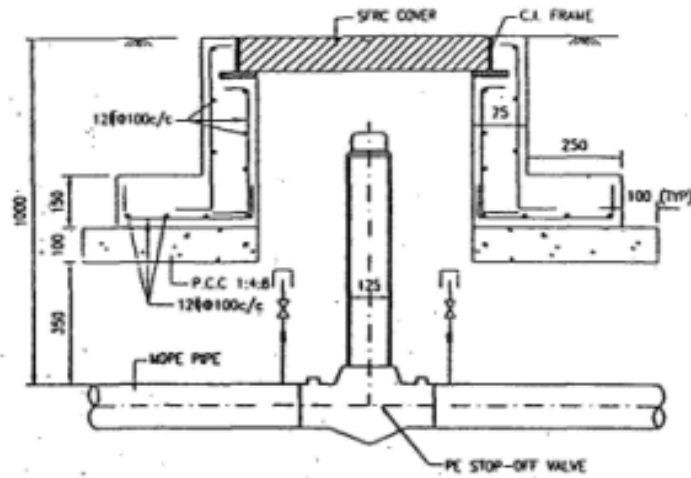

SECTION A-A

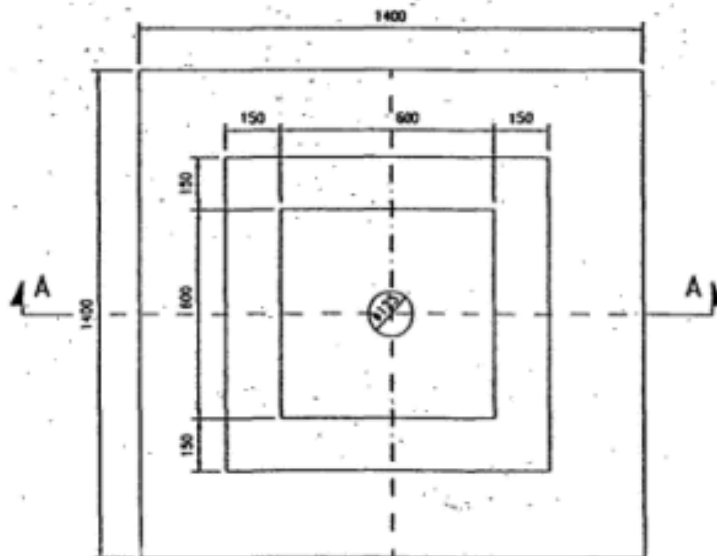

PLAN

NOTES:-

- 1 ALL DIMENSIONS ARE IN MILLIMETERS.
- 2 THE CONCRETE SHALL HAVE A CHARACTERISTIC STRENGTH OF 20N/mm
- 3 THE COVER FOR REINFORCEMENT SHALL BE 40mm ON OUTER FACES AND 25mm ON INNER FACES
- 4 THE S.F.R.C. COVER SHALL HAVE REINFORCED CONCRETE OF GRADE M-35 CONFORMED TO IS: 456-1978
- 5 DEBRIS BACKFILL TO BE REMOVED AND GOOD EARTH TO BE FILLED IN AREA OF 1.60M x 1.60M WITH PROPER COMPACTION AND CONSOLIDATION BY WATER

REV. NO.	DATE	SUBJECT OF REVISION	DRAWN	CHECKED	APPROVED
2	15.02.06	BASE SLAB DETAILS MODIFIED. APPROVED.	ATC	RJ	V.V.A
1	05.02.03	DIMENSIONS MODIFIED. APPROVED.	ATC	RJ	V.V.A V.V.A
0	20.09.02	APPROVED.	ATC	RJ	V.V.A V.V.A

SFRC COVER FOR PE
STOP-OFF VALVE PIT

DRAWING NO.

STD-19-144

PAGE NO.

1

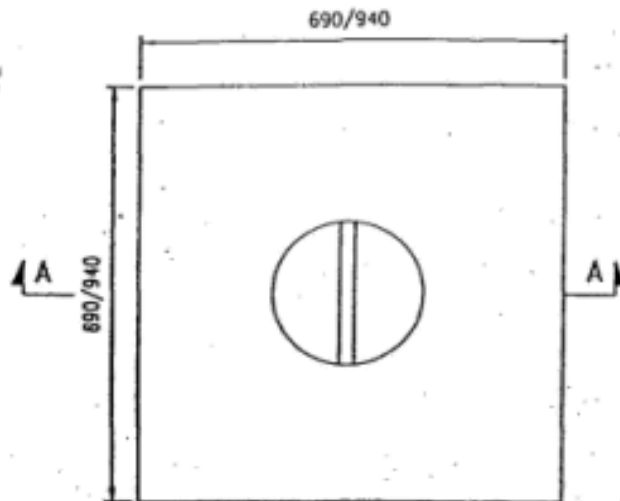

PLAN

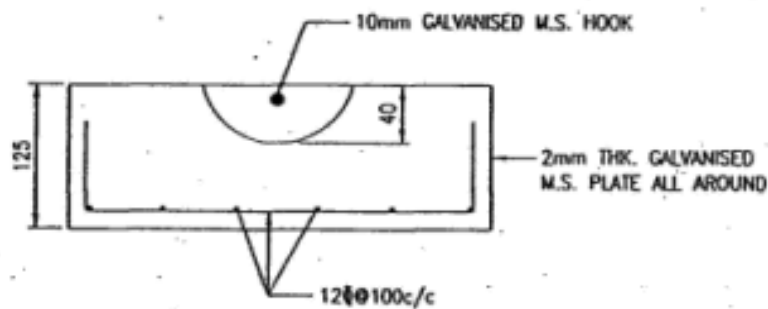

SECTION A-A

NOTES:-

- 1 ALL DIMENSIONS ARE IN MILLIMETERS.
- 2 THE SFRC COVER SHALL HAVE REINFORCED CONCRETE OF GRADE M-35 CONFORMED TO IS: 456-1978
- 3 HEAVY LOAD TEST : SUITABLE FOR 'A' CLASS LOADING
- 4 PERFORMANCE REQUIREMENTS-
 - (a) SAMPLING AND CRITERIA FOR CONFORMITY AS PER IS: 12592 (PART-1)-1998
 - (b) LOAD TEST AS PER OS: 12592 (PART-1)-1998
 - (c) INSPECTION AND MANUFACTURES GUARANTEE AS PER IS: 12592 (PART-1)-1998

REV. NO.	DATE	SUBJECT OF REVISION	DRAWN	CHECKED	APPROVED
2	15.02.06	SFRC COVER DETAILS MODIFIED. APPROVED.	ATC	RJ	V.V.A
1	05.02.03	DIMENSIONS MODIFIED. APPROVED.	ATC	RJ	V.V.A V.V.A
0	21.09.02	APPROVED.	ATC	RJ	V.V.A V.V.A

C.I. FRAME FOR SERC COVER
OF PE STOP-OFF VALVE PIT

DRAWING NO.

STD-19-145

PAGE NO.

1

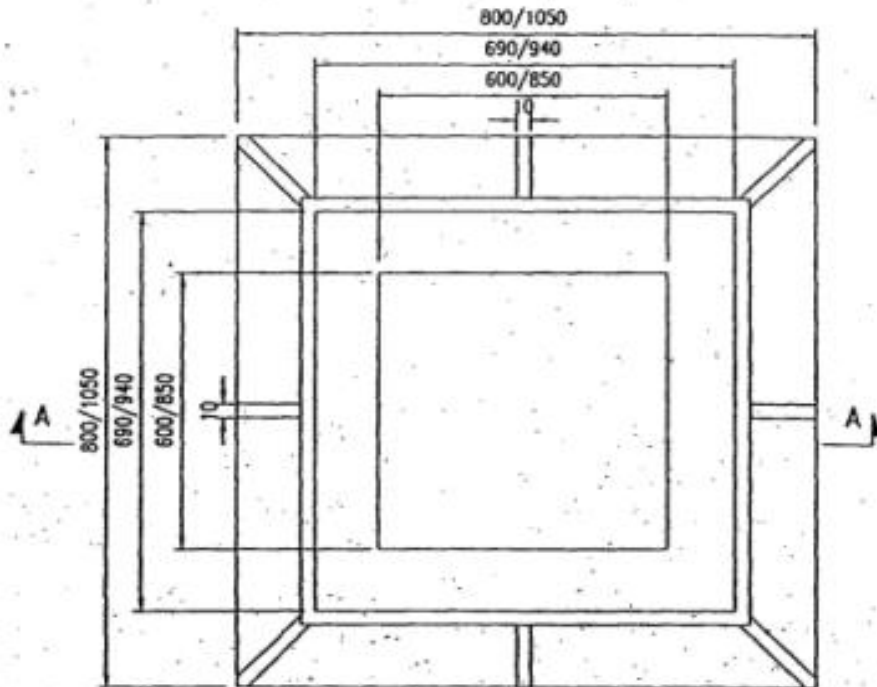

PLAN

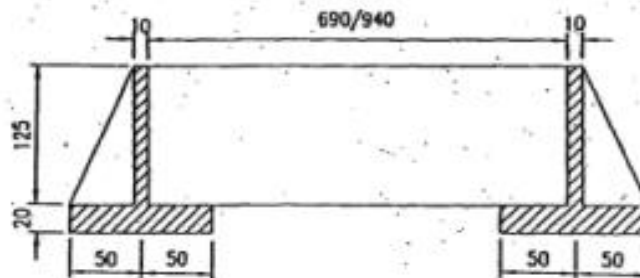

SECTION A-A

NOTES:-

- 1 ALL DIMENSIONS ARE IN MILLIMETERS.
- 2 GRADE FG150 OF IS 210 : 1978
- 3 HEAVYLOAD TEST : SUITABLE FOR 'A' CLASS LOADING.

2	15.02.03	SFRC COVER DETAILS MODIFIED. APPROVED.	ATC	RJ	V.V.A.	
1	05.02.03	DIMENSIONS MODIFIED. APPROVED.	ATC	RJ	RJ	V.V.A. V.V.A.
0	21.09.02	APPROVED.	ATC	RJ	RJ	V.V.A. V.V.A.
REV. NO.	DATE	SUBJECT OF REVISION	DRAWN	CHECKED	APPROVED	

ROAD/HIGHWAY CASED
CROSSING FOR MDPE PIPE

DRAWING NO.

WGS I-01-P-102

SHEET NO.

1 OF 1

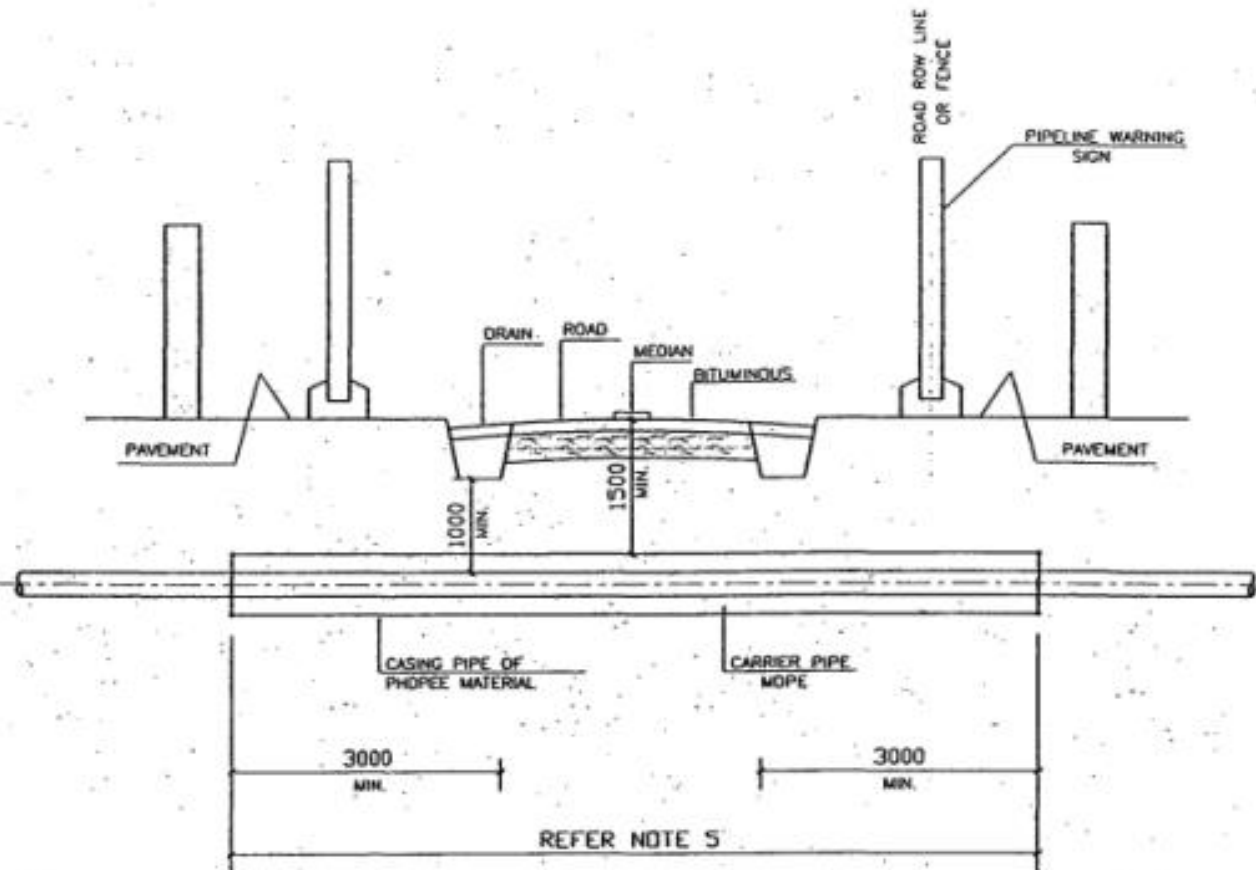

TYPICAL SECTION

FOR TENDER PURPOSE

NOTES:

1. ALL DIMENSIONS ARE IN MM UNLESS SPECIFIED OTHERWISE.
2. ROAD/ HIGHWAY CROSSING SHALL BE RESTORED TO ORIGINAL CONDITION TO THE ENTIRE SATISFACTION OF ENGINEER -IN-CHARGE AND CONCERNED AUTHORITIES HAVING JURISDICTION.
3. REFER API RP 1102 FOR OTHER DESIGN AND INSTALLATION REQUIREMENTS.
4. ANGLE OF INTERSECTION BETWEEN PIPELINE AND THE ROAD/ HIGHWAY SHALL BE AS CLOSE TO 90° AS POSSIBLE BUT IN NO CASE LESS THEN 30°.
5. CONTRACTOR SHALL VERIFY THE ACTUAL DIMENSIONS WITH RESPECT TO SURVEY DETAILS FOR EACH ROAD/HIGHWAY CROSSED AND PREPARE DETAILED DRAWING FOR INDIVIDUAL CROSSING FOR ENGINEER-IN-CHARGE APPROVED BEFORE COMMENCEMENT OF CONSTRUCTION
6. THE CASING PIPE SHALL BE ONE SIZE LARGER THAN THE MDPE CARRIER PIPE OR AS SPECIFIED BY ENGINEER-IN-CHARGE.

B	25-08-08	ISSUED FOR TENDER	NJ	SK	DK DEY
A	14-08-06	ISSUED FOR COMMENT	NJ	SK	DK DEY
REV. NO.	DATE	SUBJECT OF REVISION	DRAWN	CHECKED	APPROVED

BARRICADING

DRAWING NO.

STD-19-146

PAGE NO.

1

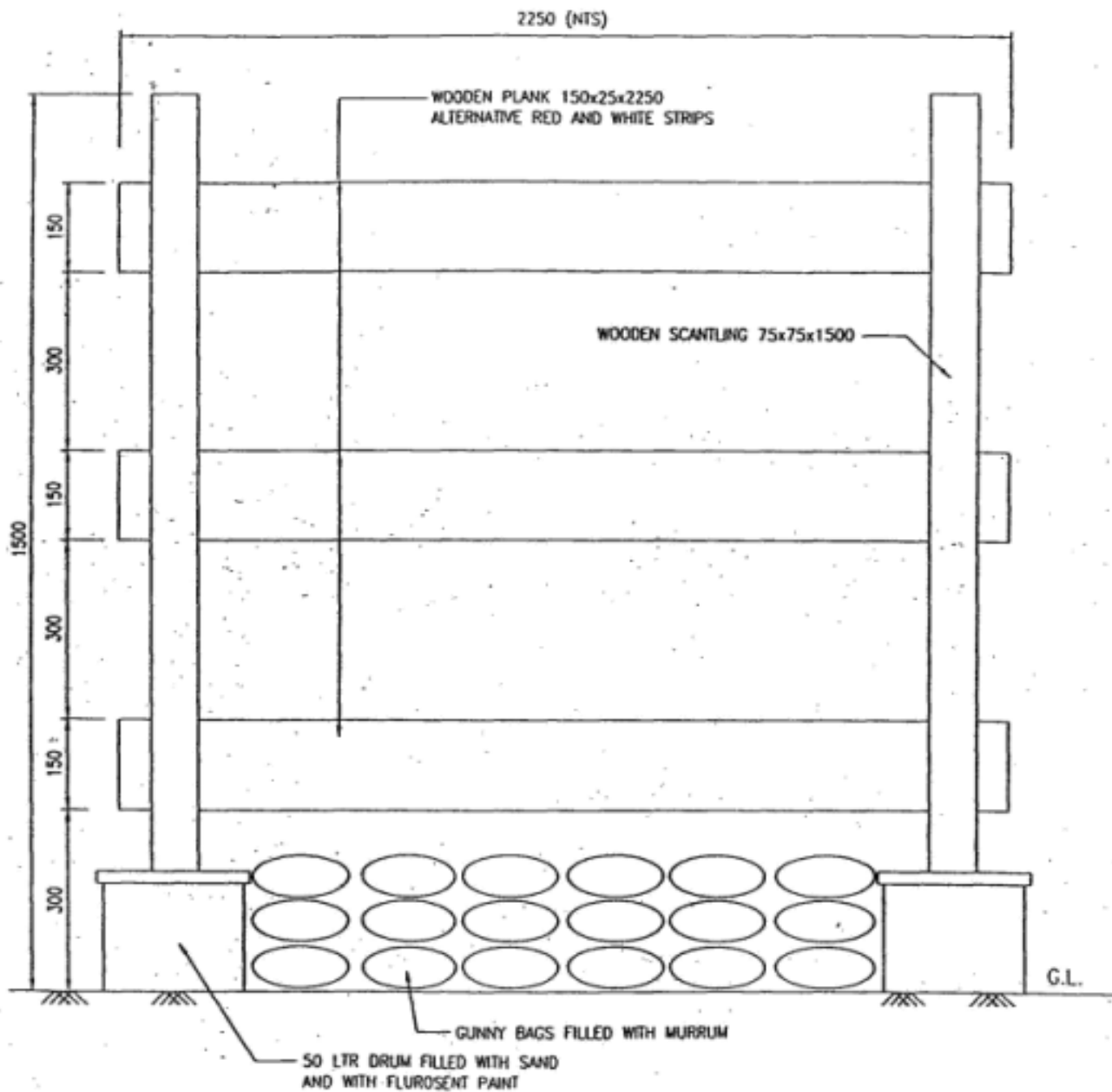

NOTES:-

1 ALL DIMENSIONS ARE IN MILLIMETERS.

0	21.09.08	APPROVED.	ATC	RJ	VYA
REV. NO.	DATE	SUBJECT OF REVISION	DRAWN	CHECKED	APPROVED

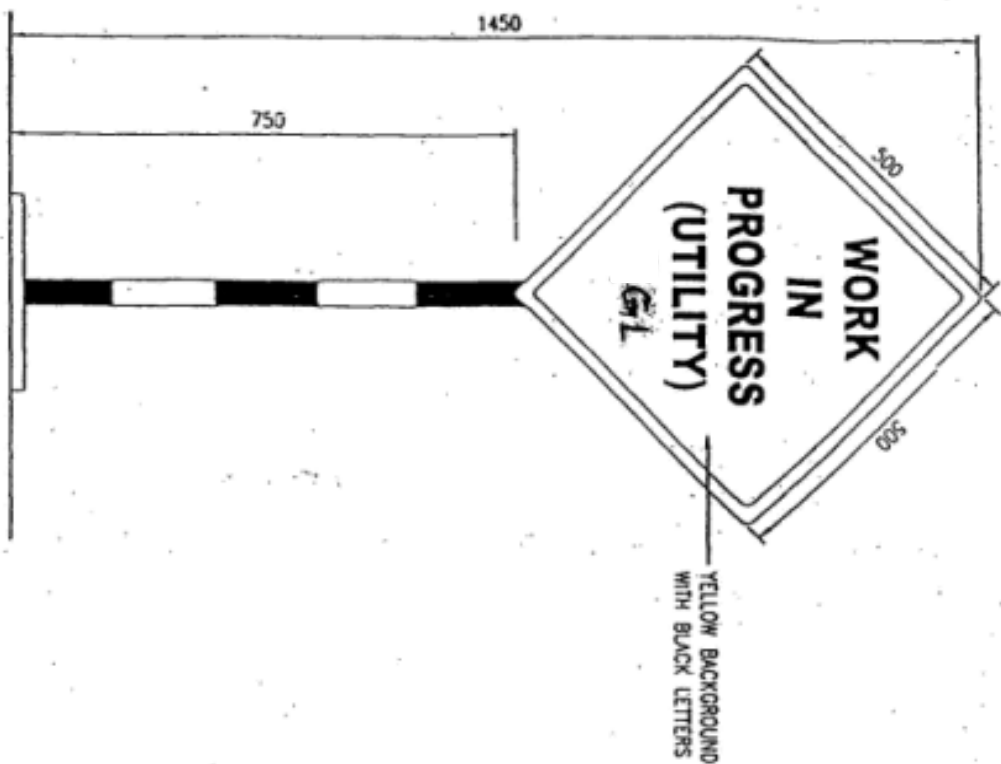

CAUTION BOARD

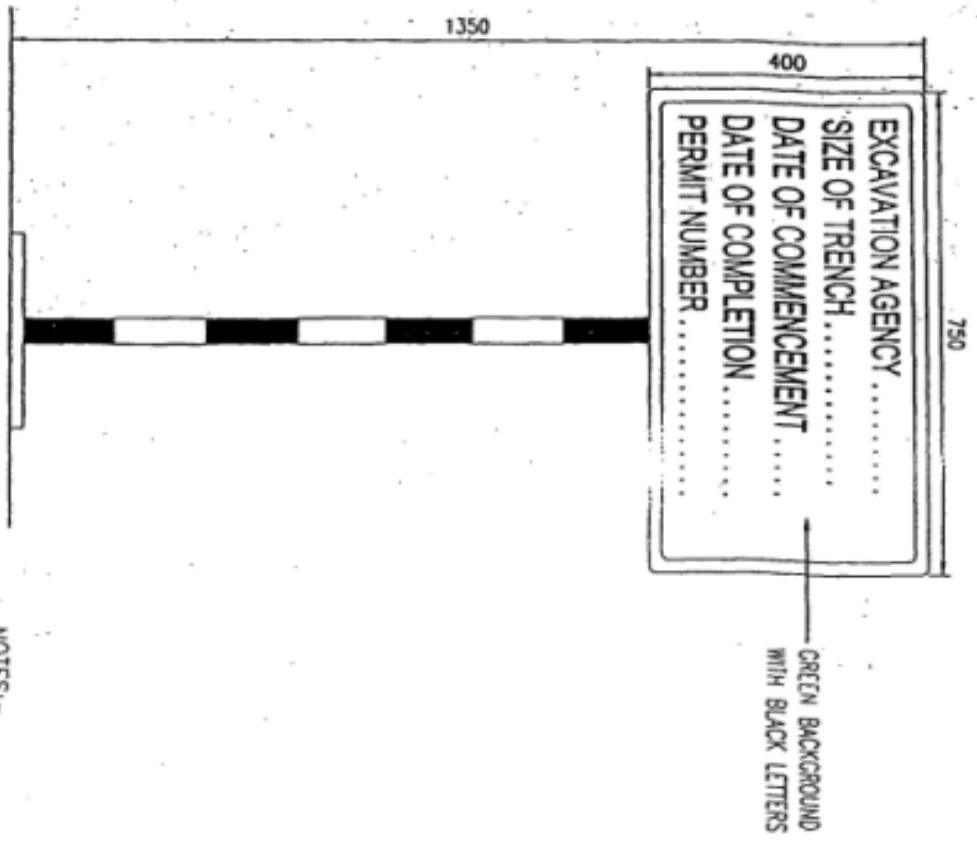

INFORMATION BOARD

NOTES:-

1 ALL DIMENSIONS ARE IN MILLIMETERS.

REV. NO.	DATE	SUBJECT OF REVISION		A.T.C.	DRAWN	CHECKED	APPROVED	SAFE SIGNING				DRAWING NO. STD-19-147			
0	20.09.09	APPROVED.													

REINFORCEMENT FOR EXCAVATION
CLOSER TO R.C.C ROAD SIDE

DRAWING NO.

STD-19-149

PAGE NO.

1

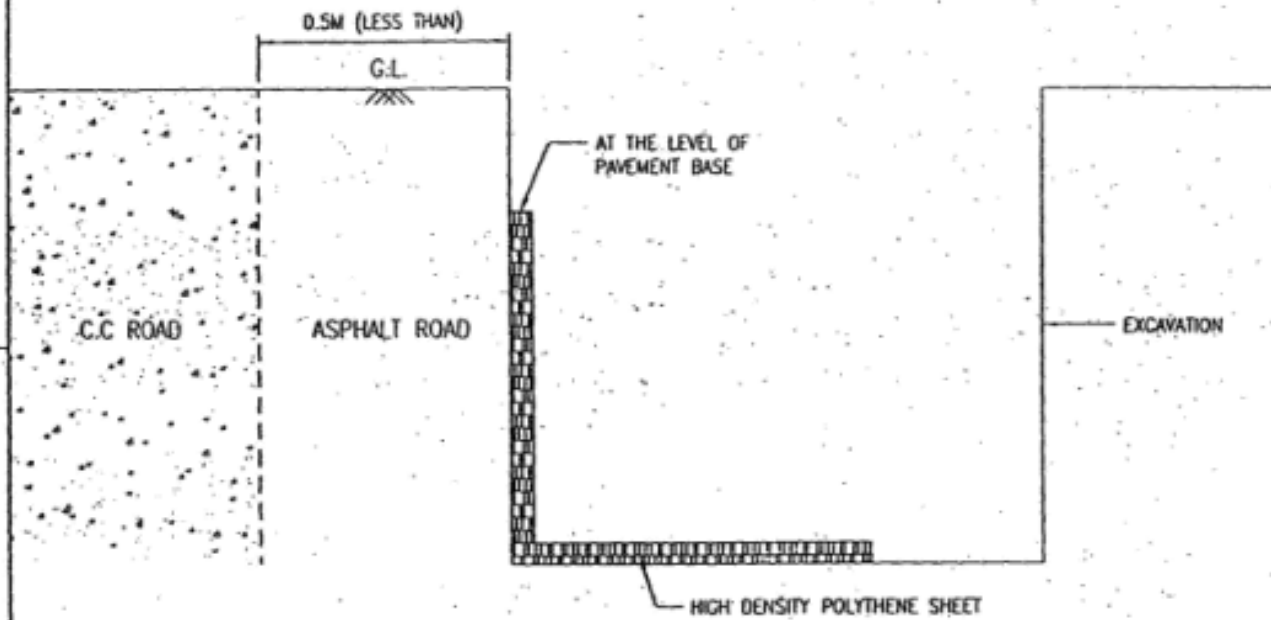

0	20.09.09	APPROVED.	ATC	RJ	V.V.A
REV. NO.	DATE	SUBJECT OF REVISION	DRAWN	CHECKED	APPROVED

TYPICAL TRENCH /
REINSTATEMENT DETAILS

DRAWING NO.

STD-19-152

PAGE NO.

1

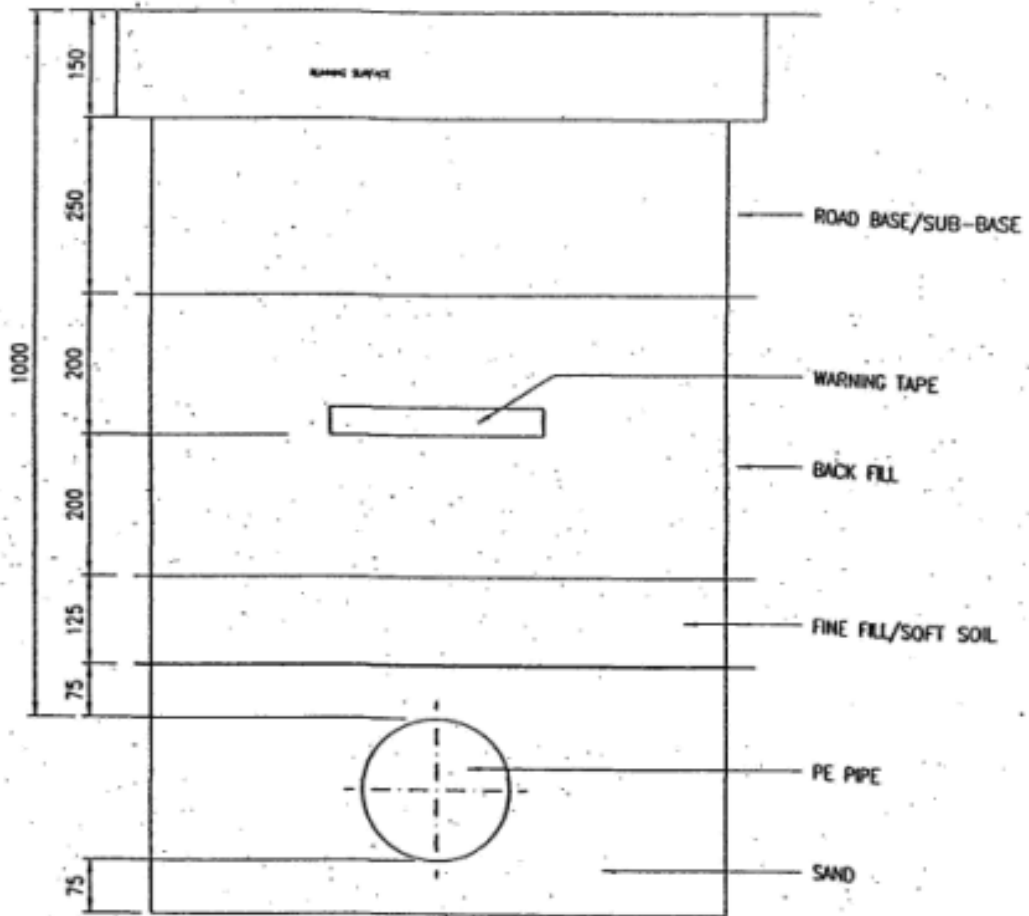

NOTES:-

1 ALL DIMENSIONS ARE IN MILLIMETERS.

0	20.09.08	APPROVED.	ATC	RJ	V.V.A
REV. NO.	DATE	SUBJECT OF REVISION	DRAWN	CHECKED	APPROVED

UNDERGROUND CABLE CROSSING

DRAWING NO.

TD-19-006

PAGE NO.

1

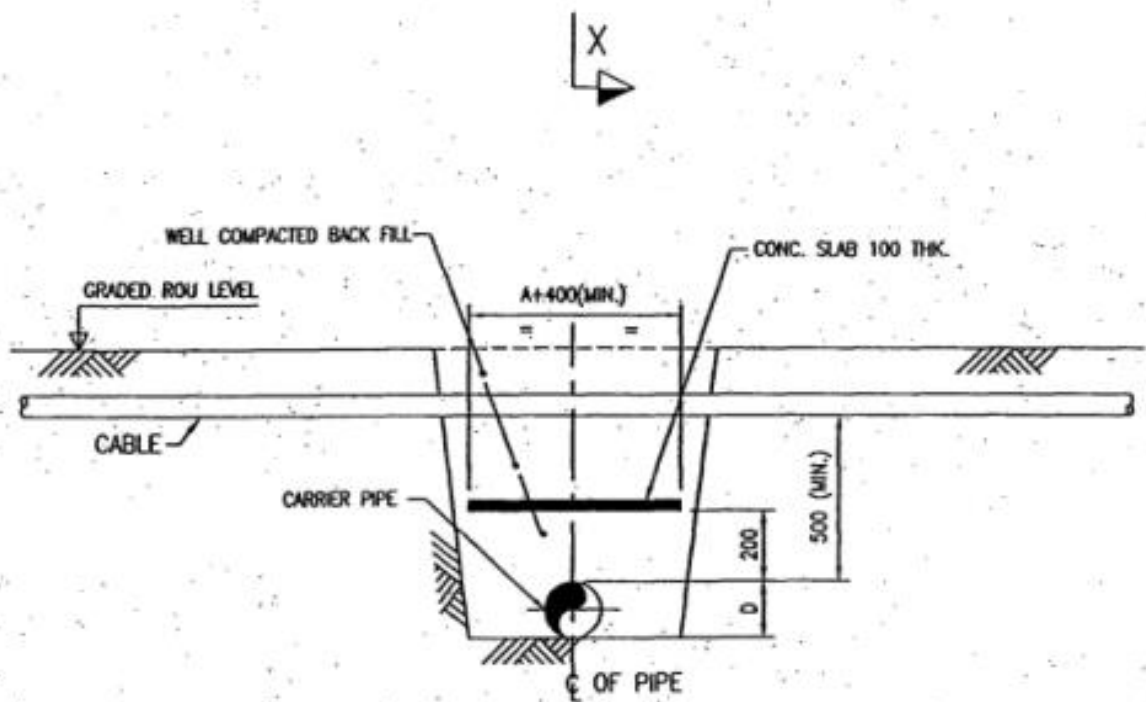
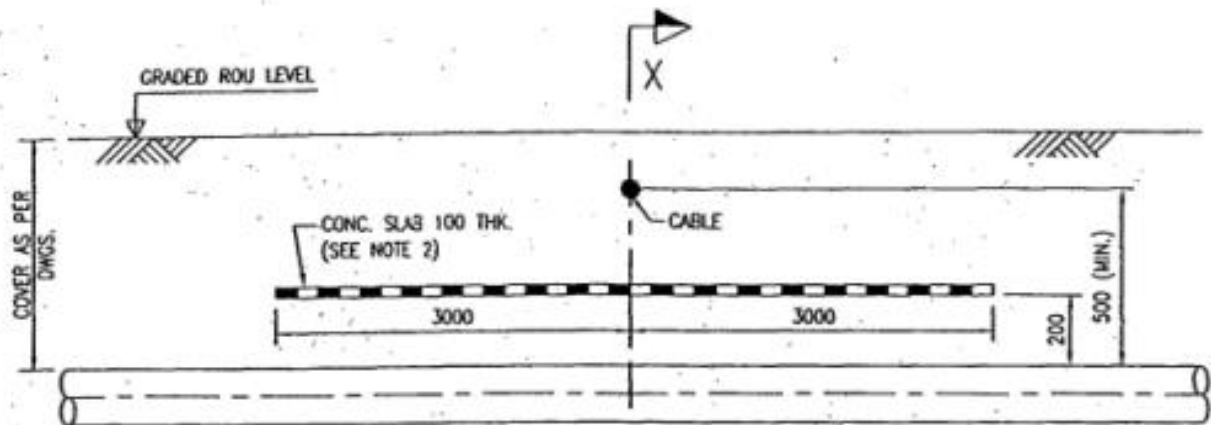

SECTION X-X

NOTES:-

1. ALL DIMENSIONS ARE IN MM UNLESS OTHERWISE STATED.
2. CONCRETE SLAB SHALL BE PCC M15 AS PER IS 456, 100THK.
3. A MODIFIED PIPELINE WARNING SIGN SHALL BE INSTALLED CLOSE TO THE CROSSING.
4. IN CASE OF ARMOURD AC CABLE, C.P. BONDING IS TO BE PROVIDED BETWEEN PIPELINE AND CABLE ARMOUR. IN CASE OF UNARMOURD CABLE, ARRANGEMENT FOR SHIELDING (BY PROVIDING CASING ON EITHER SIDE OF THE PIPELINE OR CABLE) SHALL BE CONSIDERED.
5. DIMENSION 'A' SHALL BE $A=D+500MM$.
6. TRENCH DIMENSIONS SHALL BE IN ACCORDANCE WITH RELEVANT STANDARDS/SPECIFICATIONS.
7. APPROVAL OF THE CROSSING SHALL BE OBTAINED FROM CONCERNED AUTHORITIES.

1	21.05.08	REVISED AS MARKED.	DM	<i>Singh</i>	KB		V.V.A	
0	21.11.01	APPROVED.	DM	<i>Singh</i>	KB	KB	V.V.A	V.V.A
REV. NO.	DATE	SUBJECT OF REVISION	DRAWN		CHECKED		APPROVED	

EXISTING UNDERGROUND PIPE CROSSING (TYPE-II)

DRAWING NO.

STD-19-023

PAGE NO.

1

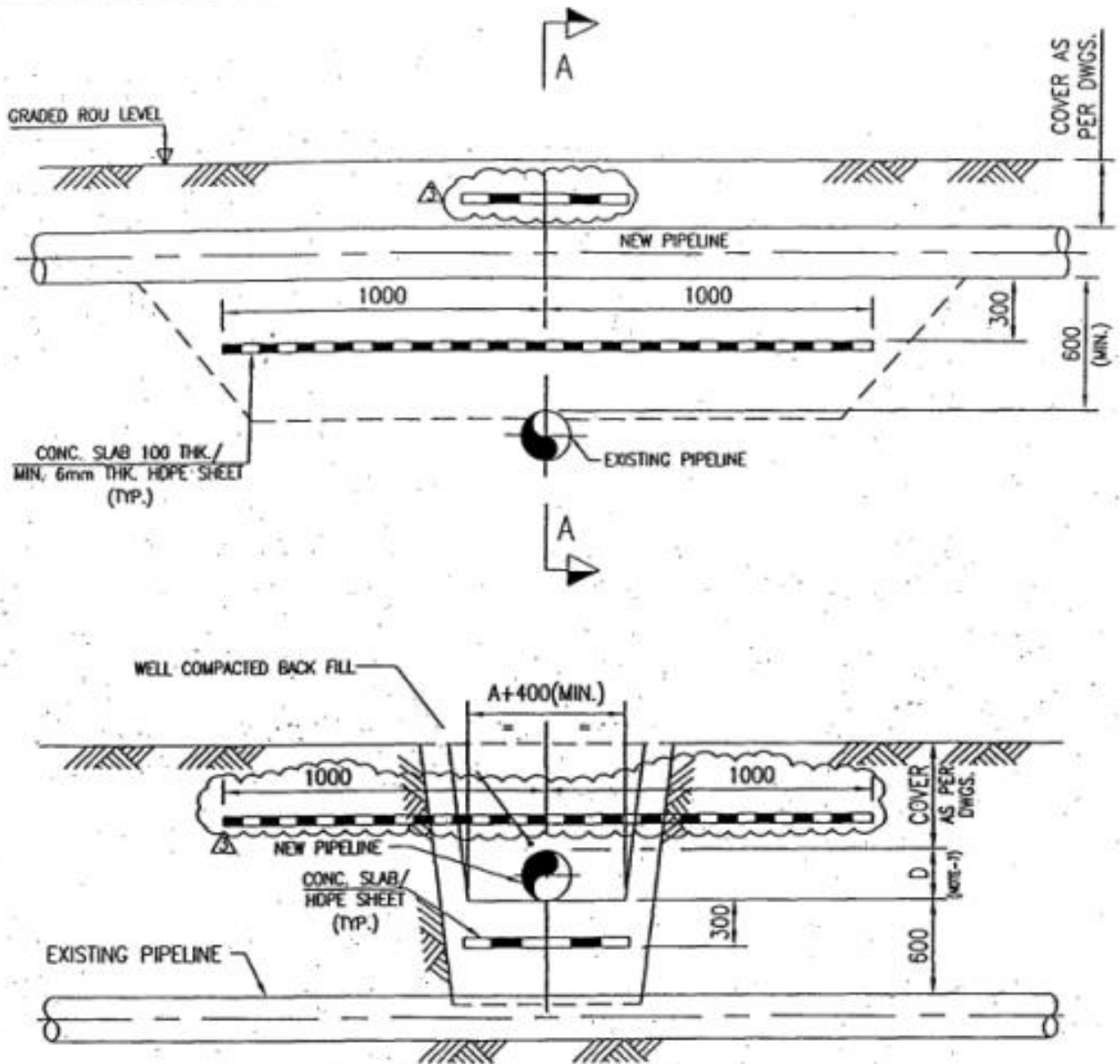

SECTION A-A

NOTES:-

1. A MODIFIED PIPELINE WARNING SIGN SHALL BE INSTALLED WHERE THE PIPELINE CROSSES AN EXISTING PIPELINE CARRYING HAZARDOUS FLUID.
2. CONCRETE SLAB PCC M15 AS PER IS 456 OR MIN. 6mm THK. HDPE SHEET SHALL BE PROVIDED.
3. CONC. SLAB NEED NOT TO BE PROVIDED BETWEEN AN EXISTING PIPELINE AND A NEW CASED PIPELINE.
4. SUITABLE CATHODIC PROTECTION BONDING SHALL BE PROVIDED BETWEEN CROSSING PIPELINES. IN SOME CASES THE NEW PIPELINE MAY REQUIRE ELECTRICAL ISOLATION. C.P. DETAILS ARE COVERED SEPARATELY.
5. ALL DIMENSIONS ARE IN MM UNLESS OTHERWISE STATED.
6. DIMENSION 'A' SHALL BE CALCULATED USING FORMULA $A=(D1+D2+...+Dn) + (n-1) \times 500$ WHERE D1, D2,.... Dn ARE THE DIAMETERS OF PIPELINES IN mm IN THE SAME TRENCH AND 'n' IS NO. OF PIPELINES IN SAME TRENCH.
7. DIMENSIONS 'D' SHALL BE THE LARGEST DIAMETER OF THE PIPELINES LAID IN SAME TRENCH.
8. TRENCH DIMENSIONS SHALL BE IN ACCORDANCE WITH RELEVANT STANDARDS/SPECIFICATIONS.
9. APPROVAL OF THE CROSSING SHALL BE OBTAINED FROM CONCERNED AUTHORITIES.

3	14.11.03	REVISED AS MARKED.	DM	<i>Deepak</i>	JM		V.V.A	
2	15.09.03	REVISED AS MARKED.	CHP	<i>Deepak</i>	BHP	BHP	V.V.A	V.V.A
1	21.05.02	REVISED AS MARKED.	DM	<i>Deepak</i>	KB	KB	V.V.A	V.V.A
0	21.11.01	APPROVED.	DM	<i>Deepak</i>	KB	KB	V.V.A	V.V.A
REV. NO.	DATE	SUBJECT OF REVISION	DRAWN	CHECKED	APPROVED			

EXISTING UNDERGROUND PIPE
CROSSING (TYPE-I)

DRAWING NO.

STD-19-022

PAGE NO.

1

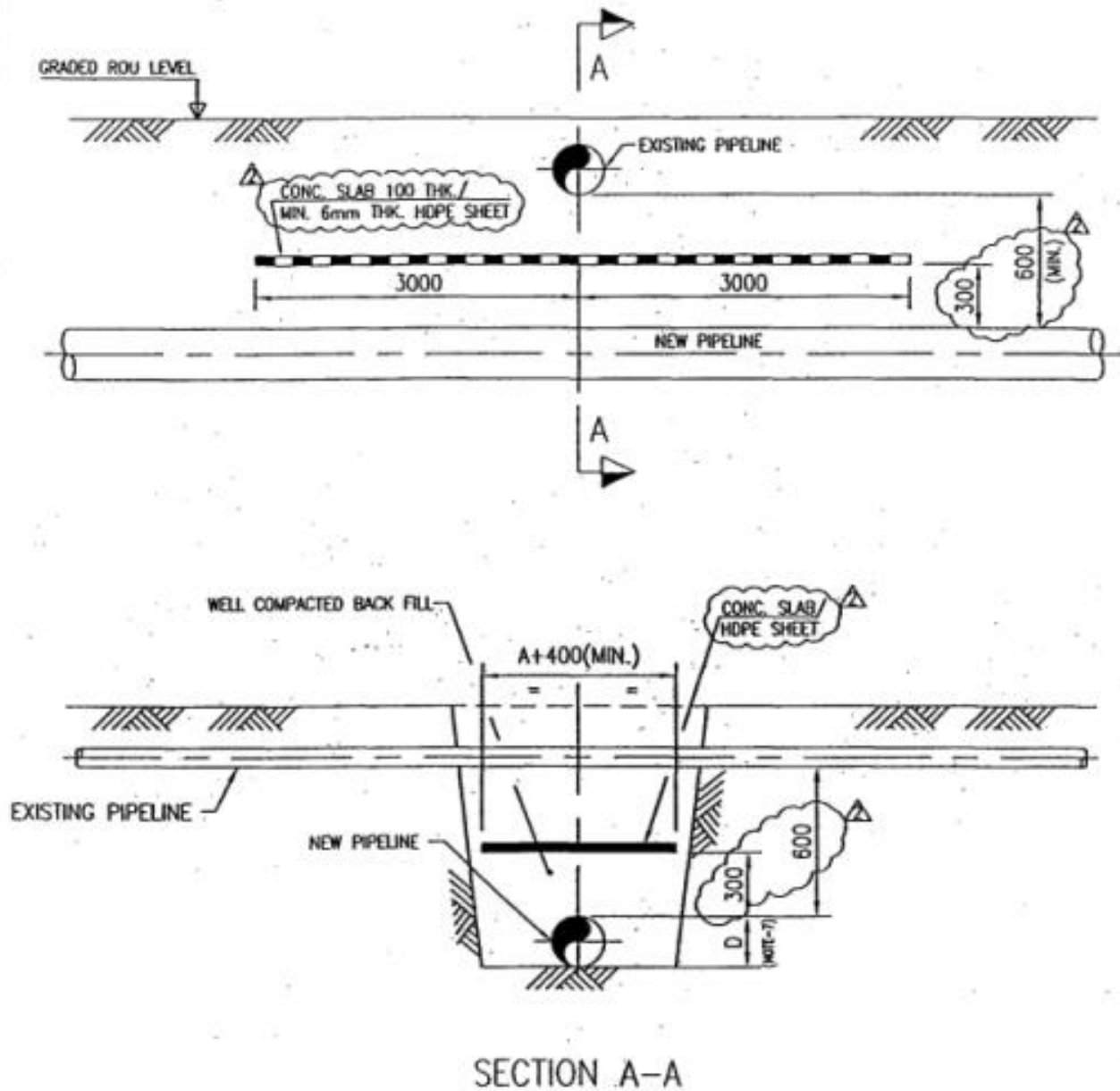

SECTION A-A

NOTES:-

1. A MODIFIED PIPELINE WARNING SIGN SHALL BE INSTALLED WHERE THE PIPELINE CROSSES AN EXISTING PIPELINE CARRYING HAZARDOUS FLUID.
2. CONCRETE SLAB PCC M15 AS PER IS 456 OR MIN. 6mm THK. HDPE SHEET SHALL BE PROVIDED.
3. CONC. SLAB NEED NOT BE PROVIDED BETWEEN AN EXISTING PIPELINE AND A NEW CASED PIPELINE.
4. SUITABLE CATHODIC PROTECTION BONDING SHALL BE PROVIDED BETWEEN CROSSING PIPELINES. IN SOME CASES THE NEW PIPELINE MAY REQUIRE ELECTRICAL ISOLATION.
5. ALL DIMENSIONS ARE IN MM UNLESS OTHERWISE STATED.
6. DIMENSION 'A' SHALL BE CALCULATED USING FORMULA $A=(D1+D2+....Dn) + (n-1) \times 500$ WHERE D1, D2,.... Dn ARE THE DIAMETERS OF PIPELINES IN mm IN THE SAME TRENCH AND 'n' IS NO. OF PIPELINES IN SAME TRENCH.
7. DIMENSIONS 'D' SHALL BE THE LARGEST DIAMETER OF THE PIPELINES LAID IN SAME TRENCH.
8. TRENCH DIMENSIONS SHALL BE IN ACCORDANCE WITH RELEVANT STANDARDS/SPECIFICATIONS.
9. APPROVAL OF THE CROSSING SHALL BE OBTAINED FROM CONCERNED AUTHORITIES.

2	15.09.03	REVISED AS MARKED. ⚠	CHP	Chetan	BHP		V.V.A	
1	21.05.02	REVISED AS MARKED. ⚠	DM	Deepak	KB	KB	V.V.A	V.V.A
0	21.11.01	APPROVED.	DM	Deepak	KB	KB	V.V.A	V.V.A
REV. NO.	DATE	SUBJECT OF REVISION	DRAWN		CHECKED		APPROVED	

PIPE LINE WARNING SIGN

DRAWING NO.

STD-19-015

PAGE NO.

1

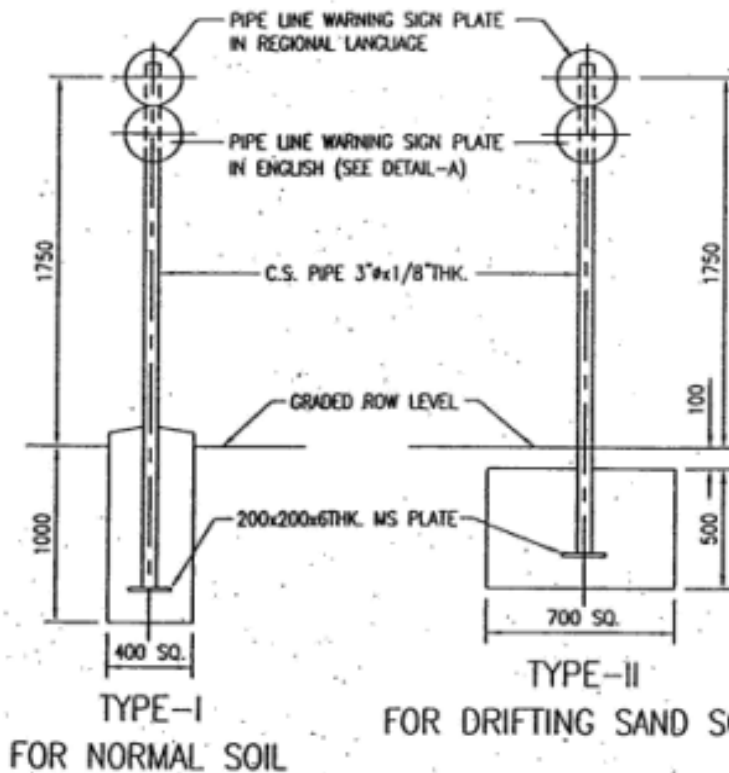

TYPE-II
FOR DRIFTING SAND SOIL

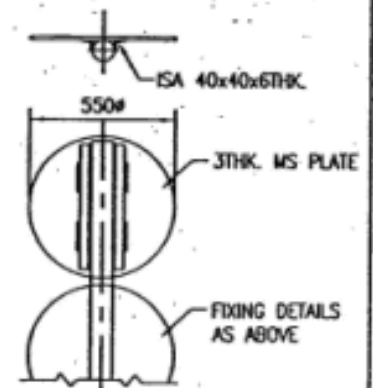
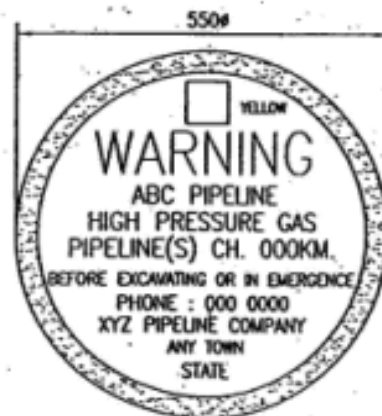
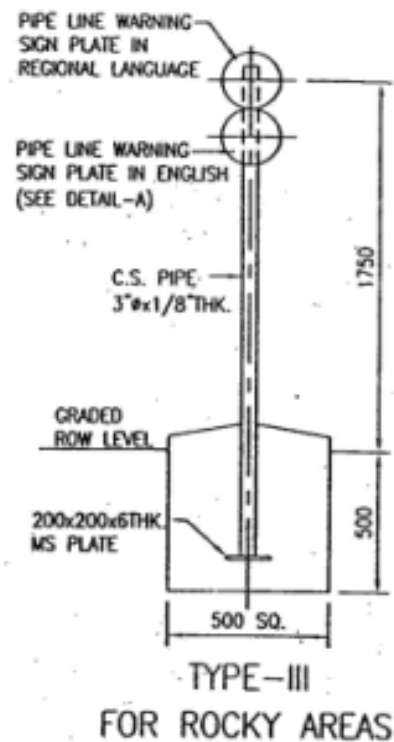

NOTES:-

1. ALL DIMENSIONS ARE IN MM UNLESS OTHERWISE STATED.
2. SCHEME OF PAINTING & COLOURING
 - (a) UNDERGROUND STEEL STRUCTURE (EXCEPT THAT EMBEDDED IN CONCRETE), : COAL TAR EPOXY MIN. 300 MICRON THK.
 - (b) OVERGROUND STEEL STRUCTURE : ONE COAT OF PRIMER & TWO COATS SPECIFIED COLOUR PAINT.
 - (c) COLOUR SCHEME FOR XYZ PIPELINE CO. MONOGRAM SHALL BE AS DIRECTED BY OWNER.
 - (d) ALL LETTERS EXCEPT WARNING SHALL BE PAINTED BLACK.
 - (e) POST SHALL BE PAINTED WITH 250 WIDE ALTERNATE BANDS OF BLACK AND WHITE PAINT.
 - (f) ALL OTHER ABOVEGROUND STEEL SHALL BE PAINTED YELLOW.
3. LOCATION
 - (a) THE PIPE LINE WARNING SIGN SHALL BE INSTALLED IN ACCORDANCE WITH CONTRACT REQUIREMENTS AND AS DIRECTED BY OWNER IT SHALL BE INSTALLED TO THE LEFT OF THE PIPE CENTER LINE, VIEWING IN THE DIRECTION OF FLOW AT 300MM FROM PIPELINE O.D. AND THE WARNING SIGN PLATE SHALL FACE THE UTILITY BEING CROSSED.
 - (b) THE WARNING SIGN PLATE MAY BE MOUNTED ON VENT PIPES OR KM POST WHERE EVER POSSIBLE.
4. THE FOUNDATION SHALL BE MADE OF CONCRETE M20.
5. SIGN PLATE IN REGIONAL LANGUAGE SHALL BE PREPARED BY CONTRACTOR ON SIMILAR LINES AND APPROVED BY THE OWNER.

0	21.11.01	APPROVED:	DM	.KB	V.V.A
REV. NO.	DATE	SUBJECT OF REVISION	DRAWN	CHECKED	APPROVED

	TYPICAL ROW BOUNDARY MARKER	DRAWING NO.	
		STD-19-017	
		PAGE NO.	1

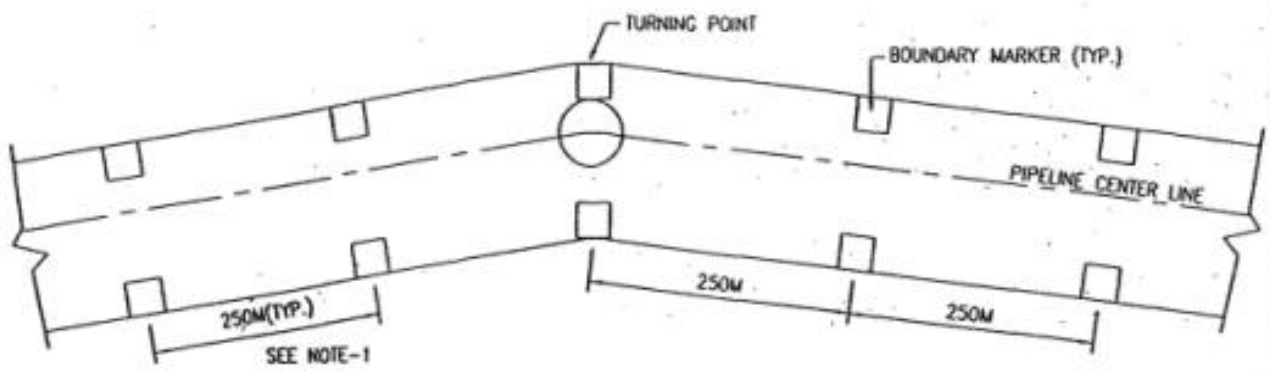

LOCATION PLAN OF BOUNDARY MARKER

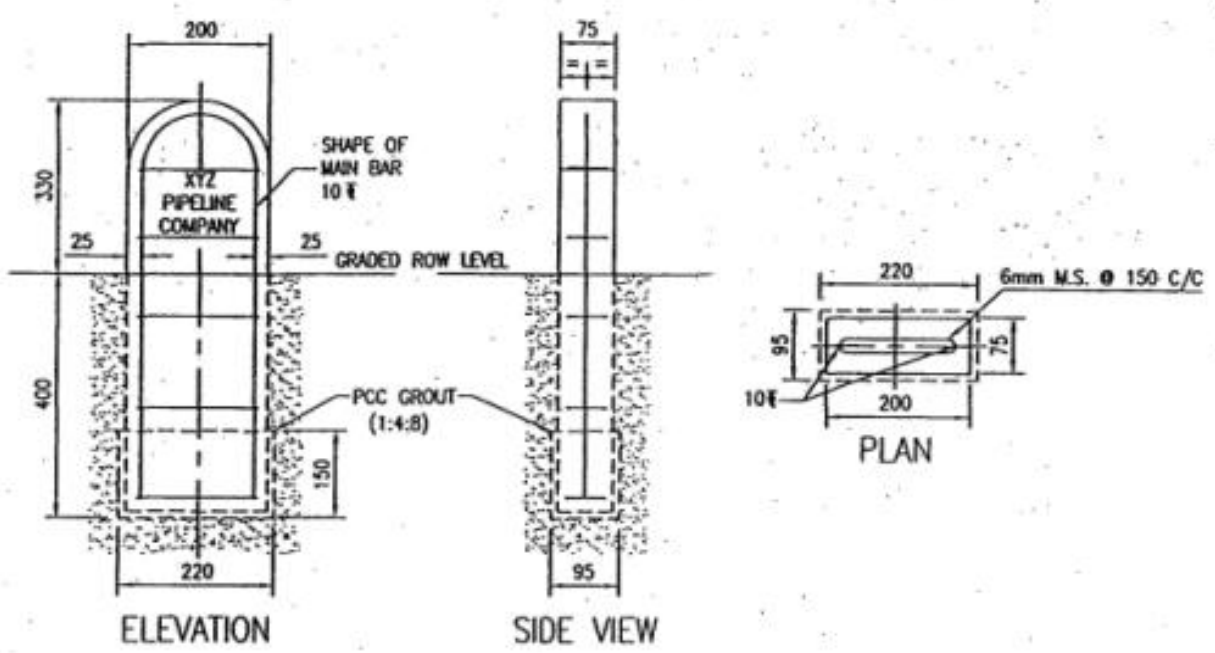

NOTES:-

1. ALL DIMENSIONS ARE IN MM UNLESS OTHERWISE STATED.
2. BOUNDARY MARKERS SHALL BE INSTALLED AT THE ROW LIMITS ON EITHER SIDE AT 250M CENTERS AND ALSO AT ALL TURNING POINTS AS PER SPECIFICATIONS AND AS DIRECTED BY OWNER. BOUNDARY MARKERS SHALL PREFERABLY BE PLACED ON FIELD BUNDOS/ UNCULTIVABLE AREAS.
3. ALL BOUNDARY MARKERS SHALL BE PRECAST AND INSCRIPTIONS SHALL BE ENGRAVED CENTRALLY IN THE MOULD ON THE FACE.
4. LETTERS SHALL BE 60 HIGH AND 5 DEEP.
5. INSCRIPTIONS SHALL FACE THE PIPE LINE.
6. CONCRETE FOR BOUNDARY MARKERS SHALL BE M20.
7. ABOVE GROUND PART OF BOUNDARY MARKERS SHALL BE PAINTED YELLOW WITH MIN. THREE COATS OF APPROVED QUALITY PAINT INSCRIPTIONS SHALL BE PAINTED BLACK.

0	21.11.01	APPROVED.	DM	KB	V.V.A.
REV. NO.	DATE	SUBJECT OF REVISION	DRAWN	CHECKED	APPROVED

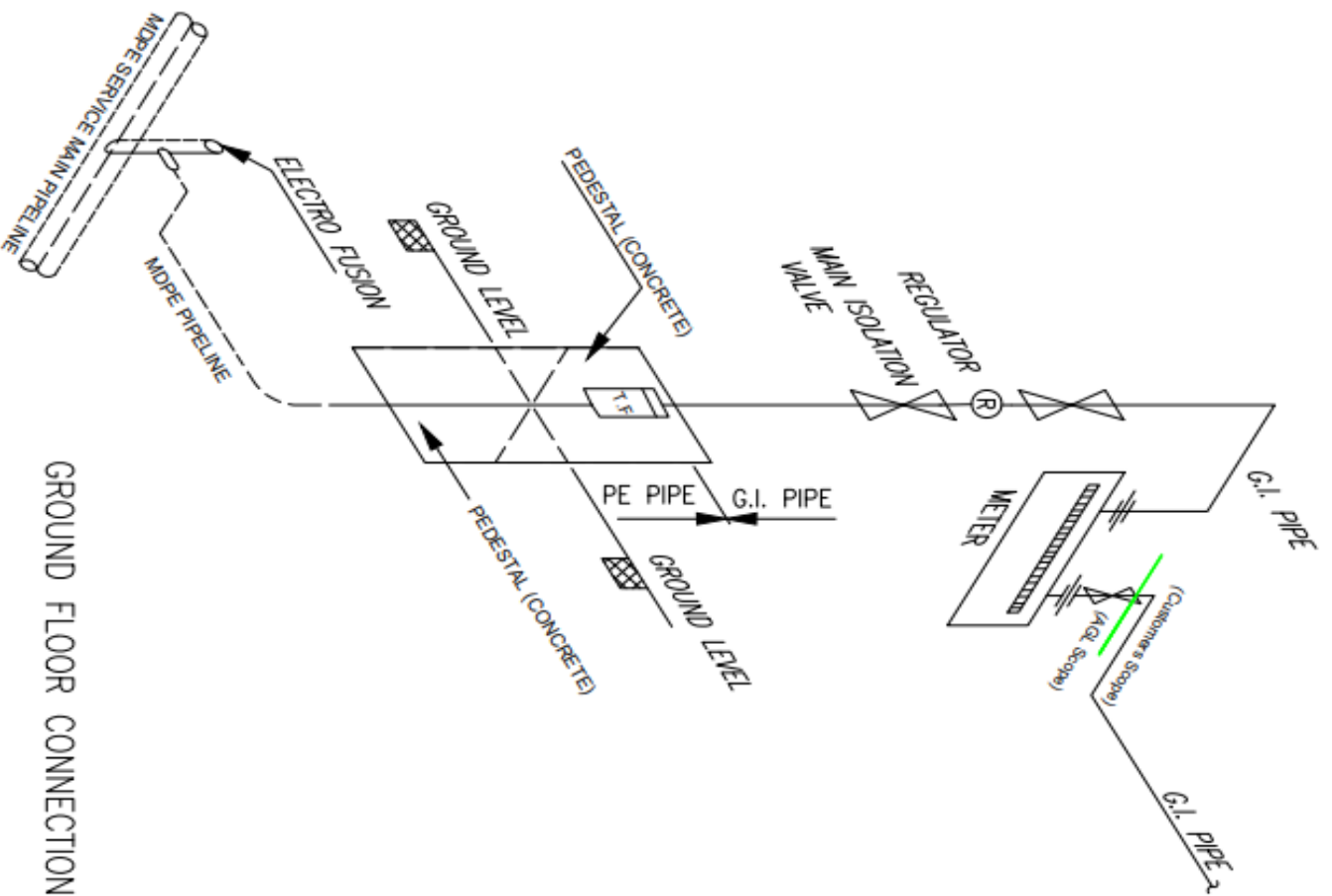

GROUND FLOOR CONNECTION

NOTE :-
 1) ALL DIMENSIONS ARE IN MM UNLESS OTHERWISE STATED!
 2) FOR DETAILS REFER PE PNG GUIDELINE

Aavantika Gas Limited

TYPICAL DRAWING FOR PIPELINE CONSTRUCTION			
PROJECT: TYPICAL DRAWING			
TITLE: TYPICAL COMMERCIAL CONNECTION			
SCALE	SHEET	DRAWING NO.	REV.
MTS	1 OF 1	AGL-TSPE-TYP	0

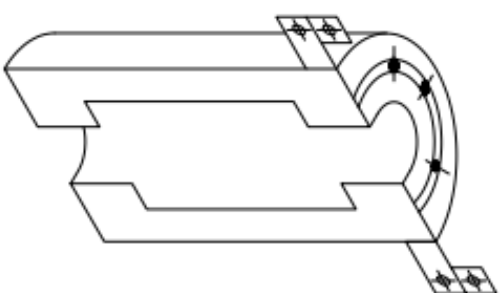
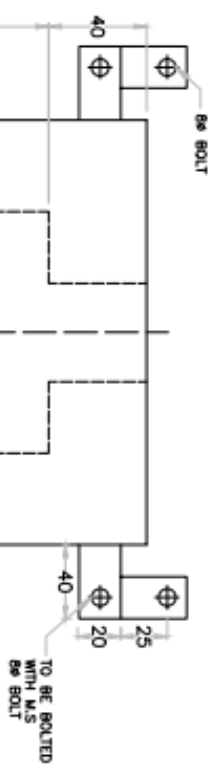
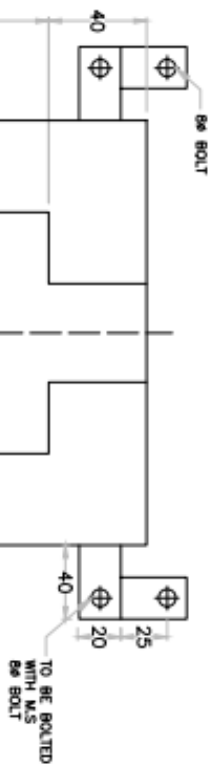
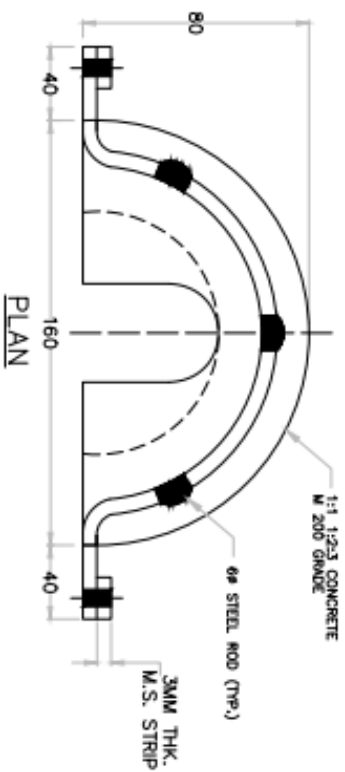

NOTE :-

1) ALL DIMENSIONS ARE IN MM UNLESS OTHERWISE STATED.

Avantika Gas Limited

TYPICAL DRAWING FOR PIPELINE CONSTRUCTION

PROJECT NAME: TYPICAL DRAWING

TITLE: TYPICAL DETAILS FOR RCC GUARD

SCALE	SHEET	DRAWING NO.	REV.
NTS	1 OF 1	AGL-TS/PE-TP/RCC GUARD-016	0

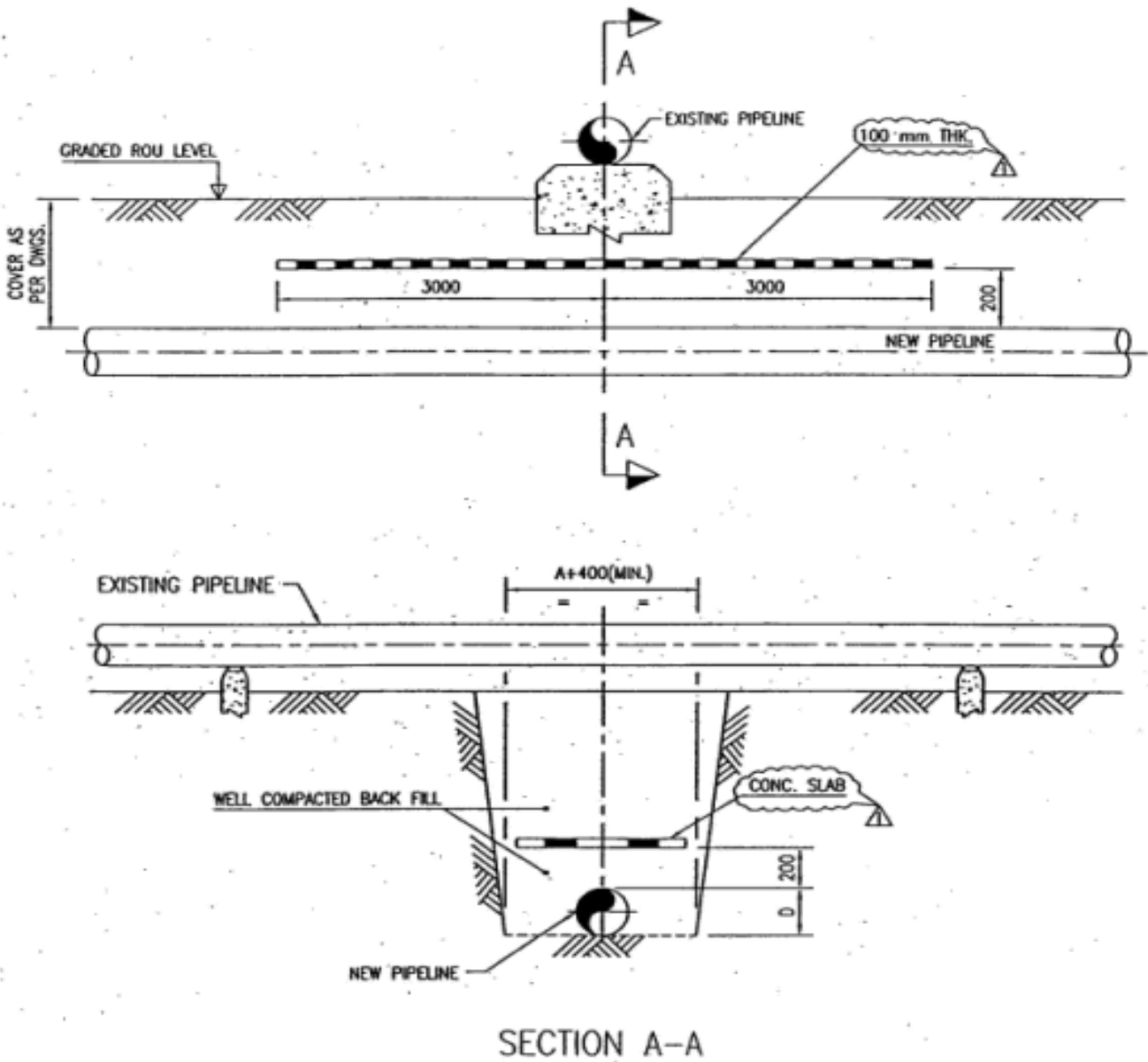

SECTION A-A

NOTES:-

1. A MODIFIED PIPELINE WARNING SIGN SHALL BE INSTALLED WHERE THE PIPELINE CROSSES AN EXISTING PIPELINE CARRYING HAZARDOUS FLUID.
2. DELETED.
3. CONC. SLAB NEED NOT TO BE PROVIDED BETWEEN AN EXISTING PIPELINE AND A NEW CASED PIPELINE.
4. ALL DIMENSIONS ARE IN MM UNLESS OTHERWISE STATED.
5. APPROVAL OF THE CROSSING SHALL BE OBTAINED FROM CONCERNED AUTHORITIES.
6. DIMENSION 'A' SHALL BE CALCULATED USING FORMULA $A=(D1+D2+...Dn) + (n-1) \times 500$ WHERE D1, D2, ..., Dn IS THE DIAMETER OF PIPELINES IN mm IN THE SAME TRENCH AND THERE ARE 'n' NO. OF PIPELINES IN SAME TRENCH.
7. DIMENSIONS 'D' SHALL BE THE LARGEST DIAMETER OF THE PIPELINES LAID IN SAME TRENCH.
8. TRENCH DIMENSIONS SHALL BE IN ACCORDANCE WITH RELEVANT STANDARDS / SPECIFICATIONS.

1	21.05.02	REVISED AS MARKED. ⚠	DM	<i>[Signature]</i>	KB		V.V.A
0	21.11.01	APPROVED.	DM	<i>[Signature]</i>	KB	KB	V.V.A V.V.A
REV. NO.	DATE	SUBJECT OF REVISION	DRAWN	CHECKED	APPROVED		

