



E-Tender No.: AGL/Head Office/Contract and Purchase/22/25-26/ET/22
[METERING SKIDS]
ANNUAL RATE CONTRACT (02 YEARS) FOR SUPPLY OF METERING SKIDS



AAVANTIKA GAS LIMITED

(A JOINT VENTURE COMPANY OF GAIL & HPCL)

CITY GAS DISTRIBUTION PROJECT IN
INDORE, UJJAIN, PITHAMPUR & GWALIOR

ANNUAL RATE CONTRACT
FOR
PROCUREMENT OF METERING SKIDS

E-Tender No.: AGL/Head Office/Contract and Purchase/22/25-
26/ET/22 [METERING SKIDS]

OPEN DOMESTIC COMPETITIVE BIDDING

ISSUE DATE: 25.02.2026

Date & Time for online submission duration of Technical Bid & Price Bid at MSTC Portal:

Important Dates

Pre-Bid Clarification Duration	26/02/2026 to 12/03/2026
Physical Pre-Bid Meeting at AGL HO, Indore	03/03/2026 (11:00 Hrs.)
Date of Start (Live) for Online Submission of Tender	16/03/2026 (12:00 Hrs.)
Last Date & Time of Submission of Tender	24/03/2026 up to 16:00 Hrs.
Date & Time of Opening of Un-Priced (Technical) Bid	24/03/2026 up to 16:30 Hrs.

BASIC INFORMATION OF TENDER	
e-Tender Number	AGL/Head Office/Contract and Purchase/22/25-26/ET/22 [METERING SKIDS] dated 25.02.2026
Mode of Tendering	ONLINE e-Procurement System through https://www.mstcecommerce.com/eproc/ of MSTC Ltd.
Title	Procurement of Metering Skids ANSI 150#
Description	Annual Rate Contract (02 Years) for procurement of 2", 3" & 4" Metering Skids ANSI 150# Single Filtration with By-Pass
Tender Type	Public
Bid Type	Two Bid
Date of NIT available to firms to download	25.02.2026
Online Pre-Bid Clarification Duration	Start Date & Time: 26.02.2026 at 10:00 Hrs.
	End Date & Time: 12.03.2026 up to 18:00 Hrs.
	<p>The e-procurement shall also have the event of online pre-bid meeting duration as detailed mentioned above. For Technical/Commercial clarification(s) (if any), they may bring to the attention of officials of AGL. The queries raised during online Pre-Bid meeting duration shall be replied on line. In the interest of bidder(s), they are also requested to go through the final technical specifications and other terms & conditions, based on the clarifications given during the pre-bid meeting duration and accordingly submit online tender.</p> <p>Query (if any) shall be clarified during online pre-bid meeting, only. After closing of online pre-bid meeting duration, no further queries shall be entertained.</p> <p>Based on the replied queries, Corrigendum may be issued on the MSTC website, which is to be digitally submitted as integral part of the bid.</p> <p>All entries in the tender should be entered in online mode without any ambiguity.</p>
Offline Pre-Bid meeting Date & Time	Bidders also have an option of attending a physical pre bid meeting at AGL, HO Indore Dated 03.03.2026 from 11:00 Hrs. to 12:00 Hrs.
Earnest Money Deposit (EMD) :	<p>EMD - Rs. 3.80 Lakhs in the form of DD or BG. Tender Fee: -Nil Account & other details (if required) are mentioned below: Bank details for BG/LC (SFMS) receiving through SFMS:</p> <p>Bank Name: ICICI Bank Limited Bank IFSC: ICIC0000041 Bank A/c No.: 004105013583 Bank Address: ICICI BANK LTD, MALAV PARISAR,4 CHOTI KHAJRANI, A.B. ROAD.INDORE 452008 (M.P), INDORE</p> <p>(Note: - For Participation in Tender, the Tender Fee has been waived off, however Tender processing charges of MSTC is applicable as per "Special Note towards Transaction fee" of MSTC mentioned in NIT MSTC instruction to bidders Sr. No. 2, Page no. 5 of Tender Document)</p> <p><u>Bidders registered with NSIC/MSME under its single point registration scheme are exempted from furnishing Bid Security. UDYAM / NSIC / MSME certificate (updated & valid as on due date of submission to be submitted) shall be duly attested by CHARTERED ACCOUNTANT (CA) AND NOTARY PUBLIC WITH LEGIBLE STAMP.</u></p> <p>NOTE: Bidder to upload the copy of EMD or UDYAM/NSIC/MSME Certificate along with the technical part, however copy of the same uploaded document is to be submitted in a separate envelope scribed with the Tender number, Tender Subject, Name of the bidder and Bid due date in physical form within 7 (Seven) days from the due date of submission of bid at the communication address: (PLEASE NOTE THAT CUTOUT SLIP TO BE PASTED OUTER OF THE EMD ENVELOPE WHICH IS ATTACHED AS PAGE No. 08)</p> <p>(Contract & Procurement Dept.) Aavantika Gas Limited 202-B, NRK Business Park, Vijay Nagar Square, Indore-452010 (M.P) Phone: 0731-4222520</p>



**E-Tender No.: AGL/Head Office/Contract and Purchase/22/25-26/ET/22
[METERING SKIDS]
ANNUAL RATE CONTRACT (02 YEARS) FOR SUPPLY OF METERING SKIDS**



Date & Time of Starting of e-tender for online submission of Technical Bid & Price Bid at https://www.mstcecommerce.com/eproc/	16.03.2026 at 12:00 Hrs.
Date of Closing of e-tender for submission of Technical Bid & Price Bid	24.03.2026 at 16:00 Hrs.
Date & time of opening of Un-Priced Bid/ Technical Bid Date of opening of Part II i.e. price bid shall be informed separately. [Under unforeseen circumstances, if the due dates (i.e. Date & time of opening of Part-I) fall on holiday, the same will be opened on the next full working day at the same time].	24.03.2026 at 16:30 Hrs.
Submission of Tender Document	Only digitally signed copy of all Tender documents will be accepted. Bids submitted in any other form will not be accepted and entertained by AGL and will not be considered for evaluation purpose.
Delay in Submission of online Tender Document	AGL will not responsible for any delay in submission of online tender documents for any reason, whatsoever.
Good Practices	<ul style="list-style-type: none"> • Bidders are advised to submit their online bids timely. Do not wait for last time and avoid last minute of submission. • Bidder has to submit copy of EMD or NSIC/MSME Certificate in physical form within seven (07) days from the due date of submission; however, Bidder shall try to TIMELY SEND THE COPY OF EMD or NSIC/MSME CERTIFICATE TO AGL OFFICE

NOTE:

- **BIDDERS SHALL ENSURE THAT ALL DIGITALLY SIGNED DOCUMENTS RELATED TO PRE-QUALIFICATION (TECHNICAL OR COMMERCIAL) ARE SUBMITTED AT THE FIRST INSTANCE ALONG WITH THE ORIGINAL BID.**
- **UPLOADED ATTESTED & NOTORIZED COPY OF EMD/NSIC/MSME CERTIFICATE TO BE SEND TO AGL OFFICE IN A SEPRATE ENVELOPE SCRIBED WITH THE TENDER NUMBER, TENDER SUBJECT, NAME OF THE BIDDER & BID DUE DATE WITHIN 7 (SEVEN) DAYS FROM THE DUE DATE & TIME OF SUBMISSION OF BID. PLEASE NOTE THAT CUTOUT SLIP TO BE PASTED OUTER OF THE EMD ENVELOPE. THE AGL RESERVES THE RIGHT TO ACCEPT OR REJECT ANY OR ALL THE PROPOSALS IN WHOLE OR PART WITHOUT ASSIGNING ANY REASONS.**
- **INITIAL STEP FOR ONLINE BIDDING THROUGH MSTC PORTAL IS THAT VENDORS HAVE TO GET REGISTERED IN MSTC PORTAL FOR PARTICIPATING IN ANY UPLOADED AGL E-TENDER. FOR MORE INFORMATION, VENDORS CAN DOWNLOAD VENDOR REGISTRATION GUIDE THROUGH MSTC Portal "<https://www.mstcecommerce.com/eproc/> > Vendor Login > Register > Registration Guide".**

KINDLY NOTE THAT ONLY ONLINE BID WILL BE CONSIDERED AGAINST THIS TENDER

**Website for Online bid Submission:
<https://www.mstcecommerce.com/eproc/>**



Prior uploading all the Techno-Commercial PDF Tender Documents on MSTC website please ensure that all the documents should be Digitally Signed.

Vendor to Sign (Digital) in the given below box area----->

1. PRE-BID MEETING & QUERIES

Online Pre-Bid queries duration shall be as schedule stated in page 1, Also bidder(s) or his official representative has an option to attend an offline pre-bid meeting which will take place as per scheduled date. Bidder(s) queries if any, must send your queries online through MSTC Portal prior to pre-bid meeting duration end date.

BID CLARIFICATION AFTER OPENING OF TECHNICAL BID

Important Note: Bidders are strictly advised to upload all the documents along with their bid itself by the due date and time. In the absence of requisite documents submitted along with their bid, AGL reserves the right to evaluate the bids as per the submitted documents only and reject the bid without making any reference to the Bidder.

For any queries/clarification after opening of Technical-Bid, AGL will send only online queries to bidder through MSTC Portal and Bidder has insured that he will reply the AGL queries online, through MSTC Portal only. No any queries/clarification/reply will be communicated / accepted through email.



E-Tender No.: AGL/Head Office/Contract and Purchase/22/25-26/ET/22
[METERING SKIDS]
ANNUAL RATE CONTRACT (02 YEARS) FOR SUPPLY OF METERING SKIDS



AAVANTIKA GAS LIMITED
(A JOINT VENTURE COMPANY OF GAIL & HPCL)

CITY GAS DISTRIBUTION PROJECT IN
 INDORE, UJJAIN, PITHAMPUR & INDORE & GWALIOR

NOTICE INVITING TENDER (NIT)

MSTC INSTRUCTIONS TO BIDDERS:

This is an e-Procurement event of **Aavantika Gas Limited**. The e-Procurement service provider is MSTC Ltd., 1st Floor, Tilhan Sangh Bhawan, 1 Arera Hills MPOILFED Building Bhopal-462004 (Madhya Pradesh).

1	<p>Requirement for Vendors: P.C. connected with Internet. Registration with MSTC Portal "https://www.mstcecommerce.com/eproc/" as vendor. Registration is free of cost. The Vendor should possess Class III signing & encryption type digital certificate. Vendors are to make their own arrangement for bidding from a P.C. connected with Internet. MSTC/AGL in no way responsible for this. (Bids will not be recorded without Digital Signature). In case of any clarification, please contact MSTC/AGL (well in advance before the schedule closing time of the e-Tender).</p> <p>CONTACT PERSON at MSTC LTD for Online Assistance:</p> <ol style="list-style-type: none"> 1) MSTC IVRS Helpdesk number: 07969066600 2) Centralized Helpdesk: 033-23400020, 033-23400021, 033-23400022 3) MSTC Bhopal Office numbers: 0755-2552241, 2593772, 2593775, 2593776; 4) Mr. Neeraj Mathur, Dy. Manager, Mob. 8871111473, Email: bplop4@mstcindia.in, mstcbpl@mstcindia.in, <p>CONTACT PERSON at Aavantika Gas Limited:</p> <ol style="list-style-type: none"> 1) Mr. Varendar Sharma, Ch Mngr: Mobile – 98889 25792 / Email: varendar.sharma@aglonline.net 2) Mr. Himanshu Shrivastava, Manger, Mobile – 9131099726 / Email: himanshu.s@aglonline.net 3) Mr. Anurag Singh, Engineer: Mobile – 86006 90470 / Email: anurag@aglonline.net 4) cp@aglonline.net 0731-4222520
2	<p>Special Note towards Transaction fee:</p> <p>The vendors shall pay the transaction fee using "Transaction Fee Payment" Link in the vendor login. The vendor shall have the facility of making the payment either through NEFT or Online Payment. On selecting NEFT, the vendor shall generate a challan by filling up a form. The vendor shall remit the transaction fee amount as per the details printed on the challan without making change in the same. On selecting Online Payment, the vendor shall have the provision of making payment using its Credit/ Debit Card/ Net Banking. Once the payment gets credited to MSTC's designated bank account, the transaction fee shall be auto authorized vendor to submit the bid.</p> <p>Transaction fee is non-refundable.</p> <p>A vendor will not have the access to online e-tender without making the payment towards transaction fee.</p> <p>NOTE: Bidders are advised to remit the transaction fee well in advance before the closing time of the event so as to give themselves sufficient time to submit the bid.</p>
3	<p>Vendors are instructed to use "My Document" link in "EVENT" menu to upload all scanned copies of documents viz. testimonials, registration certificates etc. in document library. Hard copies of bidding document will not be considered for evaluation.</p> <p>Multiple documents can be uploaded. Once documents are uploaded in the library, vendors can attach documents through Attach Document link for respective e-Tender.</p>
4	<ol style="list-style-type: none"> a) Technical Bid will be opened electronically on specified date and time as given in the NIT. Bidder(s) can witness electronic opening of bid. b) Price bid will be opened electronically of only those bidders(s) whose Technical Bid is found to be technically acceptable. Such bidder(s) will be intimated date of opening of Price bid, through valid email confirmed by them.
5	<p>SPECIAL NOTE:</p> <ol style="list-style-type: none"> a. Bidders are required to ensure that their registered email ID, provided is valid and updated at the stage of registration of vendor with MSTC. Bidders are also requested to ensure validity of their DSC (Digital Signature Certificate). b. Bidders are requested to see the web site once again before the due date of tender opening to ensure that they have not missed any corrigendum uploaded against the said tender after downloading the tender document. The responsibility of downloading the related corrigendum, if any, will be that of the downloading parties. c. Bidders are also requested to download vendor guide available in login under link "Download Guides" and study the same and post their queries, if any, to MSTC over e-mail well in advance. d. Bidders are requested to give sufficient time to bid in an organized manner and report any problem arisen to MSTC in advance & not in the closing stage.

6.0 AVAILABILITY OF TENDER DOCUMENT ON WEBSITE(S):

- 1) **AGL's Tender Website – <https://www.aglonline.net/e-tender/>**
- 2) **MSTC Tender Website – <https://www.mstcecommerce.com>**

Note - Bidders are requested to visit the website regularly to keep themselves updated.

Bid must be submitted only on <https://www.mstcecommerce.com/eproc/> Bid(s) received from bidders to whom tender/information regarding this Tender Document has been issued as well as offers received from the bidder(s) by downloading Tender Document from above mentioned website(s) shall be taken into consideration for evaluation & award provided that the Bidder is found responsive and subject to provisions contained in Instructions to Bidders.

7.0 All entries in the tender should be entered in online Technical & Commercial formats on the website of MSTC (e-procurement service provider) without any ambiguity.

8.0 Technical bid will be opened online on specified date and time as given in NIT.

9.0 Bidders are instructed to use **Upload Documents** link in **Document Library** to upload documents in document library. Multiple documents can be uploaded. **Maximum size of single document for uploading is 5 MB.**

Once documents are uploaded in the library, bidders can attach them through Attach Document link against the particular tender. Please note that if documents are not attached to any tender, the same cannot be downloaded by AGL and it will be deemed that vendor has not submitted the documents. For further assistance, follow instructions of vendor guide.

10.0 All notices and correspondence to the bidder(s) shall be sent by email only, till finalization of tender takes place by AGL as well as by MSTC. Hence, the bidders are required to ensure that email address provided by them is valid and updated with MSTC (i.e. service provider). Bidders are also requested to ensure validity of their DSC (Digital Signature Certificate).

11.0 (a) At any time prior to the deadline for submission of online tender, the AGL may for any reason, modify the Tender. Please note that there is no provision to take out list of parties downloading the RFP/ tender document from the web site mentioned in NIT. As such, bidders are requested to see the web site once again before the due date of opening to ensure that they have not missed any corrigendum uploaded against the said Tender after downloading the Tender document. The responsibility of downloading the related corrigendum, if any, will be of the bidder only.

(b) Intimation in respect of corrigendum to this NIT (if any) will be sent through email to tenderer(s) who have downloaded the documents from the website. Please see also website <https://www.mstcecommerce.com/eproc/> of MSTC Ltd. The AGL reserves the right to accept or reject any or all the proposals in whole or part without assigning any reasons.

12.0 E-tender cannot be accessed after the due date and time mentioned in NIT.

13.0 **Bidding in e-Tender**

- 1) Bidder to upload the copies of EMD/MSME/NSIC along with the technical part, however original copy of the same to be submitted in physical form within 7 (Seven) days from the due date of submission of bid. Refund of EMD in case of submission of DD will be made through e-payment or manual cheque (As per Tender terms).
- 2) The process involves Electronic Bidding for submission of Technical bid as well as Priced / Commercial bid.
- 3) Only those bidder(s) who have submitted the above fees can submit their Technical and Commercial bid through internet in MSTC website: www.mstcecommerce.com.
- 4) In all cases bidder should use their own ID and password along with Digital Signature at the time of submission of their bid.
- 5) During the entire e-tender process, the bidders will remain completely anonymous to one another and also to everybody else.



E-Tender No.: AGL/Head Office/Contract and Purchase/22/25-26/ET/22
[METERING SKIDS]
ANNUAL RATE CONTRACT (02 YEARS) FOR SUPPLY OF METERING SKIDS



- 6) The e-tender floor shall remain open from the pre-announced date & time till the date and time as mentioned above in Notice Inviting Tender.
 - 7) All electronic bids submitted, using valid Digital Signing Certificate, during the e-tender process shall be legally binding on the bidder. Any bid will be considered as the valid bid offered by that bidder and the acceptance of the same by AGL (Buyer) will form a binding contract between Buyer and the Bidder for execution of work. Such successful tenderer shall hereafter be called VENDOR.
 - 8) It is mandatory that all the bids are submitted with digital signature certificate otherwise the same will not be accepted by the system.**
 - 9) AGL reserves the right to cancel or reject or accept or withdraw or extend tender in full or part as the case may be without assigning any reason thereof.
 - 10) No deviation from the terms and conditions of the tender document is acceptable. Submission of bid in the e-tender floor by any bidder confirms his acceptance of terms and conditions for the tender.
 - 11) Unit of Measure (UOM) is indicated in the e-tender Floor. Rate to be quoted should be in Indian Rupees as per UOM indicated in the e-tender floor/ tender document.
- 14.0** During pre-qualification and evaluation of the e-tender, the AGL may, at its discretion, ask respondents for clarifications on their proposal. The respondents are required to respond within the time frame prescribed by the AGL



CUT-OUT SLIP

(Outer Envelope / EMD)

CLIENT : AGL, INDORE
PROJECT : CITY GAS DISTRIBUTION PROJECT
BID DOCUMENT NO. : **AGL/Head Office/Contract and Purchase/22/25-26/ET/22 [METERING SKIDS]**
WORK
DUE DATE & TIME : To,
C&P Department
Avantika Gas Limited,
Second Floor 202-B, NRK Business Park,
Vijay Nagar Square, AB Road, Indore-452010
Telephone: +91 (731) 4222520

FROM

NAME:

ADDRESS:



E-Tender No.: AGL/Head Office/Contract and Purchase/22/25-26/ET/22
[METERING SKIDS]
ANNUAL RATE CONTRACT (02 YEARS) FOR SUPPLY OF METERING SKIDS



COVERING LETTER FORMAT IN BIDDER'S LETTERHEAD

Bidder Ref No.

Date:

To,
Manager
Contracts and Procurement
Dept. Aavantika Gas Limited
Second Floor 202-B, NRK
Business Park, Vijay Nagar
Square, AB Road, Indore-452010
Tel- +91 (731) 4222520

e-Tender No. AGL/Head Office/Contract and Purchase/22/25-26/ET/22 [METERING SKIDS] dated 25.02.2026

Letter of Bid Submission against subject e-Tender for Procurement of 2", 3" & 4" Metering Skids ANSI 150# Single Filtration Bypass on ARC basis for Two (02) years.

Dear Sir,

With reference to above mentioned subject, please find enclosed herewith our Bid on behalf of "**BIDDER'S COMPANY NAME**", along with Tender documents and below enclosures as required for the Bid;

1. (Document Name e.g. EMD details, Bidder's General Information) 2.
3.
4.
5.
6.
7.

Thanks and Regards,

Submitted By :- "BIDDERS COMPANY NAME"
Authorized :-
Person :-
Designation :-

Authorized Signatory

S. No.	Section	Particulars
1.	Section – I	Invitation for Bid (IFB)
2.	Section – II	Instructions to Bidders (ITB)
3.	SECTION – III	Payment Terms
4.	SECTION – IV	Technical Specification
5.	SECTION – V	General Condition of Contract - Goods (GCC-Goods)
6.	SECTION – VI	Forms and Formats
7.	SECTION – VII	Packaging, Marking and Shipping
8.	SECTION – VIII	Schedule of Rates (SOR)



E-Tender No.: AGL/Head Office/Contract and Purchase/22/25-26/ET/22
[METERING SKIDS]
ANNUAL RATE CONTRACT (02 YEARS) FOR SUPPLY OF METERING SKIDS



SECTION I
INVITATION FOR BIDS (IFB)



**E-Tender No.: AGL/Head Office/Contract and Purchase/22/25-26/ET/22
[METERING SKIDS]
ANNUAL RATE CONTRACT (02 YEARS) FOR SUPPLY OF METERING SKIDS**



Aavantika Gas Limited (AGL) (hereinafter referred as Owner), is supplying Piped Natural Gas (PNG) to domestic, commercial and Industrial consumers and Compressed Natural Gas (CNG) to automobiles in Indore, Ujjain and Gwalior cities of Madhya Pradesh. AGL invites digitally signed (encrypted) bids under single stage Two Bid system from eligible bidders for the supply of 2", 3" & 4" Metering Skids ANSI 150# Single filtration by-pass on ARC basis for 2 Years.

This shall be a Unit rate contract valid for a period of Two (02) years. The quantities mentioned in the Schedule of Rates (SOR) are indicative and for inviting unit rates for the items and for evaluation purpose only. However, the procurement will be done based on the actual requirement by placing separate Purchase Orders (PO) each time during the validity of the Rate Contract.

- 1.0 PROJECT : CITY GAS DISTRIBUTION PROJECT FOR INDORE, UJJAIN, PITHAMPUR & GWALIOR**
- 2.0 ITEM & QUANTITY REQUIRED : MENTIONED IN SCHEDULE OF RATES (SOR)**
- 3.0 SCOPE OF WORK : SUPPLY OF METERING SKIDS SINGLE FILTERATION BYPASS**
- CONTRACT PERIOD : ARC VALID FOR TWO YEARS FROM DATE OF AWARD**
- 4.0 DELIVERY PERIOD : REQUIRED DELIVERY FROM THE DATE OF ISSUANCE OF EACH PURCHASE ORDER (PO) SHALL BE AS FOLLOW:**

Schedule	Item Description	Quantity In Nos.	Delivery period from the date of Purchase Order (PO)
LOT-1	2" Metering Skid ANSI 150# Single Filtration with Bypass	63	08 Weeks
LOT-2	3" Metering Skid ANSI 150# Single Filtration with Bypass	3	
LOT-3	4" Metering Skid ANSI 150# Single Filtration with Bypass	2	

- Delivery shall be on FOT site basis.
- The Metering Skids shall be delivered at AGL Store / Site at Indore, Pithampur, Ujjain & Gwalior locations in M.P.

- 5.0 BID VALIDITY : 4 MONTHS FROM BID DUE DATE.**
- 6.0 BID SECURITY / EMD : Rs 3.80 Lakh in form of DD/Bank Guarantee**

The bid security shall be in the form of Demand Draft or Bank Guarantee in favour of Aavantika Gas Limited, Indore (India), valid for 2 months in excess of bid validity period i.e. for 06 months in the prescribed format (Form F-4) of the bid document.

Bidders registered with UDYAM/NSIC/MSME under its single point registration scheme are exempted from furnishing Bid Security. UDYAM / NSIC / MSME certificate (updated & valid as on due date of submission to be submitted) shall be duly attested by CHARTERED ACCOUNTANT (CA) AND NOTARY PUBLIC WITH LEGIBLE STAMP.

NOTE:

Bidder to upload the copy of EMD or NSIC/MSME Certificate along with the technical part, however copy of the same uploaded document is to be submitted in a separate envelope scribed with the Tender number, Tender Subject, Name of the bidder and Bid due date in physical form within 7 (Seven) days from the due date of submission of bid at the



E-Tender No.: AGL/Head Office/Contract and Purchase/22/25-26/ET/22
[METERING SKIDS]
ANNUAL RATE CONTRACT (02 YEARS) FOR SUPPLY OF METERING SKIDS



communication address:

Contract & Procurement Dept.
Aavantika Gas Limited
202-B, NRK Business Park,
Vijay Nagar Square, Indore-452010 (M.P)
Phone: 0731-4222520

PLEASE NOTE THAT CUTOUT SLIP (ATTACHED IN THIS TNDER DOCUMENT-PAGE NO. 8) TO BE PASTED OUTER OF THE EMD ENVELOPE.

7.0 BID DOCUMENT FEE (NON-REFUNDABLE & NON-TRANSFERABLE): Nil

8.0 The Bid Document calls for offers on single point “Sole Bidder” basis. Bidders are advised not to submit offers in “Consortium” or “Joint Bid”. Joint bid referred herein is an offer, which seeks order to be placed on more than one party / co-bidder.

9.0 The prices once quoted shall not be changed whether resulting or arising out of any subsequent technical / commercial clarifications sought regarding the bid and even if any deviation or exclusion may be specifically stated in the bid.

10.0 Bidder is advised to quote strictly as per scope & terms and conditions of bid document and not to stipulate any deviation / exceptions.

11.0 Purchaser reserves the right to accept or reject any or all bids received at its absolute discretion without assigning any reason, whatsoever.

12.0 Bid document is non-transferable. Bids received from bidders in whose name Bid Document has been issued shall only be considered. Bidder must submit the Bid Document Fee in their name. Bid Document Fee will be submitted by Bidders as per Clause 7.0 above.

13.0 Bidder shall ensure that Bid Security having a validity of 2 months beyond the offer validity, i.e. validity of 6 months from the bid due date, must accompany the offer in the format made available in the Bid Document. Offer, if unaccompanied with Bid Security, shall be rejected.

14.0 Bids complete in all respects should reach on or before the BID DUE DATE AND TIME. Fax/ /Telegraphic/ E-Mail bids shall be rejected.

15.0 AGL shall not be responsible for cost incurred in preparation and delivery of bids.

16.0 This is **ZERO DEVIATION** bid document. The bids shall be evaluated as received without any Reference to the bidder. The Bids not meeting the Technical Specifications mentioned in the Technical Part (Vol. II of II) of this Tender Document will be rejected.

17.0 AGL reserves the right to reject any or all the bids received at its discretion without assigning any reason whatsoever.

18.0 BID EVALUATION CRITERIA- TECHNICAL:

Bidder shall have manufactured and supplied below tabulated Metering Skids in Single Order within Five (05) years reckoned from bid due date.

SN	Item Description – NATURAL GAS SKID	Minimum Supplied Quantity
1	Single/Dual Filtration Skid with or without By-Pass, ANSI150# (Minimum Size – 2” & Minimum Rating – 150#)	17 Nos



E-Tender No.: AGL/Head Office/Contract and Purchase/22/25-26/ET/22
[METERING SKIDS]
ANNUAL RATE CONTRACT (02 YEARS) FOR SUPPLY OF METERING SKIDS



*** Multiple Orders issued under Single Tender are considered on cumulative basis as SINGLE CONTRACT

In support of above qualifying criteria, the bidder has to submit following documents:

- Order(s) of Award duly issued by Client CGD Company
- A) Supply Completion Certificate (Full or Partial Completion)
OR
B) Inspection Release Note duly issued by reputed Inspection Agency
OR
C) Tax invoice, Proof of Payment, Payment advise

Above specified (A,B,C) documents should have cross reference to Order(s) of Award

19.0 BID EVALUATION CRITERIA - COMMERCIAL:

- **Turnover:** The contractor should have achieved a minimum turnover of ₹ 47.50 Lakhs in any one of the last 3 (three) audited financial year
- **Working Capital:** The contractor should have achieved a minimum working of ₹ 9.50 Lakhs in the last audited balance sheet
- **Net Worth:**
Net worth must be positive as per last audited financial statement.
Contractors must submit copy of financial statements including Balance Sheet and Profit & Loss account statement certified by Chartered Accountant for last three audited financial years in support of the above.
- **Declaration Letter/Certificate for line of credit (If the bidder's working capital is inadequate)**
 - i) Declaration Letter/Certificate for line of credit due to short fall of working capital shall be from single bank only. Letters from multiple banks shall not be applicable. However, banking syndicate will also be acceptable wherein a group of banks can jointly provide line of credit to the bidder.
 - ii) The bank shall be required to issue the letter from declaration/certificate of line of credit on their letter head along with the contact details of the issuing authority like email id, contact number etc. The Format for certificate from Bank for Line of Credit is attached as FORM-3C.

AUTHENTICATION OF DOCUMENTS TO BE SUBMITTED IN SUPPORT OF BEC:

Technical Criteria of Bid Evaluation Criteria (BEC):

All documents in support of Technical Criteria of Bid Evaluation Criteria (BEC) to be furnished by the bidders shall necessarily be duly certified / attested by Chartered Engineer and notary public with legible stamp.
Documents duly issued by AGL can be submitted without any certification / attestation / authentication.

Financial Criteria of Bid Evaluation Criteria (BEC):

Bidder shall submit "Details of financial capability of bidder" in prescribed format 'F-03' duly signed and stamped by a chartered accountant.
All documents in support of Bid Capacity to be furnished by the bidders shall necessarily be duly certified by the Chartered Accountant.
Practicing Chartered Accountants shall generate Unique Document Identification Number (UDIN) for all certificates issued by them as per provisions of tender document.
However, UDIN may not be required for documents being attested by Chartered Accountants in terms of provisions of tender document.

All documents in support of BEC should be scanned and uploaded in the e tendering portal. In absence of requisite documents, AGL reserves the right to reject the bid without making any reference to bidders.

20.0 EVALUATION AND COMPARISON OF BIDS:

- a) Evaluation shall be done on overall lowest cost basis.
- b) If quoted amount of two or more L-1 ranked bidders are same, then items will be awarded to that L-1 bidder whose **Net Worth** as per Last Audited Balance Sheet will be higher.



E-Tender No.: AGL/Head Office/Contract and Purchase/22/25-26/ET/22
[METERING SKIDS]
ANNUAL RATE CONTRACT (02 YEARS) FOR SUPPLY OF METERING SKIDS



SECTION - II

INSTRUCTIONS TO BIDDERS

A. Introduction

1 SCOPE

- 1.1 The Purchaser invites sealed bids for the entire work as specified in the Bid documents (Hereafter referred to as the Work).
- 1.2 The Bid document specifies the contractor scope of work, terms & conditions.
- 1.3 All terms, conditions and specifications of the Bid document shall be construed as applicable in general, unless specifically indicated to the contrary.
- 1.4 Bidders shall quote in the manner as specified in the Bid document. Purchaser reserves the right to evaluate and accept bids at their sole discretion. The provisions of this clause shall supersede any contrary provisions expressly stated or implied anywhere else in the Bid document.

2 ELIGIBILITY OF BIDDERS.

- 2.1 Bidders shall as part of their bid, submit a written Power of Attorney authorizing the signatory of the bid to bind the bidder.
- 2.2 Bidders should not be associated, or have been associated in the past, directly or indirectly, with a firm or any of its affiliates which have been engaged by the Purchaser to provide consultancy services for the preparation of the design, specifications, and other documents to be used for carrying out similar Works under this Invitation for Bids.
- 2.3 The Bidders shall not be under a declaration of ineligibility for corrupt and fraudulent practices issued by the Purchaser in accordance with ITB.

3 ONE BID PER BIDDER

- 3.1 A bidder shall submit only one bid in the same bidding process. A bidder who submits or participates in more than one bid will be disqualified.
- 3.2 Alternative bids are not acceptable.

4 COST OF BIDDING

- 4.1 The bidder shall bear all costs incurred & associated with the preparation and submission of the bid, and Purchaser will in no case be responsible or liable for this cost, regardless of the conduct or outcome of the bidding process.

5 NON-TRANSFERABILITY OF THE BID DOCUMENTS

- 5.1 Bid Documents are non-transferable. The party to whom the Bid documents are issued may only furnish the bid. The bid received from any party other than to whom the Bid documents are issued shall be rejected immaterial of fact of any relationship between party to whom Bid documents are issued and party, who furnished the bid.

6 SITE VISIT (as applicable)

- 6.1 The bidder is advised to visit and examine the site of works and its surroundings and obtain for himself on his own responsibility, all information that may be necessary for preparing of the bid and entering into contract. The cost of visiting the site shall be at bidder's own expenses.
- 6.2 The bidder or any of its personnel or agents will be granted permission by the Purchaser to enter upon its premises and land for the purpose of such visits, but only upon the



E-Tender No.: AGL/Head Office/Contract and Purchase/22/25-26/ET/22
[METERING SKIDS]
ANNUAL RATE CONTRACT (02 YEARS) FOR SUPPLY OF METERING SKIDS



Express condition that the bidder, its personnel, and agents will release and indemnify the Purchaser and its personnel and agents from and against all liabilities in respect thereof, and will be responsible for death or personal injury, loss of or damage to property, and any loss, damage, costs, and expenses incurred as a result of the inspection.

B. BID DOCUMENTS

7 CONTENTS OF BID DOCUMENTS

- 7.1 The Bid Documents are those stated below and should be read in conjunction with any corrigendum issued in accordance with clause 9.2 of Instruction to Bidder (ITB):
- 7.1.1 Invitation For Bid (IFB)
 - 7.1.2 Instruction To Bidders (ITB)
 - 7.1.3 Payment Terms
 - 7.1.4 Technical Specification
 - 7.1.5 General Conditions of Contract-Goods (GCC-Goods)
 - 7.1.6 Forms and Formats
 - 7.1.7 Packaging and Marking
 - 7.1.8 Schedule of Rates (SOR)
- 7.2 The bidder is expected to examine all instructions, forms, terms, specifications and drawings in the bid documents. The Bid Documents together with all its attachment thereto, shall be considered to be read understood and accepted by the bidder. Failure to furnish all information required by the Bid documents or submission of a bid not substantially responsive to the Bid documents in every respect will be at bidder's risk and may result in the rejection of the Bid.

8 CLARIFICATION ON BID DOCUMENTS

- 8.1 A prospective bidder requiring any clarification of the Bid Documents may notify Purchaser in writing or by fax at the address mentioned in the Invitation for Bid (IFB). Purchaser will respond in writing to any request for clarification of the Bid documents which it receives after issue of bid documents. Written copies of Purchaser's response (including an explanation of the query, if required, but without identifying the source of the query) will be sent to all prospective bidders who have received the Bid documents.

9 AMENDMENT OF BID DOCUMENTS

- 9.1 At any time prior to the bid due date, Purchaser may, for any reason, whether at its own initiative or in response to a clarification requested by a prospective bidder, modify the Bid documents, by issuing corrigendum.
- 9.2 Any corrigendum thus issued shall be part of the Bid documents pursuant to ITB Clause-17 and shall be notified in writing by fax / post to all prospective bidders, who have received the Bid documents. Prospective bidders shall promptly acknowledge receipt of each corrigendum by fax/ post to the Purchaser.
- 9.3 The Purchaser may, at its discretion, extend the bid due date in order to allow prospective bidders, a reasonable time to furnish their most competitive bid taking into account the amendments issued.

- 9.4 In order to allow reasonable time to respond to bidders queries, bidders must submit their queries, if any, at least seven (07) days before the bid submission due date. Queries received after this period will not be considered.

C. PREPARATION OF BID DOCUMENT

10 LANGUAGE OF BID

- 10.1 The bid prepared by the bidder as well as all correspondence/ drawings and documents relating to the bid exchanged by bidder shall be written in English language, provided that any printed literature furnished by the bidder may be written in another language so long as accompanied by an ENGLISH translation, in which case, for the purpose of interpretation of the bid, the ENGLISH translation shall govern.

11 DOCUMENTS COMPRISING THE BID

- 11.1 The bid prepared by the bidder shall comprise of the following components:

11.1.1 Techno-Commercial Un priced - Bid (PART-I).

- A. Covering letter with bidder's offer number.
- B. Bidder's General Details / information as per format F-1.
- C. Bid Security (EMD) as per format F- 4. **(Bids received without EMD shall be rejected)**
- D. Copies of various documents as required as per F-2, F-3, F-3A & 3B, F-5, F-8, F-10, F-12 and F-13
- E. NO Deviation Confirmation as per F- 6 on bidder's letter head.
- F. Copy of Un-Priced SOR marked "QUOTED" against the items quoted.
- G. Documentary evidence established in accordance with ITB that the bidder is eligible to bid and is qualified to perform the contract if its bid is accepted.
- H. Addendum / Corrigendum, if any, to the Tender.
- I. Power of Attorney/Authorization Letter authorizing the signatory of the bid.

11.1.2 "Online Price Bid".

Bidder has to quote rate in the Price Format duly available on Bidding floor during submission of Price against the SOR on MSTC Portal.

12 BID PRICES

- 12.1 The Prices should be quoted in INR only.
- 12.2 The Bidder shall indicate in the appropriate Price Schedule, the unit prices (where applicable) and total price of the services / works it proposes to execute under the contract. If quoted in separate typed sheets and any variation in item description, unit or quantity is noticed, the bid is liable to be rejected.
- 12.3 Bid quoted for part scope is liable to be rejected.
- 12.4 Prices quoted by the bidder, shall remain firm, fixed and valid until completion of the contract and will not be subjected to any variation, except statutory variation (as specified in Bid document.)
- 12.5 All corrections and alterations in the entries shall be signed in full by the bidder with date.



E-Tender No.: AGL/Head Office/Contract and Purchase/22/25-26/ET/22
[METERING SKIDS]
ANNUAL RATE CONTRACT (02 YEARS) FOR SUPPLY OF METERING SKIDS



No erasures or over-writings are permissible.

- 12.6 Bidder shall quote the all-inclusive prices as per scope of work and SOR, taking into consideration all applicable taxes, duties, overheads, provision of safety gadgets to their personnel, transportation, conveyance, trainings, recruitments, communication charges, cost for providing tools & tackles, equipment's, machineries, minimum spares, etc. and nothing extra shall be payable by the Purchaser.
- 13 PERIOD OF VALIDITY OF BIDS**
- 13.1 The bid shall remain valid for 4 months from the bid due date. Purchaser may reject a bid which is valid for a shorter period being non-responsive.
- 13.2 In exceptional circumstances, prior to expiry of the original bid validity period, the Purchaser may request that the bidder extend the period of bid validity for a specified additional period. The requests and the responses thereto shall be made in writing (by fax/ post/ e-mail). A bidder can refuse the request without forfeiture of his bid security. A bidder agreeing to the request will not be required or permitted to modify his bid, but will be required to extend the validity of its bid security for the period of the extension and in accordance with ITB clause 14 in all respects.
- 14 BID SECURITY**
- 14.1 Pursuant to IFB Clause No. 6, the bidder shall furnish, as part of his bid, bid security in the amount specified in the Invitation for Bids.
- 14.2 The bid security is required to protect the Purchaser against the risk of bidder's conduct which would warrant the security's forfeiture, pursuant to ITB Clause- 14.7
- 14.3 The bid security will be in Indian Rupees and shall be in the form of Demand Draft / Banker's Cheque is to be drawn in favor of **Aavantika Gas Ltd**, payable at Indore or in the form of Bank Guarantee as per format F-4 enclosed in the Bid Document.
- 14.4 Any bid not secured in accordance with ITB Clause 24 and ITB Clause 14.3 may be rejected by the Purchaser as non-responsive.
- 14.5 Unsuccessful bidder's bid security will be discharged/ returned, as promptly as possible but not later than 30 days after the expiration of the period of bid validity prescribed by the Purchaser, pursuant to ITB Clause-13.
- 14.6 The successful bidder's bid security will be discharged upon the bidder's accepting the Order, pursuant to ITB Clause- 34 and furnishing the Contract Performance Guarantee pursuant to ITB Clause- 35.
- 14.7 The bid security may be forfeited:**
- 14.7.1 If a bidder withdraws his bid during the period of bid validity.
- 14.7.2 In the case of a successful bidder, if the bidder fails:
- To accept the Purchase Order in accordance with ITB Clause- 34 or
 - To furnish Performance Guarantee in accordance with ITB Clause-35
 - To accept correction of errors pursuant to ITB Clause- 26
- 14.8 Bid Security must indicate the Bid Document number and the item for which the bidder is quoting. This is essential for proper co-relation at a later date. The Bid Security in the form of Bank Guarantee shall be as per the format provided in the Bid Document.
- 14.9 The Indian / Domestic firms registered with NSIC/MSME, under its single point registration scheme are exempted from furnishing Bid Security and Tender fees. NSIC / MSME certificate submitted shall be duly attested by CHARTERED ACCOUNTANT (CA) AND NOTARY PUBLIC WITH LEGIBLE STAMP.

15 FORMAT AND SIGNING OF BID

- 15.1 The bidder shall prepare the document comprising the bid as per clause 11 of ITB.
- 15.2 The bid shall be typed or written in indelible ink and shall be signed by the person or persons duly authorized to sign on behalf of the bidder. The name and position held by each person signing must be typed or printed below the signature. All pages of the bid except any catalogues / literatures shall be signed and sealed by the person or persons signing the bid.
- 15.3 The bid shall contain no alterations, omissions or additions, unless such corrections are signed & sealed by the person or persons signing the bid.

16 ZERO DEVIATION

- 16.1 Bidder to note that this is a zero deviation Tender. AGL will appreciate submission of offer based on the terms and conditions in the enclosed General Conditions of Contract (GCC), Special Conditions of Contract (SCC), Instructions to Bidder (ITB), Scope of work, technical specifications etc. to avoid delay in seeking clarifications on technical/commercial aspects of the offer. Bids with any deviation to the bid conditions shall be liable for rejection.

D. SUBMISSION OF BIDS

17 SEALING AND MARKING OF BIDS (NOT APPLICABLE)

- 17.1 Bid shall be submitted in the following manner in separate sealed envelopes duly super scribed as below:
Envelope - I – Techno-commercial / Un-priced bid
Envelope - II- Priced Bid “Not to be opened with Un-Priced Bid”
Envelope – III – Tender Fees / MSME / NSIC / UDYAM
- 17.2 All three envelopes containing EMD/MSME/NSIC & Bid Documents, Price Bids and Tender Fees shall further be sealed in one Master (outer) envelope super - scribing Name of Project, Tender Document Number and shall be addressed to the Purchaser at the address given in IFB.
- 17.3 Each envelop shall indicate name and address of the bidder to enable the bid to be returned unopened, if warranted.
- 17.4 If the outer envelope is not sealed and marked as above, the Purchaser will assume no responsibility for the misplacement or premature opening of the bid and its consequential rejection. The Purchaser recommends submission of Bids in – person and will assume no responsibility for any delay / damage to the bids received by Post / Courier.

18 DEADLINES FOR SUBMISSION OF BID

- 18.1 The Bid must be received by Purchaser (AGL) at the address as specified in IFB but not later than the time and date as specified in IFB.
- 18.2 The Purchaser may, in exceptional circumstances and at its discretion, on giving reasonable notice by fax or any written communication to all prospective bidders who have been issued the bid document extend the deadline for the submission of bids in which case all rights and obligations of the Purchaser and bidders, previously subject to the original deadline will thereafter be subject to deadline as extended.

19 LATE BIDS

19.1 Any bid received by the Purchaser after the deadline for submission of bid pursuant to clause no. 18 of ITB will be declared "Late" and rejected and may be returned unopened to the bidder at the sole discretion of the Purchaser.

20 MODIFICATION AND WITHDRAWAL OF BIDS

- 20.1 The bidder may modify or withdraw its bid after the bid submission, but, before the due date of submission provided that written notice of the modification, including substitution or withdrawal of the bid, is received by the Purchaser prior to the deadline prescribed for submission of bids.
- 20.2 The bidder's modification or withdrawal notice shall be prepared, sealed, marked and delivered in accordance with the Bid document, with the outer envelopes additionally marked "modification" or "withdrawal" as appropriate. A withdrawal notice may also be sent by fax/post, but followed by signed confirmation copy, post marked not later than the deadline for submission of bids.
- 20.3 No bid shall be modified after the deadline for submission of bid.
- 20.4 No bid shall be allowed to be withdrawn in the interval between the deadline for submission of bids and the expiration of the period of bid validity specified by the bidder on the bid form. Withdrawal of a bid during this interval shall result in the bidder's forfeiture of its bid security, pursuant to clause 14.7 of ITB.

E. BID OPENING AND EVALUATION

21 BID OPENING

- 21.1 The Purchaser will open all bids in the presence of Bidders' representatives who choose to attend, at the time, on the date and place (as specified in IFB). The Bidders' representatives, who are present, shall sign a register evidencing their attendance, if so required by the Purchaser.
- 21.2 The Bidder's names, bid modifications or withdrawals, and the presence or absence of requisite Bid Security (EMD) and such other details as the Purchaser, at its discretion, may consider appropriate, will be announced at the opening. No bid shall be rejected at bid opening, except for late bids.
- 21.3 Bids (and modifications sent pursuant to ITB Clause 30) that are not opened and read out at bid opening shall not be considered further for evaluation, irrespective of the circumstances. Bidder's specific attention is drawn to this stipulation to enable the representative of the Bidder at the bid opening time to bring out to the attention for the Purchaser any documents pertaining to its bid is not being acknowledged and relevant portions read out.
- 21.4 The Purchaser will prepare a bid opening statement to be signed by all representatives present during bid opening.

22 CLARIFICATION OF BID

- 22.1 During evaluation of the bids, the Purchaser may, at its discretion, ask the Bidder for a clarification of its bid. The request for clarification and the response shall be in writing, and no change in the prices or substance of the bid shall be sought, offered, or permitted.

23 CONTACTING THE PURCHASER

- 23.1 From the time of the bid opening to the time of the award, if any bidder wishes to contact the Purchaser for any matter relating to the bid it should do so in writing.
- 23.2 Any effort by a bidder to influence the Purchaser in any manner in respect of bid evaluation or award will result in the rejection of that bid.

24 PRELIMINARY EXAMINATION OF BIDS

24.1 Techno-Commercial Bid Evaluation

24.1.1 The Purchaser will examine the bids to determine whether they are complete, whether required securities have been furnished, whether the documents have been properly signed and whether the bids are generally in order.

24.1.2 Prior to the detailed evaluation, the Purchaser will determine whether each bid is of acceptable quality, is generally complete and is responsive to the Bid Documents. For the purpose of this determination, a responsive bid is one, which confirms to all the terms, conditions and specification of the Bid document, without deviations, objections, conditionality or reservations.

24.1.3 No deviation, whatsoever, is permitted in the Bid Documents and the price bids of those bidders, whose technical and commercial bids contain any exception to the conditions and stipulations of the Bid Documents may not be opened.

24.1.4 The Purchaser's determination of bid responsiveness is to be based on the contents of the bid itself without recourse to extrinsic evidence. If a bid is non-responsive, it may be rejected by the Purchaser.

24.1.5 The Purchaser will carry out a detailed evaluation of the bids previously determined to be responsive in order to determine whether the technical aspects are in accordance with the requirements set forth in the Bid documents. In order to reach such a determination, the Purchaser will examine and compare the technical aspects of the bids on the basis of the information supplied by the bidders, taking into account the following factors:

24.1.5.1 Overall completeness and compliance with the Technical Specifications, quality functions and operations of any process control concept included in the bid. The bid that does not meet minimum acceptable standard of completeness, consistency and detail will be rejected as non-responsive.

24.1.5.2 Any other relevant factor, if any that the Purchaser deems necessary or prudent to be taken into consideration.

24.1.5.3 Requisite forms contain all necessary information stipulated in the Bid Document.

25 REJECTION CRITERIA

25.1 Minor unconformities may be neglected and/or bidders may be required to rectify such minor unconformities.

25.2 The provisions of the following clauses of the Bid document must be adhered to, failing which the bid shall be considered as non-responsive and shall be summarily rejected:

25.2.1 Bid Security (EMD/MSME/NSIC) i.e. non-submission, shorter Value (EMD) or Bid Security (EMD) not complying with the specified requirements.

25.2.2 Submission of Contract Performance Bank Guarantee as per tender.

25.2.3 Period of validity of bid.

25.2.4 Firm & fixed Prices throughout execution of work

25.2.5 Offer for complete scope of work

25.2.6 Warranty and guarantee for work executed/ defect liability

25.2.7 Resolution of Dispute/ Arbitration clause.

25.2.8 Payment terms.

25.2.9 Validity of Contract.

25.2.10 Prices as per Schedule of Rates.

25.2.11 Price reduction schedule provisions.

25.2.12 Penalty provisions

25.3 **If any Vendor is adjudged as POOR Performer by AGL in preceding 12 Months from Tender bid due date, the bid submitted by such Vendor will NOT be considered.**

26 OPENING OF PRICE BID

26.1 The Bidder whose bid is found substantially responsive shall be invited to attend the opening of price bid. Such bidders may be required to attend the price bid opening at a short notice. The place, date and time of price bid opening will be informed to all such Bidders. The Bidders' representatives who are present shall sign a register evidencing their attendance.

26.2 The bid prices and discounts, if any stated in the price schedules will be announced during price bid opening.

27 ARITHMETIC CORRECTIONS

27.1 The bids will be checked for any arithmetical errors as follows if any, will be rectified on the following basis:

27.1.1 If there is a discrepancy between the unit price and the total price that is obtained by multiplying the unit price and quantity, the unit price shall prevail, and the total price shall be corrected;

27.1.2 If there is a discrepancy between words and figures, the amount in words will prevail;

27.2 If the bidder does not accept the correction of errors, its bid will be rejected and the bid security will be forfeited.

28 EVALUATION AND COMPARISON OF BIDS: Refer Serial No. 22 of IFB

29 POST-QUALIFICATION

29.1 In the absence of pre-qualification, the Purchaser will determine to its satisfaction whether the Bidder that is selected as having submitted the lowest evaluated responsive bid is qualified to perform the contract satisfactorily, in accordance with the criteria listed in ITB.

29.2 The determination will take into account the Bidder's financial, technical, and production Capabilities. It will be based upon an examination of the documentary evidence of the Bidder's qualifications submitted by the Bidder, as well as such other information as the Purchaser deems necessary and appropriate.

29.3 An affirmative determination will be a prerequisite for award of the contract to the Bidder. A negative determination will result in rejection of the Bidder's bid, in which event the Purchaser will proceed to the next lowest evaluated bid to make a similar determination of that Bidder's capabilities to perform satisfactorily.

F. AWARD

30 AWARD CRITERIA

30.1 Subject to ITB Clause 21 to 29 of section E, the Purchaser will place the order on the successful bidder whose bid has been determined to be substantially responsive and has been determined to be the lowest evaluated bid, provided further that the Bidder is determined to be qualified to perform the order satisfactorily. The Award of work shall be done in accordance with Clause No. 24 and 25 of IFB of this Document.

31 PURCHASER'S RIGHT TO VARY QUANTITIES



E-Tender No.: AGL/Head Office/Contract and Purchase/22/25-26/ET/22
[METERING SKIDS]
ANNUAL RATE CONTRACT (02 YEARS) FOR SUPPLY OF METERING SKIDS



31.1 Purchaser reserves the right to increase or decrease the quantities specified in the Schedule of Rates, without any change in unit price or other terms and conditions.

31.2 Bidder shall note that the quantities mentioned against each activity in Schedule of Rates are tentative only and subject to change based on actual requirement. The unit rates quoted by the bidders shall remain fixed and firm, no price adjustment shall be allowed after bid submission.

32 PURCHASER'S RIGHT TO ACCEPT ANY BID AND TO REJECT ANY OR ALL BIDS

32.1 Purchaser reserves the right to accept or reject any bid, and to annul the bidding process and reject all bids, at any time prior to award of contract, without thereby incurring any liability to the affected bidder or bidders or any obligations to inform the affected bidder or bidders the reason for the Purchaser's action.

33 NOTIFICATION OF AWARD / FAX OF INTENT

33.1 Prior to the expiration of period of bid validity, the Purchaser will notify the successful bidder in writing by fax or e-mail to be confirmed in writing that his bid has been accepted.

33.2 The date of Fax of Intent for notification of Award will constitute effective date.

33.3 Upon the successful bidder's furnishing of Contract Performance Bank Guarantee (CPBG), pursuant to ITB Clause 35, the Purchaser will promptly notify each unsuccessful bidder and will discharge the bid security of such bidders.

34 ACCEPTANCE OF PURCHASE ORDER

34.1 Purchaser will issue the Purchase Order to the successful bidder on receipt of acceptance of FOI, within 10 days of award of work, bidder shall sign all pages and return the acceptance copy of the Purchase Order to the Purchaser.

35 CONTRACT PERFORMANCE BANK GUARANTEE

35.1 Within Fifteen (15) days from the date of award, the successful bidder shall furnish the performance guarantee in accordance with Special Conditions of Contract in the form provided in the Bid documents.

35.2 The Contract Performance Bank Guarantee shall be for an amount as defined in Special Conditions of Contract and General Conditions of Contract (GCC) towards faithful performance of the contractual obligations. This bank guarantee shall be valid for a period of 3 months beyond the expiry of the contract, including the defect liability period.

35.3 Failure of the successful bidder to comply with the requirements of this clause shall constitute sufficient ground for the annulment of the award and forfeiture of the bid security.

36 CORRUPT AND FRAUDULENT PRACTICES

36.1 The Purchaser requires that Bidders observe the highest standard of ethics during the execution of Contract. In pursuance of this policy, the Purchaser defines, for the purposes of this provision, the terms set forth below as follows:

- i) "Corrupt Practice" means the offering, giving, receiving, or soliciting of anything of value to influence the action of public official in contract execution; and
- ii) "Fraudulent Practice" means a misrepresentation of facts in order to influence the execution of a Contract to the detriment of the Purchaser, and includes collusive practice amongst bidders (prior to or after bid submission) designed to establish bid prices at artificial non-competitive levels and to deprive the Purchaser of the benefits of free and open competition;



E-Tender No.: AGL/Head Office/Contract and Purchase/22/25-26/ET/22
[METERING SKIDS]
ANNUAL RATE CONTRACT (02 YEARS) FOR SUPPLY OF METERING SKIDS



36.2 Purchaser will reject a proposal for award, if it determines that the bidder recommended for award is engaged in corrupt or fraudulent practices in competing for the award in question;

36.3 Purchaser will declare a firm ineligible, either indefinitely or for a stated period of time, if at any time the Purchaser determines that the firm has engaged in corrupt or fraudulent practices in competing for or in executing a contract.

37 INCOME TAX LIABILITY

37.1 The bidder shall bear all Income Tax liability, both corporate as well as for his personnel.

38 EMPLOYEE PROVIDENT FUND (EPF) (As Applicable)

38.1 Bidders have to furnish the proof of existing Employee Provident Fund details.

39 GENERAL

39.1 Any failure on the part of the Purchaser at any time to enforce the strict observances of the performance of any of the term(s) and condition(s) or rights, shall not effect or deprive the Purchaser to exercise the same at any later date.

39.2 The work will be supervised by Purchaser's Engineer-In-Charge or his representative and the Contractor has to strictly adhere to his instructions.

39.3 During the tenancy of this contract, Purchaser can increase and/or decrease the quantity of the work/ service (s) required. The quantity of work / service (s) shown in the Schedule of rates is tentative.

39.4 The delivery period shall be reckoned from the date of DO.

39.5 The agreed rates shall remain firm & fixed till the expiry of contract and the contractor shall not be entitled to any inflation, escalation or revision (statutory or otherwise) or any right to claim, whatsoever by way of representation, explanation, statement or alleged representation or an outstanding or promise given or alleged to have been given by any employee of the Purchaser or due to contractor's own ignorance or on account of the difficulties or hardships faced by him. The rates quoted shall be all-inclusive of applicable taxes/ duties and shall remain firm till expiry/entire tenancy of this contract. It is agreed that the bidder has inspected the sites and assessed the nature and the extent of the work including the conditions prevalent under which the work is to be carried out.



E-Tender No.: AGL/Head Office/Contract and Purchase/22/25-26/ET/22
[METERING SKIDS]
ANNUAL RATE CONTRACT (02 YEARS) FOR SUPPLY OF METERING SKIDS



40.0 ELIGIBILITY CRITERIA IN CASE BID IS SUBMITTED ON THE BASIS OF TECHNICAL EXPERIENCE OF FOREIGN BASED ANOTHER COMPANY (SUPPORTING COMPANY) WHICH HOLDS MORE THAN FIFTY PERCENT OF THE PAID-UP SHARE CAPITAL OF THE BIDDER COMPANY OR VICE VERSA

Offers of those bidders (not under Consortium arrangement) who themselves do not meet the technical experience criteria as stipulated in BEC and are quoting based on the experience of foreign based another company (supporting company) can also be considered. In such case the supporting company should hold more than fifty percent of the paid up share capital of the bidding company or vice versa.

However, the supporting company should on its own meet the technical experience as stipulated in the BEC and should not rely on any other company or through any other agreement like technical collaboration agreement.

In that case as the bidding company is dependent upon the technical experience of another company with a view to ensure your commitment and involvement of the companies involved for successful execution of the contract, the participating bidder should enclose the following agreement/ guarantees/ undertakings along with the techno-commercial bid.

1. An agreement (as per format enclosed at format F-1 attached as Section-X) between the bidder and the supporting company.
2. Guarantee (as per format enclosed at format F-2 attached as Section-X) by the supporting company to Aavantika Gas Limited for fulfilling the obligation under the Agreement.
3. Undertaking by supporting company to provide a performance bank guarantee (as per format and instructions enclosed at format F-3 attached as Section-X) equivalent to 50% of the value of the PBG which is to be submitted by the bidding company, in case of being the successful bidder.

In case where foreign based supporting company does not have permanent establishment in India as per Indian Income Tax Act, the bidding company can furnish performance bank guarantee for an amount, which is sum of PBG amount to be submitted by the bidder and additional PBG amount required to be submitted by the supporting company subject to the condition that supporting company have 100% paid up equity share capital of the bidder either directly or through intermediate subsidiaries or vice versa.

In such case bidding company shall furnish an undertaking that their foreign based supporting company is not having any permanent establishment in India in terms of Income Tax Act of India.

4. Undertaking from the supporting company to the effect that in addition to invoking the PBG submitted by the bidding company, the PBG provided by supporting company shall be invoked by Aavantika Gas Limited due to non-performance of the bidding company.

Note: In case supporting company fails to submit Bank Guarantee as per (iii) above, EMD/SD submitted by the bidder shall be forfeited.

41. VENDOR EVALUATION PROCEDURE

1.0 PROCEDURE FOR EVALUATION FOR PERFORMANCE OF VENDORS/SUPPLIERS/CONTRACTORS/CONSULTANTS

2.1 GENERAL

A system for evaluation of Vendors/Suppliers/Contractors/Consultants and their performance is a key process and important to support an effective purchasing & contracting function of an organization.

Performance of all participating Vendors /contractors /consultants need to be closely monitored to ensure timely receipt of supplies from a vendor, completion of an assignment by a consultant or complete execution of order by a contractor within scheduled completion period. For timely execution of project and meeting the operation & maintenance requirement of Operating Plant / Location, it is necessary to monitor the execution of order or contract right from the award stage to completion stage and take corrective measures in time.

2.2 OBJECTIVE

The objective of evaluation of performance aims to recognize, and develop reliable Vendors/Suppliers/ Contractors/ Consultant so that they consistently meet or exceed expectations and requirements.

The purpose of this is to put in place a system to monitor performance of Vendors/Suppliers/ Contractors / Consultants associated with AGL in Project and O&M so as to ensure timely completion of various project, timely receipt of supplies including completion of works & services for operation and maintenance of Operating Plant / Location and quality standards in all respects.

2.3 METHODOLOGY

- i) Preparation of Performance Rating Data Sheet
Performance rating data sheet for each and every Vendor/Supplier/Contractor/Consultant for all orders/Contracts with a value of Rs 07 Lakhs and above is recommended to be drawn up. Further, Performance rating data sheet for orders/contracts of Vendor/Supplier/Contractor/Consultant who are on watch list/holiday list/banning list shall be prepared irrespective of order/contract value. These data sheets are to be separately prepared for orders/contracts related to Projects and O&M within 30 days after execution of Order/Contract. Format, Parameters, Process, responsibility for preparation of Performance Rating Data sheet are separately mentioned.
In case of non-performance, these data sheets are to be prepared, as and when need arises.
- ii) Measurement of Performance
Based on the parameters defined in Data Sheet, Performance of concerned Vendor/Supplier/Contractor/Consultant would be computed and graded accordingly. The measurement of the performance of the Party would be its ability to achieve the minimum scoring of 60% points in the given parameters.
- iii) Initiation of Measures:
Depending upon the Grading of Performance, corrective measures would be initiated by taking up the matter with concerned Vendor/Supplier/Contractor/Consultant. Response of Vendor/Supplier/Contractor/Consultant would be considered before deciding further course of action.
- iv) Implementation of Corrective Measures:
Based on the response of Vendor/Supplier/Contractor/Consultant pertaining to ongoing or completed orders/contracts, concerned Authority as specified in PO/WO would take approval from Competent Authority and recommend for continuation or discontinuation of such party from the business of AGL.

- v) Orders/contracts placed on Proprietary/OEM basis for O&M will be evaluated and, if required, corrective action will be taken for improvement in future.

Note: All departments other than Projects like O&M, HSE, HR, F&A, Marketing etc. will be covered under definition of O&M.

2.4 EXCLUSIONS:

The following would be excluded from the scope of evaluation of performance of Vendor/Supplier/Contractor/Consultant:

- i) Orders/Contracts below the value of Rs 07 Lakhs if Vendor/Supplier/Contractor/Consultant is not on watch list/holiday list/banning list.
- ii) Orders for Miscellaneous/Administrative items/Non stock Non valuated items.

However, concerned Engineer-in-Charge/OICs will continue to monitor such cases so as to minimize the impact on Projects/O&M due to non-performance of Vendor/Supplier/Contractor/Consultant in all such cases.

2.5 PROCESS OF EVALUATION OF PERFORMANCE OF VENDORS/SUPPLIERS/CONTRACTOR/CONSULTANTS

2.5.1 FOR PROJECTS:

- i) Evaluation of performance of Vendors/Suppliers/Contractors/Consultants in case of PROJECTS shall be done within 30 days of Commissioning of any Project / Completion of Contract.
- ii) On commissioning of any Project, EIC (Engineer-in-charge)/ Project-in-charge shall prepare a Performance Rating Data Sheet (Format enclosed) for all Orders and Contracts excluding cases under Para 2.4.
- iii) Depending upon the Performance Rating, following action need to be initiated by Engineer-in-charge/Project-in-charge:

Sr. No.	Performance rating	Action
1	POOR	Seek explanation for Poor performance
2	FAIR	Seek explanation for Fair performance
3	GOOD	Letter to the concerned for improving performance in future
4	VERY GOOD	No further action
5	EXCELLENT	Appreciation Letter to the concern

- iv) Reply from the concerned Vendor/Supplier/Contractor/Consultant shall be examined by EIC. In case of satisfactory reply, Performance Rating data sheet to be closed with a letter to the concerned for improving performance in future.
- v) When no reply is received or reasons indicated are unsatisfactory, the following actions need to be taken based on recommendations of site level committee and HO level committee:

The methodology for processing of cases of "POOR" (as per Performance Rating) shall be as under:

E-Tender No.: AGL/Head Office/Contract and Purchase/22/25-26/ET/22
[METERING SKIDS]
ANNUAL RATE CONTRACT (02 YEARS) FOR SUPPLY OF METERING SKIDS

- i) *Within 7 days of issuance of explanation Letter by EIC or no reply/receipt of non-satisfactory reply to explanation letter for "Poor" Performance Rating, site level committee will recommend the case to HO level committee.*
- ii) *On receipt of above details from Site level committee, HO level committee will take approval from Competent Authority and accordingly HOD (C&P) will issue Advisory notice (duly vetted by Law Department) to Vendor/Supplier/Contractor/Consultant for putting them on watch list for a Period of Three (03) Years.
The copy of Advisory notice will also be sent to all OICs/HoDs for instructing EICs to closely monitor the performance of such Vendor/Supplier/Contractor/Consultant in other ongoing/new Orders/Contracts placed on them.
Simultaneously AGL's SAP/Portal will be Yellow Flagged for such Vendor.*
- iii) *For the case of "Subsequent Instances" in other ongoing order (s)/ contract (s) or new order (s)/ contract (s) on such Vendor/Supplier/Contractor/Consultant, the matter will be deliberated by the site level committee and recommendations to be forwarded to C&P for further deliberation by a HO Level Committee consisting of following:
(1) HOD (C&P)
(2) HOD (F&A)
(3) HOD (HSE-Q)
(4) HOD of Concerned department.
All other subsequent process of committee recommendation for issuance of Show Cause Notice (SCN) cum suspension order, vetting of same etc will be as per vendor performance.
On receipt of reply to SCN, C&P will forward the same to concerned OIC/HoD at HO for point wise reply to issues brought out by Vendor/Supplier/Contractor/Consultant in their reply to show cause notice.
On receipt of recommendation from site committee through OIC/HoD at HO, the matter will once again be deliberated by the aforesaid HO level committee. All other subsequent process of committee recommendation for keeping the Vendor/Supplier/Contractor/Consultant on holiday or otherwise, vetting of speaking order, approval etc. will be as per vendor performance.*

- A) **Where Performance rating is "POOR"** (as per Performance rating carried out after execution of Order/Contract and where no reply/unsatisfactory reply is received from party against the letter seeking the explanation from Vendor/Supplier/Contractor/Consultant along with Sharing the Performance rating)

Recommend such defaulting Vendor/Supplier/Contractor/Consultant for the following action:

1. Poor Performance on account of Quality (if marks obtained against Quality parameter is less than 20):
 - a) **First Instance: Holiday (Red Card) for Two Years, and effect of Holiday will be as mentioned in Clause No. 2.7**
 - b) **Subsequent instance (s) in other ongoing order (s) / contract (s) or new order (s) / contract (s) on such Vendor/ Supplier/ Contractor/ Consultant: Holiday (Red Card) for Three Years**
2. Poor Performance on account of other than Quality (if marks obtained against Quality parameter is more than 20):
 - a) **First such instance: Advisory notice (Yellow Card)** shall be issued and Vendor/Supplier/Contractor/Consultant shall be put on watch list for a period of Three (03) Years.
 - b) **Second such instance in other ongoing order (s) / contract (s) or new order (s) / contract (s) on such Vendor/ Supplier/ Contractor/ Consultant: Putting on Holiday (red Card) for a period of One Year.**



E-Tender No.: AGL/Head Office/Contract and Purchase/22/25-26/ET/22
[METERING SKIDS]
ANNUAL RATE CONTRACT (02 YEARS) FOR SUPPLY OF METERING SKIDS



c) Subsequent instances (more than two) in other ongoing order (s) / contract (s) or new order (s) / contract (s) on such Vendor/ Supplier/ Contractor/ Consultant: Putting on Holiday (Red Card) for Three Years

(B) Where Poor/Non-Performance leading to termination of contract or offloading of contract due to poor performance attributable to Vendor/Supplier/Contractor/Consultant (under relevant Contract Clauses)

(a) **First Instance: Advisory notice (Yellow Card)** shall be issued and Vendor/Supplier/Contractor/Consultant shall be put on watch list for a period of Three (3) Years.

Further such vendor will not be allowed to participate in the re-tender of the same supply/work/services of that location which has terminated/offloaded. Moreover, it will be insured that all other action as per provision of contract including forfeiture of Contract Performance Security (CPS) etc. are undertaken.

However, such vendor will be allowed to participate in all other tenders and to execute other ongoing order/contract (s) or new contract / order (s).

The Yellow card will be automatically revoked after a period of three years unless the same is converted into Red Card due to subsequence instances of poor/non-performance in other ongoing order (s)/ contract (s) or new order (s)/ contract (s) on such Vendor/Supplier/Contractor/Consultant.

(b) **Second instances** in other ongoing order (s)/ contract (s) or new order (s)/ contract (s) on such Vendor/Supplier/Contractor/Consultant: **Holiday (Red Card)** for period of One Year and they shall also to be considered for suspension.

(c) **Subsequent instances (more than two)** in other ongoing order (s)/ contract (s) or new order (s)/ contract (s) on such Vendor/Supplier/Contractor/Consultant: **Holiday (Red card) for period of Three Years and they shall also to be considered for suspension.**

A provision in AGL's SAP/Portal will be made for flagging (**Yellow card and Red card**) of such Vendor/Supplier/Contractor/Consultant so as to track their performance. List of such Vendor/Supplier/Contractor/Consultant shall also be uploaded on the AGL's intranet/web site.

Further, the bidder status regarding Yellow card should be mentioned in the **TCR/Proposal for Price Bid Opening** so that delivery/execution may be closely monitored by the concerned.

2.5.2 FOR CONSULTANCY JOBS

Monitoring and Evaluation of consultancy jobs will be carried out in the same way as described above in 2.5.1 except the functions of Project Manager will be performed by concerned In-charges of user departments such as Project, Marketing, HR, Finance, HSE etc.

2.5.3 FOR OPERATION & MAINTENANCE:

- i) Evaluation of performance of Vendors/Suppliers/Contractors/Consultants in case of Operations and maintenance shall be done within 30 days of execution of order/contract or Completion of Contract.
- ii) After execution of orders/contracts a Performance Rating Data Sheet (Format enclosed) shall be prepared by respective Engineer-in-Charge excluding cases under Para 2.4.
- iii) Depending upon the Performance Rating, following action need to be initiated by Engineer-in-charge:

Sl. No.	Performance rating	Action
1	POOR	Seek explanation for Poor performance
2	FAIR	Seek explanation for Fair performance
3	GOOD	Letter to the concerned for improving performance in future
4	VERY GOOD	No further action
5	EXCELLENT	Appreciation Letter to the concern

- iv) Reply from the concerned Vendor/Supplier/Contractor/Consultant shall be examined. In case of satisfactory reply, Performance Rating data sheet to be closed with a letter to the concerned for improving performance in future.
- v) When no reply is received or reasons indicated are unsatisfactory, the following actions need to be taken based on recommendations of site level committee and HO level committee:

The methodology for processing of cases of "POOR" (as per Performance Rating) shall be as under:

- i) *Within 7 days of issuance of explanation Letter by EIC or no reply/receipt of non-satisfactory reply to explanation letter for "Poor" Performance Rating, site level committee will recommend the case to HO level committee.*
- ii) *On receipt of above details from Site level committee, HO level committee will take approval from Competent Authority and accordingly HOD (C&P) will issue Advisory notice (duly vetted by Law Department) to Vendor/Supplier/Contractor/Consultant for putting them on watch list for a Period of Three (03) Years.
The copy of Advisory notice will also be sent to all OICs/HoDs for instructing EICs to closely monitor the performance of such Vendor/Supplier/Contractor/Consultant in other ongoing/new Orders/Contracts placed on them.
Simultaneously AGL's SAP/Portal will be Yellow Flagged for such Vendor.*
- iii) *For the case of "Subsequent Instances" in other ongoing order (s)/ contract (s) or new order (s)/ contract (s) on such Vendor/Supplier/Contractor/Consultant, the matter will be deliberated by the site level committee and recommendations to be forwarded to C&P for further deliberation by a HO Level Committee consisting of following:*
 - (5) HOD (C&P)
 - (6) HOD (F&A)
 - (7) HOD (HSE-Q)



E-Tender No.: AGL/Head Office/Contract and Purchase/22/25-26/ET/22
[METERING SKIDS]
ANNUAL RATE CONTRACT (02 YEARS) FOR SUPPLY OF METERING SKIDS



(8) *HOD of Concerned department.*

All other subsequent process of committee recommendation for issuance of Show Cause Notice (SCN) cum suspension order, vetting of same etc will be as per vendor performance.

On receipt of reply to SCN, C&P will forward the same to concerned OIC/HoD at HO for point wise reply to issues brought out by Vendor/Supplier/Contractor/Consultant in their reply to show cause notice.

On receipt of recommendation from site committee through OIC/HoD at HO, the matter will once again be deliberated by the aforesaid HO level committee. All other subsequent process of committee recommendation for keeping the Vendor/Supplier/Contractor/Consultant on holiday or otherwise, vetting of speaking order, approval etc. will be as per vendor performance.

- A) **Where Performance rating is “POOR”** (as per Performance rating carried out after execution of Order/Contract and where no reply/unsatisfactory reply is received from party against the letter seeking the explanation from Vendor/Supplier/Contractor/Consultant along with Sharing the Performance rating)

Recommend such defaulting Vendor/Supplier/Contractor/Consultant for the following action:

1. Poor Performance on account of Quality (if marks obtained against Quality parameter is less than 20):
 - a) First Instance: Holiday (Red Card) for Two Years, **and effect of Holiday will be as mentioned in Clause No. 2.7**
 - b) Subsequent instance (s) in other ongoing order (s) / contract (s) or new order (s) / contract (s) on such Vendor/ Supplier/ Contractor/ Consultant: Holiday (Red Card) for Three Years
2. Poor Performance on account of other than Quality (if marks obtained against Quality parameter is more than 20):
 - a) First such instance: Advisory notice (Yellow Card) shall be issued and Vendor/Supplier/Contractor/Consultant shall be put on watch list for a period of Three (03) Years.
 - b) Second such instance in other ongoing order (s) / contract (s) or new order (s) / contract (s) on such Vendor/ Supplier/ Contractor/ Consultant: Putting on Holiday (red Card) for a period of One Year.
 - c) Subsequent instances (more than two) in other ongoing order (s) / contract (s) or new order (s) / contract (s) on such Vendor/ Supplier/ Contractor/ Consultant: Putting on Holiday (Red Card) for Three Years

(B) Where Poor/Non-Performance leading to termination of contract or offloading of contract due to poor performance attributable to Vendor/Supplier/Contractor/Consultant (under relevant Contract Clauses)

- (a) **First Instance: Advisory notice (Yellow Card)** shall be issued and Vendor/Supplier/Contractor/Consultant shall be put on watch list for a period of Three (3) Years.

Further such vendor will not be allowed to participate in the re-tender of the same supply/work/services of that location which has terminated/offloaded. Moreover, it will be insured that all other action as per provision of contract including forfeiture of Contract Performance Security (CPS) etc. are undertaken.

However, such vendor will be allowed to participate in all other tenders and to execute other ongoing order/contract (s) or new contract / order (s).

The Yellow card will be automatically revoked after a period of three years unless the same is converted into Red Card due to subsequent instances of poor/non-performance in other ongoing order (s)/ contract (s) or new order (s)/ contract (s) on such Vendor/Supplier/Contractor/Consultant.

- (b) **Second instances** in other ongoing order (s)/ contract (s) or new order (s)/ contract (s) on such Vendor/Supplier/Contractor/Consultant: **Holiday (Red Card)** for period of One Year and they shall also to be considered for suspension.
- (c) **Subsequent instances (more than two)** in other ongoing order (s)/ contract (s) or new order (s)/ contract (s) on such Vendor/Supplier/Contractor/Consultant: **Holiday (Red card) for period of Three Years and they shall also to be considered for suspension.**

A provision in AGL Portal will be made for flagging (**Yellow card and Red card**) of such Vendor/Supplier/Contractor/Consultant so as to track their performance. List of such Vendor/Supplier/Contractor/Consultant shall also be uploaded on the AGL's web site. Further, the bidder status regarding Yellow card should be mentioned in the **TCR/Proposal for Price Bid Opening** so that delivery/execution may be closely monitored by the concerned.

2.6 REVIEW & RESTORATION OF PARTIES PUT ON HOLIDAY

An order for Holiday passed for a certain specific period shall deemed to have been automatically revoked on the expiry of that specified period and it will not be necessary to issue a specific formal order of revocation.

Further, in case Vendor/Supplier/Contractor/Consultant is put on a Holiday due to quality, and new order is placed on bidder after restoration of Vendor/Supplier/Contractor/Consultant, such order will be properly monitored during execution stage by the concerned site incharge.

2.7 EFFECT OF HOLIDAY

- A) If a Vendor/Supplier/Contractor/Consultant is put on Holiday, such Vendor/Supplier/Contractor/Consultant should not be considered in ongoing tenders/future tenders.
- B) However, if such Vendor/Supplier/Contractor/Consultant is already executing any other order/contract and their performance is satisfactory in terms of the relevant contract, should be allowed to continue till its completion without any further increase in scope except those incidental to original scope mentioned in the contract. In such a case CPBG will not be forfeited and payment will be made as per provisions of concerned contract. However, this would be without prejudice to other terms and condition of the contract.
- C) Effect on other ongoing tendering:
 - i) After issue of the enquiry/bid/tender but before opening of Technical bid, the bid submitted by the party shall be ignored.
 - ii) After opening of the Technical bid but before opening the Price bid, the Price bid of the party shall not be opened and BG/EMD submitted by the party shall be returned to the party.
 - iii) After opening of Price, BG/EMD made by the party shall be returned; the offer of the party shall be ignored & will not be further evaluated. If errant party emerges as the lowest (L-1), then such tender shall also be cancelled and re-invited.

- 2.8 While putting the Vendor/Supplier/Contractor/Consultant on holiday as per the procedure, the holding company, subsidiary, joint venture, sister concerns, group

division of the errant Vendor/Supplier/Contractor/Consultant shall not be considered for putting on holiday list.

Any Bidder, put on holiday, will not be allowed to bid through consortium route also in new tender during the period of holiday.

- 2.9** In an unsuccessful bidder makes any vexatious, frivolous or malicious complaint against the tender process with the intention of delaying or defeating any procurement or causing loss to AGL or any other bidder, such bidder will be put on holiday for a period of six months, if such complaint is proved to be vexatious, frivolous or malicious, after following the due procedure.

2.10 APPEAL AGAINST THE DECISION OF THE COMPETENT AUTHORITY

- a) The party may file an appeal against the order of the Competent Authority for putting the party on Holiday list. The appeal shall be filed to Appellate Authority. Such an appeal shall be preferred within one month from the date of receipt of Holiday order.
- b) Appellate Authority would consider the appeal and pass appropriate order which shall be communicated to the party as well as the Competent Authority.
- c) Appeal process may be completed within 45 days of filing of appeal with the Appellate Authority.
- d) Appellate Authority” shall mean Committee of nominee director of either GAIL or HPCL other than Chairman of the AGL Board and Executive management i.e. Managing Director and Director (Commercial) of Aavantika Gas Limited.

2.11 ERRANT BIDDER

In case after price bid opening the lowest evaluated bidder (L-1) is not awarded the job for any mistake committed by him in bidding or withdrawal of bid or modification of bid or varying any term in regard thereof leading to re-tendering, AGL shall forfeit EMD paid by the bidder and such bidders shall be debarred from participation in retendering of the same job(s)/item(s).

Further, such bidder will be put on watch List (Yellow card) for a period of three years after following the due procedure. However, during the period in watch list such vendor will be allowed to participate in all other tenders and to execute other ongoing order/contract (s) or new contract/ order (s).

In case of subsequent instances of default in other tender(s) during aforesaid watch list period, the action shall be initiated as per provision of Sl. No. 2 of Para (A) of Clause no. 2.5.1 (v).

The Yellow card will be automatically revoked after specified period unless the same is converted into Red Card.

- 2.12** In case GST department or any other Statutory department brings to the notice of AGL that a party has not paid to the credit of the Government the GST or any Statutory payment collected from AGL, then party will be put on holiday for a period of Six months after following the due procedure, including holding his payment.

- 2.13** All departments other than Projects like O&M, HSE, HR, F&A, Marketing etc. will be covered under definition of O&M.



E-Tender No.: AGL/Head Office/Contract and Purchase/22/25-26/ET/22
[METERING SKIDS]
ANNUAL RATE CONTRACT (02 YEARS) FOR SUPPLY OF METERING SKIDS



2.14 Further, **PERFORMANCE RATING DATA SHEET** (FOR PROJECTS/CONSULTANCY JOBS/O&M) is enclosed for reference for Evaluation of Performance of Vendors/ Suppliers/ Contractors/ Consultants.

2.15 Site level committee of Three members shall be formed for location other than Indore (HO), comprising of OIC of the location and available senior most members at the location of User and HSE-Q department.

Site level committee of Two members shall be formed for Indore location, comprising of available senior most members of User and HSE-Q department below HOD level.

2.16 As per the recommendations received from Site level Committee and HO level Committee, Head of the C&P department has to take Approval from Competent Authority prior issuing any letter to vendor regarding putting a vendor on a Watch list or Holiday list.

However, Show Cause/Explanation notices for putting vendors on Watch list or Holiday list may be issued by HOD of user department or HOD (C&P).



**E-Tender No.: AGL/Head Office/Contract and Purchase/22/25-26/ET/22
[METERING SKIDS]
ANNUAL RATE CONTRACT (02 YEARS) FOR SUPPLY OF METERING SKIDS**



**AAVANTIKA GAS LIMITED
PERFORMANCE RATING DATA SHEET**

- (i) Project/Work Centre :
- (ii) Order/Contract No. & Date :
- (iii) Brief description of Items Works/Assignment:
- (iv) Order/Contract value (Rs.) :
- (v) Name of Vendor/Contractor/ Supplier/Consultant :
- (vi) Contractual delivery/ Completion Schedule:
- (vii) Actual delivery/ Completion date:

Performance Parameter	Delivery/Completion Performance	Quality Performance	Reliability Performance#	Total
Maximum Marks	40	40	20	100
Marks Allocated (*)				

Note:
Remarks (if any)

PERFORMANCE RATING ()**

Note:

- (#) Vendor/Supplier/Contractor/Consultant who seek repeated financial assistance or deviation beyond contract payment term or seeking direct payment to the sub-vendor/ sub-contractor due to financial constraints, then '0' marks should be allotted against Reliability Performance.
- (*) Allocation of marks would be as per enclosed instructions
- (**) Performance rating shall be classified as under:

Sl. No.	Range (Marks)	Rating
1.	60 & below	POOR
2.	61 - 70	FAIR
3.	71 - 80	GOOD
4.	81 - 90	VERY GOOD
5.	MORE THAN 90	EXCELLENT

Signature of Authorized signatory with Name & Designation

INSTRUCTIONS FOR ALLOCATION OF MARKS

Marks are to be allocated as under:

i. DELIVERY/COMPLETION PERFORMANCE: 40 MARKS

Delivery Period / completion Schedule		Delay in Weeks	Marks
a)	Up to 3 months	Before CDD	40
		Delay up to 3 weeks	35
		Delay up to 6 weeks	30
		Delay up to 9 weeks	25
		Delay up to 12 weeks	20
		Delay up to 15 weeks	15
		More than 15 weeks	0
b)	Above 3 months	Before CDD	40
		Delay up to 4 weeks	35
		Delay up to 8 weeks	30
		Delay up to 10 weeks	25
		Delay up to 16 weeks	20
		Delay up to 20 weeks	15
		Delay up to 24 weeks	10
		More than 24 weeks	0

ii. QUALITY PERFORMANCE 40 MARKS

For Normal Cases: No Defects/No Deviation/No failure: 40 marks

i)	Rejection/Defects	Marks to be allocated on pro-rata basis for acceptable quantity as compared to total quantity for normal cases	10 Marks
ii)	When quality failure endangers the system integration and safety of the system.	Failure of severe nature - Moderate nature - low severe nature	0 marks 5 marks 10-25 marks

**E-Tender No.: AGL/Head Office/Contract and Purchase/22/25-26/ET/22
[METERING SKIDS]
ANNUAL RATE CONTRACT (02 YEARS) FOR SUPPLY OF METERING SKIDS**

iii)	Number of deviations	No. deviation	5 Marks
		No. of deviations <=2	2 marks
		No. of deviations >2	0 marks

**iii. RELIABILITY PERFORMANCE
FOR WORKS / CONTRACTS**

20 MARKS

i) Submission of order acceptance, agreement, PBG, 4 marks

	Drawings and other documents within time	
ii)	Mobilization of resources as per Contract and in time	4 marks
iii)	Liquidation of Check-list points	4 marks
iv)	Compliance to statutory and HS & E requirements Or Reliability of Estimates/Design/Drawing etc. in case of Consultancy jobs	4 marks
v)	Timely submission of estimates and other documents for Extra, Substituted & AHR items	4 marks

FOR SUPPLIES

i)	Submission of order acceptance, PBG , Drawing and other documents within time	5 marks
ii)	Attending complaints and requests for after Sales service/warranty repairs and/or query/advice (up to the evaluation period)	5 marks
iii)	Response to various correspondence and conformance to standards like ISO	5 marks
iv)	Submission of all required documents including Test Certificates at the time of supply	5 marks

EIC Signature:

EIC Remarks:

SECTION III

PAYMENT TERMS

PAYMENT TERMS:

100% (GST Compliant Invoice value) of the total supply order (PO) price (per Metering Skid) will be paid against receipt of ordered item(s) by owner at site within 30 days of receipt and acceptance of bills at site against relevant documents as mentioned in order:

- i) Invoice
- ii) Inspection Release note by Owner or his appointed or approved agency.
- iii) GR / LR in Original
- iv) Packing List
- v) Insurance cover note covering transit insurance
- vi) A certificate from manufacturer that the all items/ equipment under supply including its component or raw material used with manufacturing are new and conform to the tender requirement.
- vii) Performance Bank Guarantee(s) of 10% of Delivery Order Value. If already submitted, a copy of the same.
- viii) Document related to Input Tax Credit to be claimed by Owner, if applicable.
- ix) Documents as specified in the Technical Specifications / Material Requisitions of Tender Document
- x) Proof of customs clearance including payment of custom duty for imports permitted in the contract.
- xi) No Dues No Claim Certificate (if applicable)

MODE OF PAYMENT:

Payment will be made by way of normal banking channels.

Deduction at source

Purchaser will release the payment after off-setting all dues to the Purchaser payable by the seller under the contract. Deduction will be effected at source as per the law in force.

PERFORMANCE BANK GUARANTEE: Within 15 days from issuance of Purchase Order, the successful bidder shall furnish the performance guarantee in the form of Bank Guarantee to the PURCHASER, for an amount equivalent to 10% of the Purchase Order value (Excluding taxes & duties)



E-Tender No.: AGL/Head Office/Contract and Purchase/22/25-26/ET/22
[METERING SKIDS]
ANNUAL RATE CONTRACT (02 YEARS) FOR SUPPLY OF METERING SKIDS



SECTION IV

TECHNICAL SPECIFICATION

Scope of Annual Rate Contract (ARC) Supply, Work and Technical Specification for Industrial Metering Skids for Natural Gas application

SCOPE OF SUPPLY / WORK:

This covers requirement of scope of Supply & Work, Fabrication, Assembling, Construction features, Inspection and Testing of Industrial Metering Skids of 150# pressure class rating being procured under annual rate contract:

1. The scope of supply and works shall include all the activities of engineering, fabrication, assembling, inspection, testing, supply, loading / unloading at AGL store, quality assurance and quality control of the system and documentation with the turnkey responsibility and meet the requirements, its objectives, functional and specific requirements described in the specifications and taking care of complete requirements.
2. The scope of supply includes 2", 3" & 4" seamless Steel Pipe, necessary spool pieces, Ball valves, Cartridge Gas Filter, Filter Bypass assembly as per requirement, Box type Skid enclosure, Transition Fittings, Pressure Gauge, Angle & Channel for support, Elbow, Flanges, Gasket, Studs, Anchor bolts and other works required to complete the job as per the attached skid drawing. However, Companion flanges of sizes 2" / 3" / 4" shall be given by AGL as free issue.
3. Alignment of the Skid can be Horizontal or vertical.
4. Scope of supply also includes packing, forwarding (for suitable storage/ preservation), loading, unloading, transportation and transit insurance for delivery of skids at **AGL's Dhanuka store** located at Indore-Ujjain road.
5. The Metering SKID shall be manufactured as per all the requirements of PNGRB Technical Standard T4SE and as per this technical specification. All Other relevant standards and requirements shall also govern design and engineering of Metering SKID. Bidder shall seek clarification (if any) in this regard before bid submission. Unless otherwise specified, the latest edition of the standards mentioned herein this specification, including all addenda and revisions, shall apply.
6. The design & fabrication of the skids shall be such that each of its equipment / component is easily accessible, operable and maintainable and the same shall not obstruct the operation and maintenance of any other equipment in the skid or part thereof. Unless otherwise specified, the pressure indicated in this tender document is gauge pressure.
7. Furnishing of as built documentation, drawings, reports, certificates and other information required here-in including operation and maintenance manuals of the equipment supplied / installed in skid.
8. Type and model number of all components of Metering SKID shall be mentioned clearly in the offer.
9. AGL reserves the right to accept / reject the offer of the bidder based on the past performance of their product(s) in AGL, or elsewhere.

Process Parameter / Condition:

Metering SKID shall be designed for following process parameter:

Design pressure : 07 Bar

Skid rated Flow Rate : As per SOR and Technical Datasheet

Bidder Seal & Sign

NATURAL GAS- CLEAN ENERGY, GREEN ENERGY



E-Tender No.: AGL/Head Office/Contract and Purchase/22/25-26/ET/22
[METERING SKIDS]
ANNUAL RATE CONTRACT (02 YEARS) FOR SUPPLY OF METERING SKIDS



Inlet Pressure (range) : 3 – 5 Bar
Outlet Pressure (range) : 3 – 5 Bar
Required RPD Meter : As per SOR and Technical Datasheet

SPECIFICATION & TECHNICAL REQUIREMENTS:

1. The line/ valve sizes mentioned in tender drawing is minimum line size/ port/ nozzle size of each component of Metering SKID package. Components should be selected for maximum designed gas flow rate at the minimum pressure (inlet/ outlet as the case may be). All pressure parts shall be designed for design pressure and temperature. Unless specified & clarified by AGL, above sizes to be followed for all mainline valves and nozzle size.
2. All the materials selected for skid equipment/component shall be as per data sheet.
3. Complete Metering SKID shall be designed for 07 Kg/cm²g pressure. All pipe, fitting and equipment must be capable of withstanding the maximum pressure resulting from a fault condition.
4. Pressure test points, pressure gauges, shall be provided as specified in the diagram provided in tender. All the ends of drain shall be blinded/ plugged.
5. Technical literature in English language, along with dimensional details of the equipment and system hook up drawing shall be submitted by bidder along with the technical bid.
6. Schematic line diagram of Metering SKID provided in tender shall be used for guidance purpose. Before fabrication, actual arrangement shall be proposed in soft & hard form by the vendor, for review and approval by AGL. No procurement/ fabrication job shall be undertaken/ started without written approval of AGL.
7. Vendor list provided in tender for bought out items shall be followed for procurement of bought out items required in Metering SKID.
8. The data sheet (provided with tender) should be filled up completely, signed, stamped and enclosed along with catalogue and drawings in the Technical Bid submitted by the bidder.
9. Compliance with Technical Specification will be taken for granted, if deviations are not specifically mentioned during bid submission.
10. Any deviation to tender condition/ specification shall lead to rejection of bid.
11. Only flanged and welded connection shall be used in Metering SKID. Unless clarified/ specified by AGL, no threaded connection shall be used. Only blind plugs for drain connection can have threaded connection.
12. Hole tight / leak tight shall not be used on threaded / flange joints. For all flange joints, Stud with nuts (hot dip galvanized) shall be provided on flange joints. All Studs and nut used in this project shall be hot dip galvanized as per ASTM A153 or equivalent.
13. No valve Components like Valve body, bonnet, cover and / or end flanges made of cast iron or ductile iron shall be used.
14. No Flange made of cast iron, ductile iron or non-ferrous materials (brass or bronze) shall be used in skid. All instruments fitting/ tubing etc shall be of SS316. No tube fitting/ tube of brass/ copper shall be used.

Bidder Seal & Sign

NATURAL GAS- CLEAN ENERGY, GREEN ENERGY

15. Cartridge Gas Filter shall be installed at the upstream of the RPD meter as per the specified drawing. Cartridge Gas filter should have 5 micron filtration capacity with borosilicate fiber glass element, manual drain arrangement and Differential Pressure Gauge (DPG) mounted on it. The Filters to be installed shall be in accordance with ASME Section-8, Boiler & Pressure vessel code.
16. Some of the Metering Skids shall be having Filter Bypass assembly, to facilitate uninterrupted Gas supply, during maintenance work on Filter for those Industrial customers having continuous operations.
17. Skid should be enclosed in a Box type Structure having vertical structural steel support with base frame along with 16 gauge (2 mm) thickness canopy with locking arrangement of door.
18. Suitable transition fittings, 2", 3" or 4" (required for connecting to MDPE pipes) shall be provided at inlet of Metering SKID.
19. The Metering Skid shall be duly installed along with RPD meter with EVC, Strainer, NRV, Modem, Power supply, Communication cables, Pulse cables and other AMR related accessories with required mounting arrangement and accessories as per best engineering practices.
20. Metering SKID shall have pressure gauges provided at outlet of the Meter, mounted suitably in the Skid so as to view it from outside.
21. Metering SKID design shall meet various requirements of national/ international standards such as ANSI B-31.3/31.8; ASME Sec. VIII, Div-I; EN-12279; EN-12186; IGE-TD-13; AGA-5, AGA-7 & AGA-8 and PED 97/23/EC Compliance.
22. Skids shall have Lifting arrangement of adequate strength provided to facilitate its Lifting, Transportation and convenience in handling.
23. All pipe work and equipment must be capable of withstanding the maximum pressure resulting from a fault condition.
24. RPD flow meter (provided in Metering SKID) shall be positioned in such a way that the index can be read conveniently. When viewing the index, the gas flow direction through the meter is from the left to the right.
25. Installation arrangement for guidance is as shown in the schematic drawing enclosed. Actual arrangement should be proposed by vendor and shall be reviewed / approved by AGL.
26. Compliance with Technical Specification will be taken for granted by AGL, if deviations are not specifically mentioned and accepted by AGL. Any deviation from the specified technical specification, vendor list, datasheet etc should be highlighted by vendor. However, the acceptance of the same shall be at the sole discretion of AGL.
27. Provision for anchoring skid (on foundation) shall be provided by bidder. Supply of suitable anchor bolts (preferably of 16 mm size) also lies in bidder's scope.

PIPE WORK, FITTINGS & GENERAL CONSTRUCTION:

- Metering SKID skid construction / fabrication, reinforcement pads, etc. shall meet the requirements of codes ASME B31.8: 2007 and or ASME BPV Code, Section VIII: 2007. The design and assembly of all the equipment shall be such that there is no difficulty in the operation and maintenance of the same. The material used for manufacturing of the pipes and fittings shall be as per standard. Components made of cast iron shall not be used in manufacturing.

- Pipe work and fittings shall be of seamless type and as per ASTM A 106 Gr. B / API 5L Gr. B and ASTM A 234 Gr. WPB & ASTM A 105 respectively. All branch connections should be of weldolet type up to d/D ratio less than 0.3 and Sweepolet type up to d/D ratio less than 0.6. All valves for pressure / vent, pressure gauge and bleed should have positive blind arrangement.
- Size of sensing line and pressure test points shall be minimum ½”size..
- Welders and welding procedures have to be qualified in accordance with ASME BPV Code Section IX / API 1104. All the welded joints should be radio-graphically examined and acceptance criteria should comply with ASME BPV Code, Section VIII / API 1104.
- The Ball valve of the Skid shall be easily accessible and it should indicate the directions of opening as well as closing. The direction of flow of gas in the piping system of the skid shall be indicated on the pipes.
- Painting of pipes, skid components, JB, enclosure, cabinet, support and other metal components (as applicable) shall be carried out by application of one coat (DFT 45-50 microns) of zinc phosphate primer followed by two coats
- (DFT 100 microns each) of chloro rubber high build paint of colour canary yellow. Before painting, surfaces shall be thoroughly cleaned by applying mechanical methods.
- The height of the Skid shall be around 1 meter from the Skid foundation in case of horizontal alignment of the Skid and minimum thickness for angle & channel used for support shall be minimum 5 mm.
- Skid shall be enclosed in a Box type Structure having vertical structural steel support with base frame along with 16 gauge (upto 2 mm) thickness canopy with locking arrangement of door
- The minimum 200 mm distance has to be maintained between the canopy and the component of Metering SKID and also maintain the sufficient distance between the canopy and skid component, in order to ensure the easy operation and maintenance of the same.
- The copper jumper (flat of 3 to 4 mm thickness and appropriate width) shall be provided at each flange connections. Ends of copper jumper shall be such that it will be removed only after opening the studs provided. The inlet and outlet matching flanges/ companion flange/ Restriction Orifice plate/ Transition fitting (as the case may be) with blind, stud, nut and gaskets shall be provided..

FOUNDATION DETAILS:

- Manufacturer shall furnish the details of foundation and anchoring/ grouting pockets requirement. Suitable hole shall be provided for anchoring/ grouting the Skid. Anchor fasteners/ foundation bolts of adequate strength shall be supplied by the bidder. Bidder shall supply additional anchor fasteners bolts-nuts set (25% extra) along with shipment..

TESTS:

Hydro Testing: Hydro testing of the skid shall be carried out using water as the testing medium. The test pressure shall be 1.5 times the design pressure and holding time for the test shall be 30 min. Wherever necessary, ball valves and similar components that have been tested independently should be removed from the line. Blind flanges or double flange pipes should be installed temporarily in their place. All small bore connections and impulse lines should be disconnected and suitable plugs or blank flanges should be installed.

Test Certificates: A record of all hydrotesting carried out should be prepared for every installation and provided during inspection. A material test certificate for all components of Metering Skids should be furnished at the time of inspection by third party / AGL representative. AGL reserves the right to witness all the tests.

PERFORMANCE AND INSPECTION:

Manufacturing Test Certificates (MTC) for all components / parts of Metering SKID, NDT results, Welding Procedure Specification (WPS), Welder's Performance Qualification Record (WPQR), Welding Procedure Qualification Record (PQR), etc., should be made available prior to offering the complete skid for witnessing the performance testing by AGL / Third party Inspection agency appointed by Bidder.

The final performance test of complete Metering SKID skid shall be carried out in presence of third party inspecting agency / AGL representative before accepting the skid and giving clearance for dispatch. Inspection is to be carried out as per inspection plan stated below.

Inspection Plan:

- a) Visual inspection of Metering SKID assembly.
- b) Witnessing of:
 - i) Hydro testing of Metering SKID assembly, as per parameters given in tender.
 - ii) Performance setting & operation of Ball valves.
- iii) Performance setting & operation of Filters.
- c) Stage-wise inspection to be carried out for inspection of workmanship quality and for inspection of surface preparation and primer coat / intermediate coats to ensure proper adhesion / paint quality.
- d) Review of all Calibration certificates, test certificates for all the Ball Valves, filtration and measuring instruments at the time of inspection, i.e. used for checking and testing, along with the calibration certificate of the master instruments from which the instruments is calibrated.
- e) All Test reports to be submitted before dispatch Clearance.

DOCUMENTATION REQUIRED METERING SKID:

Manufacturer shall submit 2 sets of hard copies and one (1) digital copy on Compact Disc of following documents along with each skid (in English language only):

- a) Bill of Material
- b) P&ID (Process and Instrumentation Diagram) and GAD (General Arrangement Drawing)
- c) Approved Quality Assurance Plan
- d) Catalogs of each component of Metering SKID
- e) Material test certificate for all the pipe and fittings material and traceability records.
- f) Filter – Construction drawing, flow calculation, cartridge details & specification
- g) Pressure Gauge / Instrument Calibration Certificates
- h) WPS, WPQR and PQR vetted by TPIA
- i) Non Destructive Test reports vetted by TPIA
- j) Dimensional check report
- k) Painting Specification and report
- l) Hydro & Pneumatic test certificates
- m) Warranty Certificate
- n) Operation and maintenance instruction manual & requirement
- o) Start up and commissioning procedure
- p) Specify the weight of the skid

SR . NO	AGL specification	Requirements	Vendor's Offer	Deviation s, if any	Remarks
A	INLET / OUTLET BALL VALVE				
1	MAKE	VENDOR TO SPECIFY			
2	TYPE/ MODEL	VENDOR TO SPECIFY			
3	STANDARD	API 6D (LATEST)			
4	NOMINAL SIZE (INCH / NB)	As per Skid Size			
5	PRESSURE CLASS	ANSI 150# for Metering SKID Inlet & Outlet			
6	SERVICE	NATURAL GAS			
7	PATTERN	FULL BORE			
8	END CONNECTIONS	FLANGED, RAISED FACE			
9	VALVE OPERATOR	LEVER OPERATED (UPTO 4") GEAR OPERATED (6" & ABOVE)			
10	MATERIAL SPECIFICATION (EQVT. OR SUPERIOR)				
a	BODY	ASTM A 216 Gr. WCB/ A 234 WPB/ A 350 LF2			
b	BALL	SS 304/ ASTM A 182 Gr. F6 / F			
c	STEM	SS304/ ASTM A 182 Gr. F6 / F 304			
d	STEM SEAL	PTFE			
e	STUD BOLTS / NUTS	ASTM A 193 Gr B7 / ASTM A 194			
11	OTHER REQUIREMENTS				
a	VALVE TYPE / DESIGN	1 PIECE CONSTRUCTION / BOLTED 2 PIECE CONSTRUCTION			
b	BALL MOUNTING	Floating design.			
c	STEM DESIGN	ANTI BLOW OUT TYPE			
d	ANTI STATIC DESIGN	YES			
e	BALL POSITION INDICATOR	OPEN / CLOSE INDICATOR REQUIRED			
f	MECHANICAL STOPS	FOR OPEN / CLOSE LIMITS REQUIRED			
g	FIRE SAFE DESIGN	API 607 / API 6 FA (LATEST)			
h	SEALANT INJECTION POINT	REQUIRED for 6" and Above			
i	BODY VENT	REQUIRED for 6" and Above			
j	OPERATING VALVE WHEEL/HANDLE	IN CASE OF GEAR OPERATED VALVE ROUND SHAPED WHEEL IS REQUIRED			

SR. NO.	AGL specification	Requirements	Vendor's Offer	Deviations, if any	Remarks
B.	ISOLATION VALVES	FOR PRESSURE GAUGE, Sensing lines & OTHER SMALL BORE VALVES (BELOW 2") for Vent/ Drain			
1	MAKE	VENDOR TO SPECIFY			
2	TYPE / MODEL	VENDOR TO SPECIFY			
3	STANDARD	BS EN ISO 17292: 2004			
4	NOMINAL SIZE (INCH)	TO BE SPECIFIED BY VENDOR			
5	PRESSURE CLASS	ANSI 800#			
6	SERVICE	NATURAL GAS			
7	PATTERN	FULL BORE			
8	END CONNECTIONS	SOCKET WELDING ENDS			
9	VALVE OPERATOR	LEVER OPERATED			
10	MATERIAL SPECIFICATION (EQVT. OR SUPERIOR)				
a	BODY	ASTM A 105			
b	BALL	SS304/ ASTM A 182 Gr. F6 / F			
c	STEM	SS304/ ASTM A 182 Gr. F6 / F			
d	STEM SEAL	PTFE			
11	OTHER REQUIREMENTS				
a	VALVE TYPE / DESIGN	BALL VALVE, 1 PIECE CONSTRUCTION / BOLTED 2			
b	STUD BOLTS / NUTS	A 193 Gr B7 / A 194 Gr 2H			
c	BALL MOUNTING	FLOATING TYPE			
d	STEM DESIGN	ANTI BLOW OUT TYPE			
e	ANTI STATIC DESIGN	YES			
f	BALL POSITION INDICATOR	OPEN / CLOSE INDICATOR REQUIRED			
g	MECHANICAL STOPS	FOR OPEN / CLOSE LIMITS REQUIRED			
h	FIRE SAFE DESIGN	API 607 / API 6FA (LATEST)			

SR. NO.	AGL specification	Requirements	Vendor's Offer	Deviations, if any	Remarks
C	PRESSURE GAUGE				
1	MAKE	VENDOR TO SPECIFY			
2	MODEL	VENDOR TO SPECIFY			
3	STANDARD	BS EN 837			
4	TYPE	BOURDON			
5	MOUNTING	DIRECT (through ½" NPT tapping)			
6	DIAL SIZE	100 MM			
7	WINDOW MATERIAL	SHATTER PROOF GLASS.			
8	PRESSURE ELEMENT	SS 316			
9	ACCURACY	+/- 1% of SCALE RANGE			
	RANGE	0 – 10 BAR			
11	Connection	½" NPT			
12	2-way Isolation valve	Required (for process inlet, gauge and			

SR. NO.	AGL specification	Requirements	Vendor's Offer	Deviations, if any	Remarks
D	DRY GAS FILTERS				
1	MAKE	VENDOR TO SPECIFY			
2	TYPE / MODEL	VENDOR TO SPECIFY			
3	TYPE	CARTRIDGE/INLINE			
4	FILTRATION SIZE	5 Micron			
5	EFFICIENCY	98% or better			
6	DESIGN (FLOW DIRECTION)	OUT-TO-IN TYPE			
7	MAXIMUM WORKING PRESSURE	19 Bar as per design rating			
8	CONNECTION DETAILS	FLANGED END ANSI 150#			
9	DESIGN & CONSTRUCTION	AS PER ASME CODE, SECTION VIII: Div			
10	DUST CONCENTRATION	UPTO 0.1 mg/SCM or better			

11.	DUST COLLECTION CAPACITY	15 DAYS at design flow rate			
-----	-----------------------------	-----------------------------	--	--	--

SR. NO.	AGL specification	Requirements	Vendor's Offer	Deviations, if any	Remarks
E	PIPE WORK & FITTINGS				
1	PIPE WORK	API 5L Gr B or ASTM A 106 Gr. B			
2	FITTINGS	ASTM A 234 GR WPB, ASTM A 105			

List of Vendors for Bought out items for Metering Skids:

Dry gas Filter:

- M/s Ultra filter
- M/s Multitex Filters Pvt Ltd
- M/s Nirmal Industrial Controls Pvt Ltd
- M/s Inel Gas Controls Pvt Ltd
- M/s Grandprix
- M/s PECO – USA
- M/s Forain, Italy
- M/s Flashpoint Equipment Pvt Ltd
- M/s Filtration Engineers India Pvt Ltd

Ball Valve / Isolation (Ball/Needle) Valve:

- M/s Larsen & Toubro (Audco India Ltd)
- M/s Microfinish
- M/s Flowchem
- M/s Virgo Engineers
- M/s Oswal Industries Ltd
- M/s Shayburg
- M/s Petro
- M/s Hi-Flow / Hina
- M/s Hawa Valves
- M/s BDK Engineering

Line Pipe:

- M/s Jindal Pipes
- M/s Maharashtra Seamless Ltd
- M/s Surya Roshni Ltd
- M/s Welspun



E-Tender No.: AGL/Head Office/Contract and Purchase/22/25-26/ET/22
[METERING SKIDS]
ANNUAL RATE CONTRACT (02 YEARS) FOR SUPPLY OF METERING SKIDS



- M/s PSL Ltd
- M/s Indian Seamless Metal Tube Ltd
- M/s Jindal Saw Ltd

Transition Fittings (TF):

- M/s Jain Irrigation System
- M/s George Fisher
- M/s Kimplas Piping Systems
- M/s Al-Aziz Plastics Pvt Ltd
- M/s Ali Axis utilities & insustry pvt ltd

Pressure Gauge/ Diff Pressure gauge:

- M/s Warea Instruments
- M/s Wika
- M/s Hirlekar
- M/s FGB
- M/s General Instrument

SS FITTINGS / TUBING.

- M/s SWAGELOK (USA)
- M/s PARKER (USA)
- M/s Sandvik (for Tubing)

Note:

Bidder shall take prior approval of the make / model no of the offered item and it shall be from the above list.

However additional vendors will be considered based on our past experience, only in exceptional case(s), provided they have supplied for similar application to reputed natural gas transmission / distribution companies, in quantities at least half the numbers being supplied in this tender and working satisfactorily for minimum 12 months period. Documentary evidence substantiating above shall be submitted for taking our approval for any other vendor other than listed above.

DATASHEET FOR CARTRIDGE FILTER : 3"			
PROJECT:		Pressure regulating skid	
GENERAL			
1	Type Of Filter	Cartridge Type,Horizontal	
2	Service	Natural Gas	
3	Size (Inlet/Outlet)	3" NB x 3" NB	
4	Design Rating/Pressure	300#	49 Barg
5	End Connection	300# Raised Face (Serration 125-250 AARH) As Per ANSI B16.5	
SERVICE CONDITIONS			
6	Fluid / State	Natural Gas (G)	
7	Flow Rate(Min/Opr/Max)	-	SCMH
8	Inlet Pr.(Min/Opr/Max)	25	Bar g
10	Corosion Allowance	3mm	
MATERIAL CONSTRUCTION			
11	Shell	A106 Gr. B	
12	Dish End/Bottom	A 234 Gr. WPB	
13	Shell Flange/ Size	A105 / 8"x 300#	
14	Cover Flange	A105	
15	I/L & O/L Nozzle MOC / Size	A106 Gr. B / 3",SCH40 & 3",SCH40	
16	I/L & O/L Nozzle Flange/ Size	A105 / 3"x300# & A105/3"X300#	
17	Gasket	Spiral Wound SS304 + GRAPHITE FILLER	
18	Fastners	ASTM A193 Gr.B7 & ASTM A194 Gr.2H	
19	Filter Element	Borosilicate Glass Fibre	
20	Element Type	Cartridge Type	
21	Filtration Size	05 µ	
22	Filtration Eff.	98%	
23	Flow Direction	Outlet To Inlet	
24	Element Code , Size	OD X ID X L = 75X40X250 Lg.	
25	Element QTY.	3 NOS.	
OTHER			
26	PSV Connection	1"X 300#	
27	VENT CONNECTION	1" SW X 3000#	
28	DRAIN CONNECTION	1" SW X 3000#	
29	DP Gauge Connection	1/2" SW X 3000#	
30	Painting	AS PER APPROVED PAINT SPEC	
31	Inspection & Testing	As Per QAP	

DATASHEET FOR CARTRIDGE FILTER : 4"				
PROJECT	NATURAL GAS PRESSURE REGULATING SKID			
GENERAL				
1	Type Of Filter	: Cartridge Type,Horizontal		
2	Service	: Natural Gas		
3	Size (Inlet/Outlet)	: 4" NB x 4" NB		
4	Design Rating/Pressure	: 300#	19 Barg	
5	End Connection	: 150# Raised Face (Serration 125-250 AARH) As Per ANSI B16.5		
SERVICE CONDITIONS				
6	Fluid / State	: Natural Gas (G)		
7	Flow Rate(Min/Opr/Max)	: -	-	400 SCM
8	Inlet Pr.(Min/Opr/Max)	: 1.5	3.5	4 Bar g
10	Vapor Pr. / Critical Pr.	: -		
11	Corosion Allowance	: 1.5		
MATERIAL CONSTRUCTION				
12	Shell	: A106 Gr. B 10"		
13	Dish End/Bottom	: A 234 Gr. WPB		
14	Shell Flange/ Size	: A105 / 4" x 150#		
15	Cover Flange	: A105		
16	Nozzle MOC / Size	: A106 Gr. B / 4" X SCH 40		
17	I/L & O/L Nozzle Flange/ Size	: A105 / 4"x300#		
18	Gasket	: Spiral Wound SS304 + GRAPHITE FILLER		
19	Fastners	: ASTM A193 Gr.B7 & ASTM A194 Gr.2H		
20	Filter Element	: Borosilicate Glass Fibre		
21	Element Type	: Cartridge Type		
22	Filtration Size	: 05 µ		
23	Filtration Eff.	: 98%		
24	Flow Direction	: Outlet To Inlet		
25	Element Code , Size	: OD X ID X L = 75X40X750 Lg.		
26	Element QTY.	: 3 NOS.		
OTHER				
27	Drain Connection	: 10"x1/2" SW x 3000#		
28	DP Gauge Connection	: 10"x1/2"SW x 3000#		
29	PSV + VENT Connection	: 10"x 1"SW x 3000#		
30	Painting	: Suitable to Corrosive Enviroment As Per Manufacturer		
31	Inspection & Testing	: As Per QAP		

		QUALITY ASSURANCE PLAN				QAP No.:		PROJECT : Metering SKID			
						DATE:		Job No. :			
CLIENT: M/s		MANUFACTURE'S NAME & ADDRESS:									
P.O. NO. :										Sheet No.	
SR No	Description	Characteristic	Class	Type of Check	Quantum of Check	Reference Documents	Acceptance Norms	Format of Records	Inspection By		CLIENT/T PI
									M	vendor	
1	Drawings & Calculations										
1.1	GAD, BOM, QAP for skid, Mechanical Datasheet, Instrument Datasheet, FAT	Complete Skid	Major	Submittals	100%	Technical Spec. and Datasheets	Approved Datasheet	Manufacturers Format	-	P	R
2	Incoming Material Identification of Broughtout Items										
2.1	Ball valves	Material TC for valves	Major	Sr. No. verification / verification with datasheet	100%	Approved Datasheet	Approved Datasheet	MFR'S. TC / Compliance	P	R	R
		Dimension- Size, Rating, End connection	Major	Visual, Measurement	100%	Approved Datasheet	Approved Datasheet	MFR'S. TC / Compliance	P	R	W
		Testing of valves (Body hydro,hydro seat/backseat,air seat)/applicable test	Major	Leak Test	100%	Approved Datasheet / Manufacturing STD	Approved Datasheet / Manufacturing STD	MFR'S. TC / Compliance	P	R	
2.2	Pressure Gauges , Diff. Pressure Gauge	Calibration, Accuracy, Range, Size, Dimension & End connection	Major	Visual, Measurement	100%	Approved Datasheet	Approved Datasheet	MFR'S. TC / Compliance	P	R	R
2.3	Pipe, Pipe Fitting, Flanges for Interconnecting Piping	Material TC, Size & Dimension	Major	Chemical Analysis, Physical Test, Size & Rating	100%	Approved Piping Material Spec	Approved Piping Material Spec	MFR'S. TC / Compliance	P	R	R
3	Equipment										
3.1	Dry Gas Filter	Raw Material -Material TC, Size & Dimension	Major	Chemical Analysis, Physical Test, Size & Rating	100%	Approved Piping Material Spec	Approved Piping Material Spec	MFR'S. TC / Compliance	P	R	R
3.2		WPS & PQR	Major	Welders Qualification &	100%	As per ASME SEC. IX	As per ASME SEC. IX	WPS / PQR from Record	--	P	R
3.3		In Process Inspection	Major	Fit Up	100%	Approved Drawing	Approved Drawing & Standards	Reports	--	P	R
3.4		DP test on Fillet Welds	Major	Surface Defects	100%	As per ASME SEC. V	As per ASME SEC. VIII Div: 1	Reports	--	P	R
3.5		Radiography after Final Weld	Major	Internal Defects	Full	As per ASME SEC. V	As per ASME SEC. VIII Div: 1	Reports	--	P	R

3.6	Visual & Dimensional Check	Major	Surface Finish & Dimensions	100%	Approved Drawing	Approved Drawing	Reports	--	P	R
3.7	Hydro Test	Major	Strength	100%	Approved Drawing	1.3 times of Design Pressure	Reports	--	P	R

		QUALITY ASSURANCE PLAN					QAP No.:		PROJECT : Metering SKID		
							DATE:		Job No. :		
CLIENT: M/s							MANUFACTURE'S NAME & ADDRESS:				
P.O. NO. :									Sheet No.		
SR No	Description	Characteristic	Class	Type of Check	Quantum of Check	Reference Documents	Acceptance Norms	Format of Records	Inspection By		CLIENT/TPI
									M	vendor	
4	Welding, NDT & Testing for Interconnecting Piping										
4.1	WPS / PQR	WPS / PQR	Major	Welders Qualification & Welding	100%	Approved WPS / PQR	As per ASME SEC. IX	WPS / PQR	-	P	R
4.2	D P T of fillet weld joints	To identify external surface defects	Major	Dye Penetration test	100% of total joints	ASME Sec V	ASME SEC.31.3	Internal Inspection Report	-	P	R
4.3	Radiography Test	To identify internal surface defects on Buttweld joints	Major	Radiographic test	100% all Butt weld joints (including Vent & Drain)	ASME Sec V	ASME SEC.31.3 (table 341.3.2, Normal & Category M fluid), ASME Sec V	Interpretation Report	-	P	R
4.4	Hydro Testing of Interconnecting Piping	Hydro Testing 10.5 Barg for 150#	Major	Strength	100%	Approved P&ID & GAD	As per ASME SEC.31.8 & IGE/TD/13	Inspection Report	-	P	W



**E-Tender No.: AGL/Head Office/Contract and Purchase/22/25-26/ET/22
[METERING SKIDS]
ANNUAL RATE CONTRACT (02 YEARS) FOR SUPPLY OF METERING SKIDS**



QUALITY ASSURANCE PLAN						QAP No.:		PROJECT : Metering SKID			
						DATE:		Job No. :			
CLIENT: M/s						MANUFACTURE'S NAME & ADDRESS:					
P.O. NO. :						Sheet No.					
SR No	Description	Characteristic	Class	Type of Check	Quantum of Check	Reference Documents	Acceptance Norms	Format of Records	Inspection By		CLIENT/ TPI
									M	Vendor	
5 Final Inspection of Skid Assembly											
5.1	Final Dimensional/ Visual Inspection	Complete Skid	Major	Visual Inspection	100%	Approved P&ID & GAD	Approved Data Sheet	Reports	-	P	R
5.2	Painting of Skid	Painting	Major	Visual & Final DFT measurement	100%	Approved Painting Spec.	Approved Painting Spec.	Reports	-	P	W
5.3	Factory Acceptance Test	as per approved FAT procedure	Major	Performance Test	100%	Approved Data Sheet	Approved Data Sheet	FAT Report	-	P	W
6 Final Documentation:											
6.1	Material compliance report as per EN 10204 3.1 Calibration Certificate, GAD and P & ID , Final FAT report NDT reports, Hydro/Pneumatic Test reports, Test certificate of ball valves	History docket	Major	Verification of records	100%	Approved specification	As per approved specification	History Docket	-	P	R
3.2 certificate required											
Made By:		Checked By:		M : Manufacturer P : Performer W : Witness ; H : Hold				Approved By:			
				Legend: R : Review ; A: Approval; RW: Random Witness V : Verification				M/s			

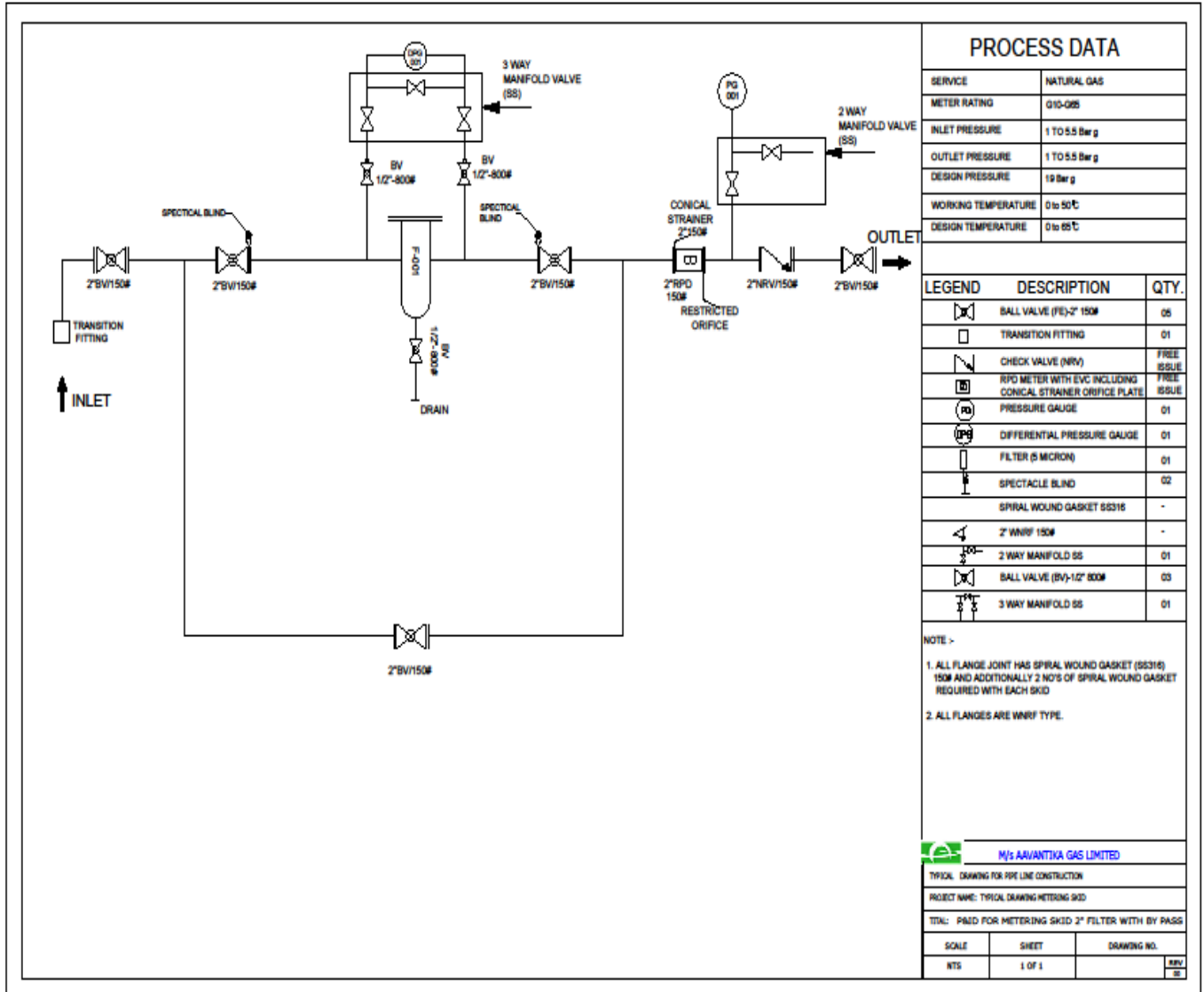

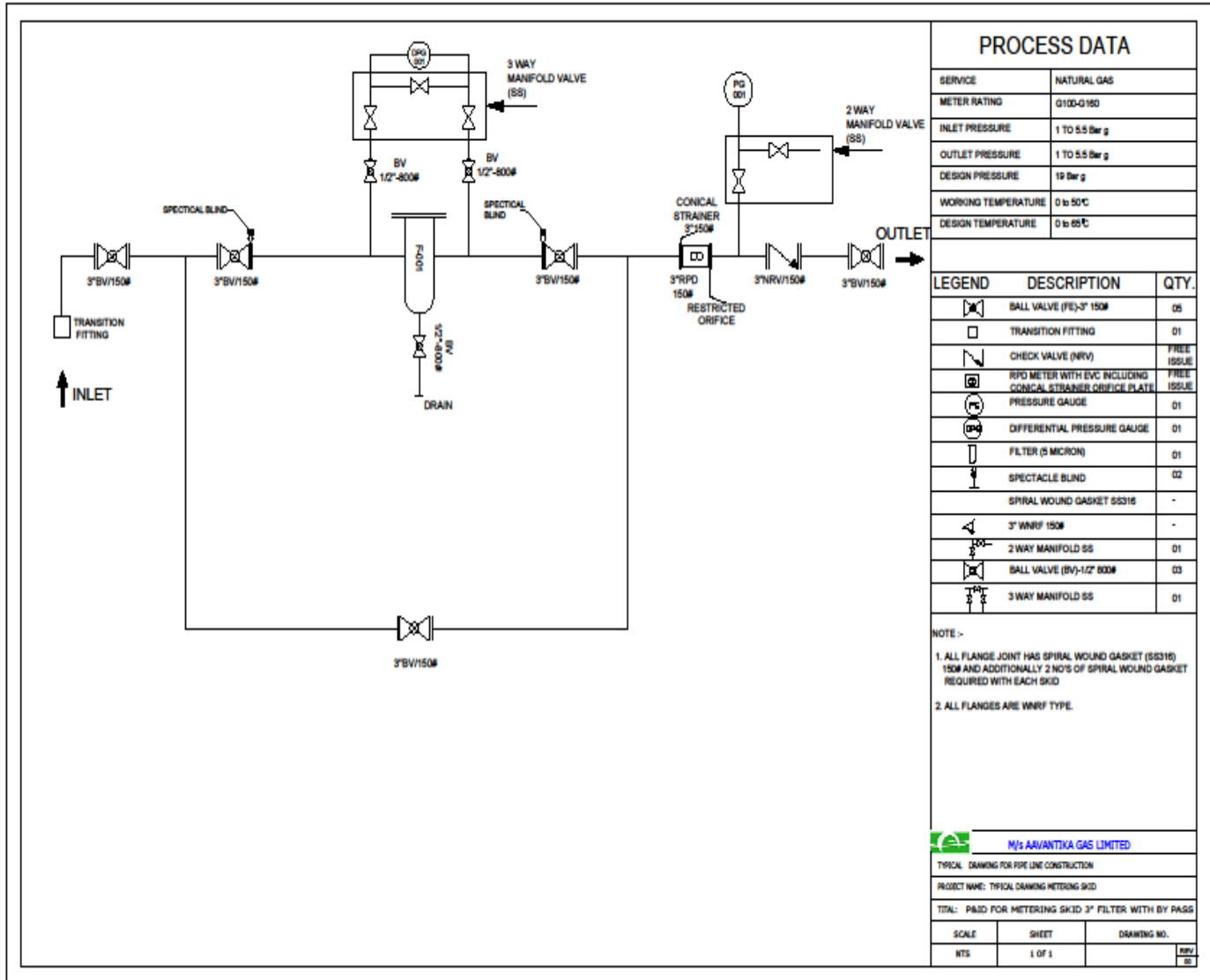

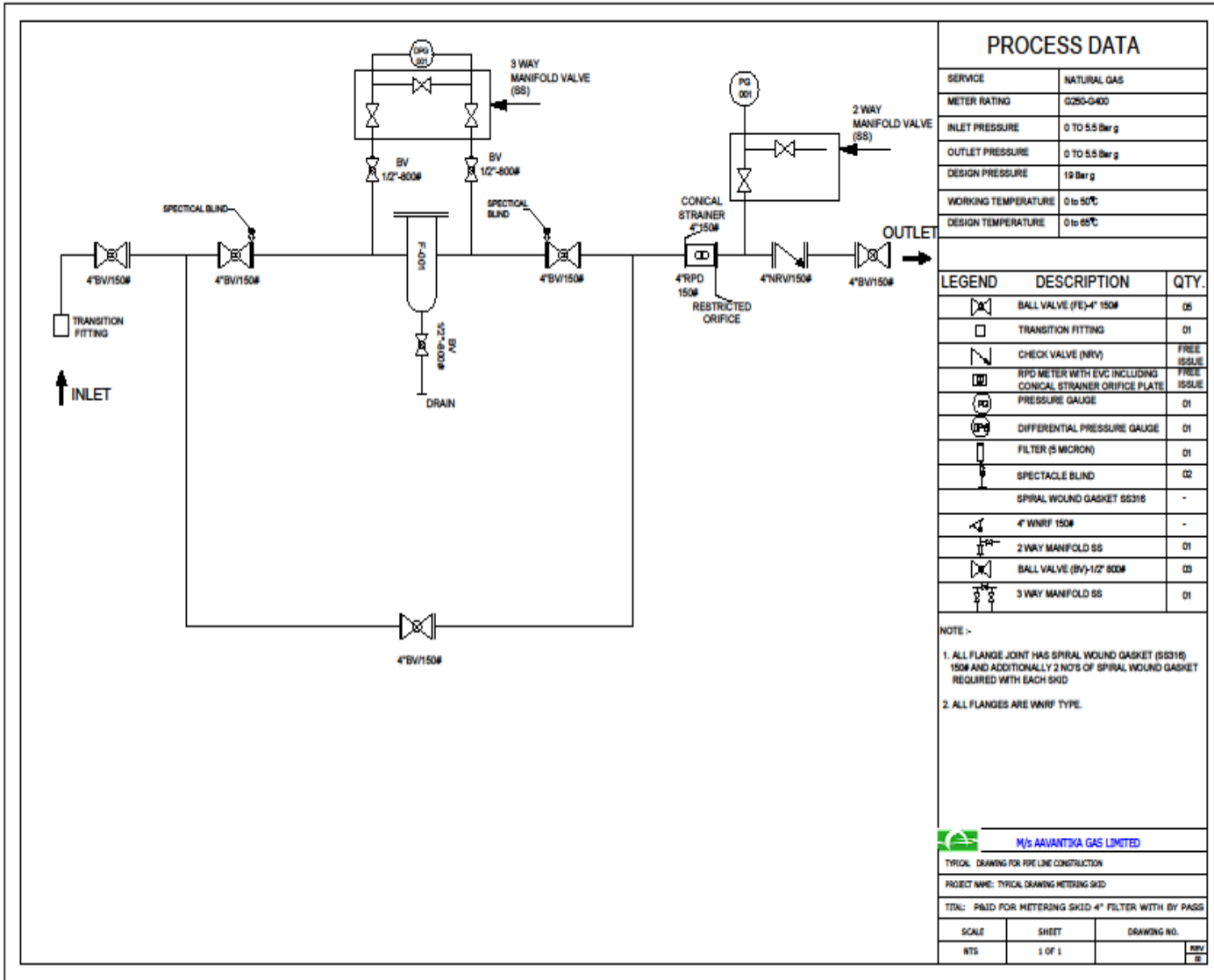

BILL OF MATERIAL						
SR. NO.	COMPONENT	DESCRIPTION	TAG NO.	QTY	MAKE/MODEL	LOCATION
SIZE: I/L: 2" X 150#, O/L: 2" X 150 #						
PART A (Isolation Valves)						
1	Isolation Ball Valves	2"x150# Isolation Ball Valve; Floating ball type, Body : A216 Gr WCB, Ball & Stem : SS, Flanged End, Fire safe design:API6FA, Lever operated.	IV-101 TO IV-104	2 /4	REPUTED	At I/L & Filter Bypass & O/L
2	Small Ball Valve	½" 800#, 3-piece Full bore ball valves, ASTM A 105 Body & Socket Weld End Connection, NPT(MXF)	VBS	1	REPUTED	For PG
3	NRV	Size:2"x150#, Non Return Valve, Body:C.S., End Connection: Flange End	NRV-101	1	FREE ISSUE	At Outlet
PART B (Equipment and Metering)						
4	Filter Assembly	Cartridge Gas filter :inlet 2"x150# / outlet:2"x150#, borosilicate fiber glass element, Filtration 50 µ or better with Manual Drain Arrangement	CF-101	1	REPUTED	At Inlet
5	Conical Strainer	2" conical Strainer in SS Construction having 50µ, Up Stream of Meter.	CST	1	FREE ISSUE	At Inlet of meter
6	RPD Meter	Size:2"x150#, Rotary Positive Displacement type of Flow meter with Electronic Volume corrector.	RPD METER	1	FREE ISSUE	At Outlet Of Skid
PART D (Field Instruments)						
7	Pressure Gauge	Pressure Gauge, Range - 0 to 6 kg/cm ² g 4" Dial Size; SS304 Case; ½" NPT Bottom Conn	PG	1	Baumer/GIC/Reputed	At Inlet & Outlet of Skid
PART E (Piping & Fittings)						
8	Transition Fitting	Size:2"x150#, Transtion Fittings	TF	1	REPUTED	At Inlet
9	Restriction Orifice	Size:2"x150#, Restriction Orifice	RO	1	FREE ISSUE	
10	Piping, fitting	Piping & Fitting: Pipes: A106 Gr.B, Flanges & Fittings: A105 & A234 Gr. WPB, Gasket: Spiral wound either CS inner & outer, Stud & Nut: B7 / 2H.	-	1	Pipefit/MSL/Reputed Make	-
11	Fabrication Cost	Welding & Fabrication Cost of Skid with Radiography.	-	1	REPUTED	-
12	Structural Steel	Vertical Structural Steel Support with Base Frame	-	1	REPUTED	-
13	Canopy	16 gauge 2 m.m. thickness canopy with locking arrangement of door.	-	1	REPUTED	-
14	Painting & Name Plate	Painting (Powder Coating) & Name Plate for Skid	-	1	REPUTED	-

BILL OF MATERIAL

SR. NO.	COMPONENT	DESCRIPTION	TAG NO.	QTY	MAKE/MODEL	LOCATION
SIZE: I/L: 3" X 150#, O/L: 3" X 150 #						
PART A (Isolation Valves)						
1	Isolation Ball Valves	3"x150# Isolation Ball Valve; Floating ball type, Body : A216 Gr WCB, Ball & Stem : SS, Flanged End, Fire safe design:API6FA, Lever operated.	IV-101 TO IV-102	2/4	REPUTED	At I/L & Filter Bypass & O/L
2	Small Ball Valve	½" 800#, 3-piece Full bore ball valves, ASTM A 105 Body & Socket Weld End Connection, NPT(MXF)	VBS	1	REPUTED	For PG
3	NRV	Size:3"x150#, Non Return Valve,Body:C.S.,End Connetion:Flange End	NRV-101	1	FREE ISSUE	At Outlet
PART B (Equipments and Metering)						
4	Filter Assembly	Cartridge Gas filter :inlet 3"x150# / outlet:3"x150#, borosilicate fiber glass element, Filtration 5µ or better with Manual Drain Arrangement,DPG Mounted on it	CF-101	1	REPUTED	At Inlet
5	Conical Strainer	3" conical Strainer in SS Construction having 50µ, Up Stream of Meter.	CST	1	FREE ISSUE	At Inlet of meter
6	RPD Meter	Size:3"x150#,Rotary Positive Displacement type of Flow meter with Electronic Volume corrector.	RPD METER	1	FREE ISSUE	At Outlet Of Skid
PART D (Field Instruments)						
7	Pressure Gauge	Pressure Gauge, Range - 0 to 6 kg/cm2g 4" Dial Size; SS304 Case; ½" NPT Bottom Conn	PG	1	Buamer/GIC/Reputed	At Inlet & Outlet of Skid
PART E (Piping & Fittings)						
8	Transtion Fitting	Size:3"x150#,Transtion Fittings	TF	1	REPUTED	At Inlet
9	Restriction Orifice	Size:3"x150#, Restriction Orifice	RO	1	FREE ISSUE	
10	Piping, fitting	Piping & Fitting: Pipes: A106 Gr.B, Flanges & Fittings: A105 & A234 Gr. WPB, Gasket: Spiral wound eith CS inner & outer, Stud & Nut: B7 / 2H.	-	1	Pipefit/MSL/Reputed Make	-
11	Fabrication Cost	Welding & Fabrication Cost of Skid with Radiography.	-	1	REPUTED	-
12	Structural Steel	Vertical Structural Steel Support with Base Frame	-	1	REPUTED	-
13	Canopy	16 gauge 2 m.m. thickness canopy with locking arrangement of door.	-	1	REPUTED	-
14	Painting & Name Plate	Painting (Powder Coating) & Name Plate for Skid	-	1	REPUTED	-

BILL OF MATERIAL

SR. NO.	COMPONENT	DESCRIPTION	TAG NO.	QTY	MAKE/MODEL	LOCATION
SIZE: I/L: 4" X 150#, O/L: 4" X 150 #						
PART A (Isolation Valves)						
1	Isolation Ball Valves	4"x150# Isolation Ball Valve; Floating ball type, Body : A216 Gr WCB, Ball & Stem : SS, Flanged End, Fire safe design:API6FA, Lever operated.	IV-101 TO IV-102	2	REPUTED	At I/L & Filter Bypass & O/L
2	Small Ball Valve	½" 800#, 3-piece Full bore ball valves, ASTM A 105 Body & Socket Weld End Connection, NPT(MXF)	VBS	1	REPUTED	For PG
3	NRV	Size:4"x150#, Non Return Valve,Body:C.S.,End Connction:Flange End	NRV-101	1	FREE ISSUE	At Outlet
PART B (Equipments and Metering)						
4	Filter Assembly	Cartridge Gas filter :inlet 3"x150# / outlet:3"x150#, borosilicate fiber glass element, Filtration 5µ or better with Manual Drain Arrangement,DPG Mounted on it	CF-101	1	REPUTED	At Inlet
4	Conical Strainer	4" conical Strainer in SS Construction having 50µ, Up Stream of Meter.	CST	1	FREE ISSUE	At Inlet of meter
5	RPD Meter	Size:4"x150#,Rotary Positive Displacement type of Flow meter with Electronic Volume corrector.	RPD METER	1	FREE ISSUE	At Outlet Of Skid
PART D (Field Instruments)						
6	Pressure Gauge	Pressure Gauge, Range - 0 to 6 kg/cm2g 4" Dial Size; SS304 Case; ½" NPT Bottom Conn	PG	1	Buamer/GIC/Reputed	At Inlet & Outlet of Skid
PART E (Piping & Fittings)						
7	Transtion Fitting	Size:4"x150#,Transtion Fittings	TF	1	REPUTED	At Inlet
8	Restriction Orifice	Size:4"x150#, Restriction Orifice	RO	1	FREE ISSUE	
9	Piping, fitting	Piping & Fitting: Pipes: A106 Gr. B, Flanges & Fittings: A105 & A234 Gr. WPB, Gasket: Spiral wound eith CS inner & outer, Stud & Nut: B7 / 2H.	-	1	Pipefit/MSL/Reputed Make	-
10	Fabrication Cost	Welding & Fabrication Cost of Skid with Radiography.	-	1	REPUTED	-
11	Structural Steel	Vertical Structural Steel Support with Base Frame	-	1	REPUTED	-
12	Canopy	16 gauge 2 m.m. thickness canopy with locking arrangement of door.	-	1	REPUTED	-
13	Painting & Name Plate	Painting (Powder Coating) & Name Plate for Skid	-	1	REPUTED	-



E-Tender No.: AGL/Head Office/Contract and Purchase/22/25-26/ET/22
[METERING SKIDS]
ANNUAL RATE CONTRACT (02 YEARS) FOR SUPPLY OF METERING SKIDS



SECTION V

GENERAL CONDITIONS OF CONTRACT (GCC-GOODS)



E-Tender No.: AGL/Head Office/Contract and Purchase/22/25-26/ET/22
[METERING SKIDS]
ANNUAL RATE CONTRACT (02 YEARS) FOR SUPPLY OF METERING SKIDS



INDEX

Article	Title
1.	Definitions
2.	Seller To Inform
3.	Application
4.	Country of Origin
5.	Scope of Contract
6.	Standards
7.	Instructions, Direction & Correspondence
8.	Contract Obligations
9.	Modification In Contract
10.	Use of Contract Documents & Information
11.	Patent Rights, Liability & Compliance of Regulations
12.	Performance Guarantee
13.	Inspectison, Testing & Expediting
14.	Time Schedule & Progress Reporting
15.	Delivery & Documents
16.	Transit Risk Insurance
17.	Transportation
18.	Incidental Services
19.	Spare Parts, Maintenance Tools, Lubricants
20.	Guarantee
21.	Terms of Payment
22.	Prices
23.	Subletting & Assignment
24.	Time As Essence of Contract
25.	Delays in The Seller's Performance
26.	Price Reduction Schedule For Delayed Delivery
27.	Rejections, Removal of Rejected Equipment & Replacement
28.	Termination of Contract
29.	Force Majeure
30.	Resolution of Disputes / Arbitration
31.	Governing Language
32.	Notices
33.	Taxes & Duties
34.	Books & Records
35.	Permits & Certificates
36.	General
37.	Import License
38.	Fall Clause
39.	Publicity & Advertising
40.	Repeat Order
41.	Limitation of Liability

1.0 Definitions

In this document, General Conditions of Contract (GCC-Goods), the following terms shall have the following respective meanings:

- 1.0 BIDDER: Designates the individual or legal entity, which has made a proposal, a tender, or a bid with the aim of concluding a Contract with the PURCHASER.
- 1.1 CONTRACT shall mean Purchase Order/Contract and all attached exhibits and documents referred to therein and all terms and conditions there of together with any subsequent modifications there to.
- 1.2 CONTRACT PRICE shall mean the price payable to the Seller under the Contract for the full and proper performance of his contractual obligations.
- 1.3 COMPLETION DATE shall mean the date on which the goods are successfully commissioned by the Seller and handed over to the PURCHASER.
- 1.4 COMMERCIAL OPERATION shall mean the condition of the operation in which the complete equipment covered under the Contract is officially declared by the PURCHASER to be available for continuous operation at different loads upto and including rated capacity.
- 1.5 DELIVERY terms shall be interpreted as per INCO TERMS 2000 in case of Contract with a foreign Bidder and as the date of LR/GR in the case of a contract with an Indian Bidder.
- 1.6 DRAWINGS shall mean and include Engineering drawings, sketches showing plans, sections and elevations in relation to the Contract together with modifications and/or revisions there to.
- 1.7 ENGINEER or Engineer-in-Charge of the Project SITE shall mean the person designated from time to time by PURCHASER at SITE and shall include those who are expressly authorized by him to act for and on his behalf for operation of this CONTRACT.
- 1.8 FINAL ACCEPTANCE shall mean the PURCHASER's written acceptance of the Works performed under the Contract after successful completion of performance and guarantee test.
- 1.9 GOODS shall mean articles, materials, equipment, design and drawings, data and other property to be supplied by Seller to complete the contract.
- 1.10 INSPECTOR shall mean any person or outside Agency nominated by PURCHASER to inspect equipment, stage-wise as well as final, before dispatch, at Seller's works and on receipt at SITE as per terms of the CONTRACT.

- 1.11 INITIAL OPERATION shall mean the first integral operation of the complete equipment covered under the Contract with sub-systems and supporting equipment in service or available for service.
- 1.12 PURCHASER / OWNER shall mean AAVANTIKA GAS LIMITED (AGL) having its registered office at NRK Business Park, 2nd Floor, 202-B, Vijay Nagar Square, A.B. Road, Indore (M.P), Pin – 452010. The term PURCHASER includes successors, assigns of AGLL.
- 1.13 PERFORMANCE AND GUARANTEE TESTS shall mean all operational checks and tests required to determine and demonstrate capacity, efficiency and operating characteristics as specified in the Contract documents.
- PROJECT designates the aggregate of the Goods and/or Services to be provided by one or more Contractors. Quantities – Bills of quantities Bills of quantities
- Designate the quantity calculations to be taken into account when these calculations are made from detailed or construction drawings, or from work actually performed, and presented according to a jointly agreed breakdown of the Goods and/or Services.
- 1.14 SELLER shall mean the person, firm or company with whom PURCHASE ORDER/CONTRACT is placed/entered into by PURCHASER for supply of equipment, materials and services. The term Seller includes its successors and assigns.
- 1.15 SERVICE shall mean erection, installation, and testing, commissioning, provision of technical assistance, training and other such obligations of the Seller covered under the Contract.
- 1.16 SITE designates the land and/or any other premises on, under, in or across which the Goods and/or Services have to be supplied, erected, assembled, adjusted, arranged and/or commissioned.
- 1.17 SPECIFICATIONS shall mean and include schedules, details, description, statement of technical data, performance characteristics, standards (Indian as well as International) as applicable and specified in the Contract.
- 1.18 SUB-CONTRACT shall mean order placed by the Seller, for any portion of the contracted work, after necessary consent and approval of PURCHASER.
- 1.19 SUB-CONTRACTOR shall mean the person named in the CONTRACT for any part of the work or any person to whom any

part of the CONTRACT has been sub-let by the SELLER with the consent in writing of the PURCHASER and will include the legal representatives, successors, and permitted assigns of such person.

- 1.20 START-UP shall mean the time period required to bring the equipment's covered under the Contract from an inactive condition, when construction is essentially complete to the state of readiness for trial operation. The start-up period shall include preliminary inspection and check out of equipment and supporting subsystems, initial operation of the complete equipments covered under the Contract to obtain necessary pre-trial operation data, perform flow calibration and corrective shutdown inspection and adjustment prior to the trial operation period.
- 1.21 TESTS shall mean such process or processes to be carried out by the Seller as are prescribed in the Contract or considered necessary by PURCHASER or his representative in order to ascertain quality, workmanship, performance and efficiency of equipment or part thereof.
- 1.22 TESTS ON COMPLETION shall mean such tests as prescribed in the Contract to be performed by the Seller before the Works are taken over by the PURCHASER.

2.0 Seller To Inform 2.1 The Seller shall be deemed to have carefully examined all Contract documents to his entire satisfaction. Any lack of information shall not in any way relieve the Seller of his responsibility to fulfill his obligation under the Contract.

3.0 Application 3.1 These General Conditions of Contract (GCC-Goods) shall apply to the extent that they are not superseded by provisions of other parts of the Contract.

4.0 Country of Origin 4.1 For purposes of this Clause "origin" means the place where the Goods were mined, grown or produced, or from which the services are supplied.

Goods are produced when, through manufacturing, processing or substantial and major assembling of components, a commercially recognized new product results that is substantially different in basic characteristics or in purpose or utility from its components.

5.0 Scope of Contract 5.1 Scope of the CONTRACT shall be as defined in the PURCHASE ORDER/CONTRACT specifications, drawings and Annexure there to.

5.2 Completeness of the EQUIPMENT shall be the responsibility of the SELLER. Any equipment, fittings and accessories which may not be specifically mentioned in the specifications or drawings, but which are usual or necessary for the satisfactory functioning of the equipment (successful operation and functioning of the



E-Tender No.: AGL/Head Office/Contract and Purchase/22/25-26/ET/22
[METERING SKIDS]
ANNUAL RATE CONTRACT (02 YEARS) FOR SUPPLY OF METERING SKIDS



EQUIPMENT being Seller's responsibility) shall be provided by SELLER without any extra cost.

- 5.3 The SELLER shall follow the best modern practices in the manufacture of high grade EQUIPMENT notwithstanding any omission in the specifications. The true intent and meaning of these documents is that SELLER shall in all respects, design, engineer, manufacture and supply the equipment in a thorough workman like manner and supply the same in prescribed time to the entire satisfaction of PURCHASER.
- 5.4 The SELLER shall furnish twelve (12) copies in English language of Technical documents, final drawings, preservation instructions, operation and maintenance manuals, test certificates, spare parts catalogues for all equipments to the PURCHASER.
- 5.5 The documents once submitted by the SELLER shall be firm and final and not subject to subsequent changes. The SELLER shall be responsible for any loss to the PURCHASER consequent to furnishing of incorrect data/drawings.
- 5.6 All dimensions and weight should be in metric system .
- 5.7 All equipment to be supplied and work to be carried out under the CONTRACT shall conform to and comply with the provisions of relevant regulations/Acts (State Government or Central Government) as may be applicable to the type of equipment/work carried out and necessary certificates shall be furnished.
- 5.8 The Seller shall provide cross sectional drawings, wherever applicable, to identify the spare part numbers and their location. The size of bearings, their make and number shall be furnished.
- 5.9 Specifications, design and drawings issued to the SELLER along with RFQ and CONTRACT are not sold or given but loaned. These remain property of PURCHASER or its assigns and are subject to recall by PURCHASER. The SELLER and his employees shall not make use of the drawings, specifications and technical information for any purpose at any time except for manufacture against the CONTRACT and shall not disclose the same to any person, firm or corporate body, without written permission of PURCHASER. All such details shall be kept confidential.
- 5.10 SELLER shall pack, protect, mark and arrange for dispatch of EQUIPMENT as per instructions given in the CONTRACT .

6.0 Standards

- 6.1 The GOODS supplied under the CONTRACT shall conform to the standards mentioned in the Technical Specifications, or such other standards which ensure equal or higher quality, and when no applicable standard is mentioned, to the authoritative



E-Tender No.: AGL/Head Office/Contract and Purchase/22/25-26/ET/22
[METERING SKIDS]
ANNUAL RATE CONTRACT (02 YEARS) FOR SUPPLY OF METERING SKIDS



standard appropriate to the GOODS' country of origin and such standards shall be the latest issued by the concerned institution.

7.0 Instructions, Direction & Correspondence

- 7.1 The materials described in the CONTRACT are to be supplied according to the standards, data sheets, tables, specifications And drawings attached there to and / or enclosed with the CONTRACT, itself and according to all conditions, both general and specific enclosed with the contract, unless any or all of them have been modified or cancelled in writing as a whole or in part.
- a. All instructions and orders to SELLER shall, excepting what is here in provided, be given by PURCHASER.
 - b. All the work shall be carried out under the direction of and to the satisfaction of PURCHASER.
 - c. All communications including technical/commercial clarifications and/or comments shall be addressed to the PURCHASER on the address mentioned in ITB.
 - d. Invoices for payment against CONTRACT shall be addressed to PURCHASER.
 - e. The CONTRACT number shall be shown on all invoices, communications, packing lists, containers and bills of lading, etc.

8.0 Contract Obligations

- 8.1 If after award of the contract, the Seller does not acknowledge the receipt of award or fails to furnish the performance guarantee Within the prescribed time limit, the PURCHASER reserves the right to cancel the contract and apply all remedies available to him under the terms and conditions of this contract.
- 8.2 Once a contract is confirmed and signed, the terms and conditions contained there in shall take precedence over the Seller's bid and all previous correspondence.

9.0 Modification In Contract

- 9.1 All modifications leading to changes in the CONTRACT with respect to technical and/or commercial aspects including terms of delivery shall be considered valid only when accepted in writing by PURCHASER by issuing amendment to the CONTRACT. Issuance of acceptance or otherwise in such cases shall not be any ground for extension of agreed delivery date and also shall not affect the performance of contract in any manner except to the extent mutually agreed through a modification of contract.
- 9.2 PURCHASER shall not be bound by any printed conditions or provisions in the Seller's Bid Forms or acknowledgment of CONTRACT, invoices, packing list and other documents which purport to impose any conditions at variance with or supplemental to CONTRACT.

10.0 Use of Contract Documents &

- 10.1 The Seller shall not, without the PURCHASER's prior written consent, disclose the CONTRACT or any provision thereof, or



E-Tender No.: AGL/Head Office/Contract and Purchase/22/25-26/ET/22
 [METERING SKIDS]
 ANNUAL RATE CONTRACT (02 YEARS) FOR SUPPLY OF METERING SKIDS



Information

any specification, plan, drawing, pattern, sample or information furnished by or on behalf of the PURCHASER in connection therewith, to any person other than a person employed by the SELLER in the performance of the CONTRACT. Disclosure to any such employed person shall be made in confidence and shall extend only so far as may be necessary for purpose of such performance.

10.2 The SELLER shall not, without the PURCHASER's prior written consent, make use of any document or information enumerated in Article 10.1. Except for purpose of performing the CONTRACT.

11.0 Patent Rights, Liability & Compliance of Regulations

11.1 SELLER hereby warrants that the use or sale of the materials delivered hereunder will not infringe claims of any patent covering such material and SELLER agrees to be responsible for and to defend at his sole expense all suits and proceedings against PURCHASER based on any such alleged patent infringement and to pay all costs, expenses and damages which PURCHASER may have to pay or incur by reason of any such suit or proceedings.

11.2 The SELLER shall indemnify the PURCHASER against all third party claims of infringement of patent, trademark or industrial design rights arising from use of the GOODS or any part thereof in the PURCHASER's country.

11.3 SELLER shall also protect and fully indemnify the PURCHASER from any claims from SELLER'S workmen/employees or their heirs, dependants, representatives, etc. or from any other person/persons or bodies/companies etc. for any acts of commissions or omission while executing the CONTRACT.

11.4 SELLER shall be responsible for compliance with all requirements under the laws and shall protect and indemnify completely the PURCHASER from any claims/penalties arising out of any infringements.

12.0 Performance Guarantee

12.1 Within 15 from the date of award of the CONTRACT, the SELLER shall furnish Performance Guarantee in the form of Bank Guarantee/irrevocable Letter of Credit to the PURCHASER, in the form provided in the Bidding Documents, for an amount equivalent to 10% of the Delivery Order value (Excluding taxes & duties).

12.2 The proceeds of Performance Guarantee shall be appropriated by the PURCHASER as compensation for any loss resulting from the Seller's failure to complete his obligations under the CONTRACT without prejudice to any of the rights or remedies the PURCHASER may be entitled to as per terms and conditions of CONTRACT. The proceeds of this Performance Guarantee shall also govern the successful performance of Goods and Services during the entire period of Contractual Warrantee/Guarantee.



E-Tender No.: AGL/Head Office/Contract and Purchase/22/25-26/ET/22
[METERING SKIDS]
ANNUAL RATE CONTRACT (02 YEARS) FOR SUPPLY OF METERING SKIDS



13 Inspection, Testing & Expediting

- 12.3 The performance guarantee shall be denominated in the currency of the CONTRACT.
- 12.4 The Performance Guarantee shall be valid for the duration of 90 days beyond the expiry of warrantee/Guarantee PURCHASER will discharge the Bank Guarantee not later than 6 months from the date of expiration of the Seller's entire obligations, including any warrantee obligations, under the CONTRACT.
- 13.1 The PURCHASER or its representative shall have the right to inspect and/or to test the GOODS to confirm their conformity to the CONTRACT specifications. The special conditions of CONTRACT and/or the Technical Specifications shall specify what inspections and tests the PURCHASER requires and where they are to be conducted. The PURCHASER shall notify the SELLER in writing the identity of any representative(s) retained for these purposes.
- 13.2 The inspections and tests may be conducted on the premises of the SELLER or his sub-contractor(s), at point of DELIVERY and/or at the GOODS' final destination, When conducted on the premises of the SELLER or his sub-contractor (s), all reasonable facilities and assistance including access to the drawings and production data shall be furnished to the inspectors at no charge to the PURCHASER.
- 13.3 Should any inspected or tested GOODS fail to conform to the specifications, the PURCHASER may reject them and the SELLER shall either replace the rejected GOODS or make all alterations necessary to meet Specifications' requirements, free of cost to the PURCHASER.
- 13.4 The PURCHASER's right to inspect, test and where necessary reject the GOODS after the GOODS' arrival in the PURCHASER's country shall in no way be limited or waived by reason of the GOODS having previously been inspected, tested and passed by the PURCHASER, or their representative prior to the GOODS shipment from the country of origin.
- 13.5 The INSPECTOR shall follow the progress of the manufacture of the GOODS under the CONTRACT to ensure that the requirements outlined in the CONTRACT are not being deviated with respect to schedule and quality.
- 13.6 SELLER shall allow the INSPECTOR to visit, during working hours, the workshops relevant for execution of the CONTRACT during the entire period of CONTRACT validity.
- 13.7 In order to enable PURCHASER's representatives to obtain entry visas in time, SELLER shall notify PURCHASER two months before assembly, testing and packing of main EQUIPMENT. If requested, SELLER shall assist PURCHASER's

Representatives in gettings visas in the shortest possible time (applicable only in case of foreign order)



E-Tender No.: AGL/Head Office/Contract and Purchase/22/25-26/ET/22
[METERING SKIDS]
ANNUAL RATE CONTRACT (02 YEARS) FOR SUPPLY OF METERING SKIDS



- 13.8 SELLER shall place at the disposal of the INSPECTOR, free of charge, all tools, instruments, and other apparatus necessary for the inspection and/or testing of the GOODS. The INSPECTOR is entitled to prohibit the use and dispatch of GOODS and/or materials, which have failed to comply with the characteristics required for the GOODS during tests and inspections.
- 13.9 SELLER shall advise in writing of any delay in the inspection program at the earliest, describing in detail the reasons for delay and the proposed corrective action.
- 13.10 ALL TESTS and trials in general, including those to be carried out for materials not manufactured by SELLER shall be witnessed by the INSPECTOR. Therefore, SELLER shall confirm to PURCHASER by fax or e-mail about the exact date of inspection with at least 30 days notice. SELLER shall specify the GOODS and quantities ready for testing and indicate whether a preliminary or final test is to be carried out.
- 13.11 If on receipt of this notice, PURCHASER should waive the right to witness the test; timely information will be given accordingly.
- 13.12 Any and all expenses incurred in connection with tests, preparation of reports and analysis made by qualified laboratories, necessary technical documents, testing documents and drawings shall be at SELLER's cost. The technical documents shall include the reference and numbers of the standards used in the construction and, wherever deemed practical by the INSPECTOR, copy of such standards.
- 13.13 Nothing in Article-13 shall in any way release the SELLER from any warrantee or other obligations under this CONTRACT.
- 13.14 Arrangements for all inspections required by Indian Statutory Authorities and as specified in technical specifications shall be made by SELLER
- 13.15 **Inspection & Rejection of Materials by consignees**
When materials are rejected by the consignee, the supplier shall be intimated with the details of such rejected materials, as well as the reasons for their rejection, also giving location where such materials are lying at the risk and cost of the contractor/supplier. The supplier will be called upon either to remove the materials or to give instructions as to their disposal within 14 days and in the case of dangerous, infected and perishable materials within 48 hours, failing which the consignee will either return the materials to the contractor freight to pay or otherwise dispose them off at the contractor's risk and cost. The PURCHASER shall also be entitled to recover handling and storage charges for the period, during which the rejected materials are not removed @ 5% of



E-Tender No.: AGL/Head Office/Contract and Purchase/22/25-26/ET/22
[METERING SKIDS]
ANNUAL RATE CONTRACT (02 YEARS) FOR SUPPLY OF METERING SKIDS



the value of materials for each month or part of a month till the rejected materials are finally disposed off.

14 Time Schedule & Progress Reporting

- 14.1 Time Schedule Network/Bar Chart
- 14.1.1 Together with the Contract confirmation, SELLER shall submit to PURCHASER, his time schedule regarding the documentation, manufacture, testing, supply, and erection and commissioning of the GOODS.
- 14.1.2 The time schedule will be in the form of a network or a bar chart clearly indicating all main or key events regarding documentation, supply of raw materials, manufacturing, testing, delivery, erection and commissioning.
- 14.1.3 The original issue and subsequent revisions of SELLER's time schedule shall be sent to PURCHASER.
- 14.1.4 The time schedule network/bar chart shall be updated at least every second month.
- 14.2 **Progress Trend Chart / Monthly Report**
- 14.2.1 SELLER shall report monthly to PURCHASER, on the progress of the execution of CONTRACT and achievement of targets set out in time bar chart.
- 14.2.2 The progress will be expressed in percentages as shown in the progress trend chart attached to the Time Schedule specification.
- 14.2.3 The first issue of the Progress Trend Chart will be forwarded together with the time bar chart along with CONTRACT confirmation.
- 14.3.1 PURCHASER's representatives shall have the right to inspect SELLER's premises with a view to evaluating the actual progress of work on the basis of SELLER's time schedule documentation.
- 14.3.2 Irrespective of such inspection, SELLER shall advise PURCHASER, at the earliest possible date of any anticipated delay in the progress.
- 14.4 Notwithstanding the above, in case progress on the execution of contract at various stages is not as per phased time schedule and is not satisfactory in the opinion of the PURCHASER which shall be conclusive or SELLER shall neglect to execute the CONTRACT with due diligence and expedition or shall contravene the provisions of the CONTRACT, PURCHASER may give notice of the same in writing to the SELLER calling upon him to make good the failure, neglect or contravention complained of. Should SELLER fail to comply with such notice within the period considered reasonable by PURCHASER, the PURCHASER shall have the option and be at liberty to take the CONTRACT wholly or in part out of the SELLER's hand and make alternative arrangements to obtain the requirements and completion of CONTRACT at the SELLER's risk and cost and



E-Tender No.: AGL/Head Office/Contract and Purchase/22/25-26/ET/22
[METERING SKIDS]
ANNUAL RATE CONTRACT (02 YEARS) FOR SUPPLY OF METERING SKIDS



recover from the SELLER, all extra cost incurred by the PURCHASER on this account. In such event PURCHASER shall not be responsible for any loss that the SELLER may incur and SELLER shall not be entitled to any gain. PURCHASER shall, in addition, have the right to encase Performance Guarantee in full or part.

15 Delivery & Documents

15.1 The SELLER in accordance with terms specified in the contract shall make delivery of the GOODS, and the goods shall remain at the risk of the SELLER until delivery has been completed.

15.2 Delivery shall be deemed to have been made:

a) In the case of FOB, CFR & CIF Contracts, when the Goods have been put on board the ship, at the specified port of loading and a clean Bill of Lading is obtained. The date of Bill of Lading shall be considered as the delivery date.

b) In case of FOT dispatch point contract (For Indian bidder), on evidence that the goods have been loaded on the carrier and a negotiable copy of the GOODS receipt obtained. The date of LR/GR shall be considered as the date of delivery.

c) In case of FOT site (for Indian bidders) on receipt of goods by PURCHASER at the designated site(s).

15.3 The delivery terms are binding and essential and consequently, no delay is allowed without the written approval of PURCHASER. Any request concerning delay will be void unless accepted by PURCHASER through a modification to the CONTRACT.

15.4 Delivery time shall include time for submission of drawings for approval, incorporation of comments, if any, and final approval of drawings by PURCHASER.

15.5 In the event of delay in delivery, Price Reduction Schedule as stipulated in Article – 26 shall apply.

15.6 The documentation, in English Language, shall be delivered in due time, in proper form and in the required number of copies as specified in the contract.

15.7 The additional copies of final drawings and instructions will be included in the package of goods, properly enveloped and protected.

15.8 The SELLER should comply with the Packing, Marking and Shipping Documentation Specifications enclosed.

16 Transit Risk Insurance

16.1 All goods supplied under the contract shall be fully insured in a freely convertible currency against loss or damage incidental to manufacture or acquisition, transportation, storage and delivery.



E-Tender No.: AGL/Head Office/Contract and Purchase/22/25-26/ET/22
[METERING SKIDS]
ANNUAL RATE CONTRACT (02 YEARS) FOR SUPPLY OF METERING SKIDS



16.2 Where delivery is on FOB or CFR basis, marine insurance shall be the responsibility of the SELLER.

Insurance Requirements:

Indigenous Bidders: Transit risk insurance from F.O.T. dispatch point onwards shall be arranged and borne by SELLER.

Foreign Bidders: Marine insurance as well as transit insurance in PURCHASER's country shall be arranged and borne by SELLER. The SELLER shall ensure that in effecting dispatch of materials, the primary responsibility of the carriers for safe movement is always retained so that the PURCHASER's interests are fully safeguarded and are in no way jeopardized.

The Seller shall furnish the cost of materials against each equipment.

17 Transportation

17.1 Where the SELLER is required under the CONTRACT to deliver the GOODS FOB, transport of the GOODS until delivery, that is, up to and including the point of putting the GOODS on board the export conveyance at the specified port of loading, shall be arranged and paid for by the SELLER and the cost thereof shall be included in the Contract price.

17.2 Where the SELLER is required under the CONTRACT to deliver the GOODS CFR or CIF, transport of the Goods to the port of discharge or such other point in the country of destination as shall be specified in the CONTRACT shall be arranged and paid for by the SELLER and the cost thereof shall be included in the Contract price.

18 Incidental Services

18.1 The Seller may be required to provide any or all of the following services:

18.3.1 Performance or supervision of onsite assembly and/or start-up of the supplied Goods:

18.3.2 Furnishing tools required for assembly and/or maintenance of the supplied Goods:

18.3.3 Performance or supervision or maintenance and/or repair of the supplied Goods, for a period of time agreed by the parties, provided that this service shall not relieve the SELLER of any warranty/guarantee obligations under the Contract.

18.3.4 Training of the PURCHASER's personnel at the SELLER's plant and/or at Site, in assembly, start-up operation, maintenance and/or repair of the supplied Goods at no extra cost. However, PURCHASER will bear boarding, lodging & personal expenses of Trainees.



E-Tender No.: AGL/Head Office/Contract and Purchase/22/25-26/ET/22
[METERING SKIDS]
ANNUAL RATE CONTRACT (02 YEARS) FOR SUPPLY OF METERING SKIDS



**19 Spare Parts,
Maintenance Tools,
Lubricants**

- 18.4 Prices charged by the SELLER for the preceding incidental services, shall not exceed the prevailing rates charged to other parties by the SELLER for similar services.
- 18.5 When required, SELLER shall depute necessary personnel for supervision and/or erection of the Equipment at site for duration to be specified by PURCHASER on mutually agreed terms. SELLER's personnel shall be available at Site within seven days for emergency action and twenty-one days for medium and long-term assistance, from the date of notice given by PURCHASER.
- 18.6 The cost of incidental services shall not be included in the quoted prices. The cost of applicable incidental services should be shown separately in the price schedules.
- 19.1 SELLER may be required to provide any or all of the following materials and notification pertaining to spare parts manufactured or distributed by the SELLER.
- 19.1.1 Such spare parts as the PURCHASER may opt to purchase from the SELLER, provided that his option shall not relieve the SELLER of any warranty obligations under the Contract, and
- 19.1.2 In the event of termination of production of the spare parts:
- i) Advance notification to the PURCHASER of the pending termination, in sufficient time to permit the PURCHASER to procure needed requirements, and
- ii) Following such termination, furnishing at no cost to the PURCHASER, the blue prints, drawings and specifications of the spare parts, if any when requested.
- 19.2 Seller shall supply item wise list with value of each item of spare parts and maintenance tools requirements, along with full details of manufacturers / vendors for such spares / maintenance tools for:
- 19.2.1 The construction, execution and commissioning.
- 19.2.2 Five (05) years operation and maintenance after commissioning of each Compressor.
- 19.3 Spare parts shall be new and of first class quality as per engineering standards/ codes, free of any defects (even concealed), deficiency in design, materials and workmanship and also shall be completely interchangeable with the corresponding parts.
- 19.4 Type and sizes of bearings shall be clearly indicated.
- 19.5 Spare parts shall be packed for long storage under tropical climatic conditions in suitable cases, clearly marked as to intended purpose.



E-Tender No.: AGL/Head Office/Contract and Purchase/22/25-26/ET/22
[METERING SKIDS]
ANNUAL RATE CONTRACT (02 YEARS) FOR SUPPLY OF METERING SKIDS



- 19.6 A list of special tools and gauges required for normal maintenance and special handling and lifting appliances, if any, for the Goods shall be submitted to Purchaser.
- 19.7 Bidders should note that if they do not comply with Clause 19.2 above, their quotation may be rejected.
- 19.8 Lubricants (not applicable)
- 19.8.1 whenever lubricants are required, SELLER shall indicate the quantity of lubricants required for the first filling, the frequency of changing, the quantity of lubricants required for the one-year's continuous operation and the types of recommended lubricants indicating the commercial name (trademark), quality and grade.
- 19.8.2 If Seller is unable to recommend specific oil, basic recommended characteristics of the lubricants shall be given.
- 19.8.3 Seller shall indicate various equivalent lubricants available in India.

20 Guarantee

- 20.1 All Goods or Materials shall be supplied strictly in accordance with the specifications, drawings, data sheets, other attachments and conditions stated in the Contract.

No deviation from such specifications or alterations or of these conditions shall be made without PURCHASER'S agreement in writing which must be obtained before any work against the order is commenced. All materials supplied by the SELLER pursuant to the Contract (irrespective of whether engineering, design data or other information has been furnished, reviewed or approved by PURCHASER) are guaranteed to be of the best quality of their respective kinds (unless otherwise specifically authorized in writing by PURCHASER) and shall be free from faulty design, workmanship and materials, and to be of sufficient size and capacity and of proper materials so as to fulfill in all respects all operating conditions, if any, specified in the Contract.

If any trouble or defect, originating with the design, material, workmanship or operating characteristics of any materials, arises at any time prior to twelve(12) months from the date of the first commercial operation of the Plant for which the materials supplied under the Contract form a part thereof, or twenty four (24) months from the date of last shipment whichever period shall first expire, and the SELLER is notified thereof, SELLER shall, at his own expense and as promptly as possible, make such alterations, repairs and replacements as may necessary to permit the materials to function in accordance with the specifications and to fulfill the foregoing guarantees.

PURCHASER may, at his option, remove such defective materials, at SELLER'S expense in which event SELLER shall, without cost to PURCHASER and as promptly as possible, furnish and install proper materials. The SELLER shall similarly guarantee repaired or replaced materials for a period of no less than twelve (12) months from the date of replacement/repair.

In the event that the materials supplied do not meet the specifications and/or not in accordance with the drawings data



**E-Tender No.: AGL/Head Office/Contract and Purchase/22/25-26/ET/22
[METERING SKIDS]
ANNUAL RATE CONTRACT (02 YEARS) FOR SUPPLY OF METERING SKIDS**



sheets or the terms of the Contract and rectification is required at site, PURCHASER shall notify the SELLER giving full details of differences. The SELLER shall attend the site within seven (7) days of receipt of such notice to meet and agree with representatives of PURCHASER, the action required to correct the deficiency. Should the SELLER fail to attend meeting at Site within the time specified above,

PURCHASER shall immediately rectify the work/materials and SELLER shall reimburse PURCHASER all costs and expenses incurred in connection with such trouble or defect.

20.2 PERFORMANCE GUARANTEE OF EQUIPMENT

20.2.1 SELLER shall guarantee that the performance of the EQUIPMENT supplied under the CONTRACT shall be strictly in conformity with the specifications and shall perform the duties specified under the CONTRACT.

20.2.2 If the SELLER fails to prove the guaranteed performance of the EQUIPMENT set forth in the specification; the SELLER shall investigate the causes and carry out necessary rectifications/modifications to achieve the guaranteed performance. In case the SELLER fails to do so within a reasonable period, the SELLER shall replace the EQUIPMENT and prove guaranteed performance of the new equipment without any extra cost to PURCHASER.

20.2.3 If the SELLER fails to prove the guarantee within a reasonable period, PURCHASER shall have the option to take over the EQUIPMENT and rectify, if possible, the EQUIPMENT to fulfill the guarantees and/or to make necessary additions to make up the deficiency at Seller's risk and cost. All expenditure incurred by the PURCHASER in this regard shall be to SELLER's account.

21 Terms of Payment 21.1 The Payment terms are specified in the Section III of Vol I of II of Bid Document.

22 Prices 22.1 Prices charged by the SELLER for Goods delivered and services performed under the CONTRACT shall not, with the exception of any price adjustments authorized by the Contract vary from the prices quoted by the SELLER in his bid.

23 Subletting & Assignment 23.1 The contractor shall not without previous consent in writing of the PURCHASER authority, sublet, transfer or assign the contract or any part thereof or interest therein or benefit or advantage thereof in any manner whatsoever. Provided, nevertheless, that any such consent shall not relieve the contractor from any obligation, duty or responsibility under the contract.

- 24 Time As Essence of Contract**
- 24.1 The time and date of delivery/completion of the GOODS / SERVICES as stipulated in the Contract shall be deemed to be the essence of the Contract.
- 25 Delays in The SELLER's Performance**
- 25.1 If the specified delivery schedule is not adhered to or the progress of manufacture or supply of the items is not satisfactory or is not in accordance with the progress schedule the PURCHASER has the right to:
- i) Hire for period of delay from elsewhere goods which in PURCHASER's opinion will meet the same purpose as the goods which are delayed and SELLER shall be liable without limitation for the hire charges; or
 - ii) Cancel the CONTRACT in whole or in part without liability for cancellation charges. In that event, PURCHASER may procure from elsewhere goods which PURCHASER's opinion would meet the same purpose as the goods for which CONTRACT is cancelled and SELLER shall be liable without limitations for the difference between the cost of such substitution and the price set forth in the CONTRACT for the goods involved; or iii) Hire the substitute goods vide (i) above and if the ordered goods continue to remain undelivered thereafter, cancel the order in part or in full vide (ii) above.
- 25.2 Any inexcusable delay by the SELLER or his sub-contractor shall render the SELLER liable, without prejudice to any other terms of the Contract, to any or all of the following sanctions: forfeiture of Contract performance guarantee, imposition of price reduction for delay in delivery and termination of the contract for default.
- 26 Price Reduction Schedule For Delayed Delivery**
- 26.1 Subject to Article -29, if the SELLER fails to deliver any or all of the GOODS or performance the services within the time period (s) specified in the CONTRACT, the PURCHASER shall, without prejudice to his other remedies under the CONTRACT, deduct from the CONTRACT PRICE, a sum calculated on the basis of the CONTRACT PRICE, including subsequent modifications.
- 26.1.1 Deductions shall apply as per following formula:
In supply contract, the portion of supply completed in all respects which can be used for commercial operation shall not be considered for applying PRS, if delivered within contractual delivery period. The remaining supplies which are completed beyond the contractual delivery shall attract the price reduction schedule @0.5% per week or part thereof of the delayed delivery value maximum up to 5% of total Purchase Order value. The total value of PO considered for applying PRS shall be excluding of all Taxes and Duties.
- 26.2 In case of delay in delivery on the part of Seller, the invoice/document value shall be reduced proportionately for the delay and payment shall be released accordingly.
- 26.3 In the event the invoice value is not reduced proportionately for the delay, the PURCHASER may deduct the amount so payable



**E-Tender No.: AGL/Head Office/Contract and Purchase/22/25-26/ET/22
[METERING SKIDS]
ANNUAL RATE CONTRACT (02 YEARS) FOR SUPPLY OF METERING SKIDS**



In the event the invoice value is not reduced proportionately for the delay, the PURCHASER may deduct the amount so payable to SELLER, from any amount falling due to the SELLER or by recovery against the Performance Guarantee.

Both SELLER and PURCHASER agree that the above percentages of price reduction are genuine pre estimates of the loss/damage which the PURCHASER would have suffered on account of delay/breach on the part of the SELLER and the said amount will be payable on demand without there being any proof of the actual loss/or damage caused by such breach/delay. A decision of the PURCHASER in the matter of applicability of price reduction shall be final and binding.

27 Rejections, Removal of Rejected Equipment & Replacement

- 27.1 Preliminary inspection at SELLER's works by INSPECTOR shall not prejudice PURCHASER's claim for rejection of the EQUIPMENT on final inspection at SITE or claims under warranty provisions.
- 27.2 If the EQUIPMENTS are not of specification or fail to perform specified duties or are otherwise not satisfactory the PURCHASER shall be entitled to reject the EQUIPMENT/MATERIAL or part thereof and ask free replacement within reasonable time failing which obtain his requirements from elsewhere at SELLER's cost and risk.
- 27.3 Nothing in this clause shall be deemed to deprive the PURCHASER AND/OR AFFECT ANY rights under the Contract which it may otherwise have in respect of such defects or deficiencies or in any way relieve the SELLER of his obligations under the Contract.
- 27.4 EQUIPMENT rejected by the PURCHASER shall be removed by the SELLER at his cost within 14 days of notice after repaying the amounts received against the SUPPLY. The PURCHASER shall in no way be responsible for any deterioration or damage to the EQUIPMENT under any circumstances whatsoever.
- 27.5 In case of rejection of EQUIPMENT, PURCHASER shall have the right to recover the amounts, if any, from any of CONTRACTOR'S invoices pending with PURCHASER or by alternative method(s).

28 Termination of Contract

- 28.1 Termination for Default
 - 28.1.1 The PURCHASER may, without prejudice to any other remedy for breach of CONTRACT, by written notice of default sent to the SELLER, terminate the CONTRACT in whole or in part:
 - A) If the SELLER fails to deliver any or all of the GOODS within the time period(s) specified in the CONTRACT; or
 - B) If the SELLER fails to perform any other obligation(s) under the CONTRACT, and



E-Tender No.: AGL/Head Office/Contract and Purchase/22/25-26/ET/22
[METERING SKIDS]
ANNUAL RATE CONTRACT (02 YEARS) FOR SUPPLY OF METERING SKIDS



C) If the SELLER, in either of the above circumstances, does not cure his failure within a period of 30 days (or such longer period as the PURCHASER may authorize in writing) after receipt of the default notice from the PURCHASER.

28.1.2 In the event the PURCHASER terminates the CONTRACT in whole or in part, pursuant to Article 28.1.1, the PURCHASER may procure, upon such terms and in such manner, as it deems appropriate, goods similar to those undelivered and the SELLER shall be liable to the PURCHASER for any excess costs for such similar GOODS. However, the SELLER shall continue performance of the CONTRACT to the extent not terminated.

28.1.3 In case of termination of CONTRACT herein set forth (under clause 28) except under conditions of Force Majeure and termination after expiry of contract, the VENDOR shall be put under holiday [i.e. neither any enquiry will be issued to the party by AGL against any type of tender nor their offer will be considered by AGL against any ongoing tender (s) where contract between AGL and that particular VENDOR (as a bidder) has not been finalized] for three years from the date of termination by AGL to such VENDOR.

28.2 Termination for Insolvency

28.2.1 The PURCHASER, may at any time, terminate the CONTRACT by giving written notice to the SELLER, without compensation to the SELLER, if the SELLER becomes bankrupt or otherwise insolvent, provided that such termination will not prejudice or affect any right of action or remedy which has accrued or will accrue thereafter to the PURCHASER.

28.3 Termination for Convenience

28.3.1 The PURCHASER may, by written notice sent to the SELLER, terminate the CONTRACT, in whole or part, at any time for his convenience. The notice of termination shall specify that termination is for the PURCHASER's convenience, the extent to which performance of work under the CONTRACT is terminated and the date upon which such termination becomes effective.

28.3.2 The GOODS those are complete and ready for shipment within 30 days after the SELLER's receipt of notice of termination at the CONTRACT terms and prices. For the remaining GOODS, the PURCHASER may opt:

- a) To have any portion completed and delivered at the CONTRACT terms and prices, and /or
- b) To cancel the remainder and pay to the SELLER an agreed amount for partially completed GOODS and for materials and parts previously procured by the SELLER.

29 Force Majeure

29.1 Shall mean and be limited to the following:



E-Tender No.: AGL/Head Office/Contract and Purchase/22/25-26/ET/22
[METERING SKIDS]
ANNUAL RATE CONTRACT (02 YEARS) FOR SUPPLY OF METERING SKIDS



- a) War/hostilities
- b) Riot or Civil commotion
- c) Earthquake, flood, tempest, lightening or other natural physical disaster.
- d) Restrictions imposed by the Government or other Statutory bodies, which prevents or delays the execution of the Contract by the SELLER. The SELLER shall advise PURCHASER by a registered letter duly certified by the local Chamber of Commerce or statutory authorities, the beginning and end of the above causes of delay within seven (7) days of the occurrence and cessation of such Force Majeure Conditions. In the event of delay lasting over one month, if arising out of causes of Force Majeure, PURCHASER reserves the right to cancel the Contract and the provisions governing termination stated under Article 28.0 shall apply.

For delays arising out of Force Majeure, the SELLER shall not claim extension in completion date for a period exceeding the period of delay attributable to the causes of Force Majeure and neither PURCHASER nor SELLER shall be liable to pay extra costs provided it is mutually established that Force Majeure Conditions did actually exist.

SELLER shall categorically specify the extent of Force Majeure Conditions prevalent in their works at the time of submitting their bid and whether the same have been taken into consideration or not in their quotations. In the event of any force majored cause, the SELLER or the PURCHASER shall not be liable for delays in performing their obligations under this order and the delivery dates will be extended to the SELLER without being subject to price reduction for delayed deliveries, as stated elsewhere.

30 Resolution of Disputes / Arbitration

- 30.1 The PURCHASER and the SELLER shall make every effort to resolve amicably by direct informal negotiations any disagreement or dispute arising between them under or in connection with the contract.
- 30.2 If, after thirty days from the commencement of such informal negotiations, the PURCHASER and the SELLER have been unable to resolve amicably a Contract dispute, either party may require that the dispute be referred for resolution to the formal mechanism as specified hereunder.
- 30.3 Legal Construction

The Contract shall be, in all respects be construed and operated as an Indian Contract and in accordance with Indian Laws as in force for the time being and is subject to and referred to the Indore Court of Law.
- 30.4 Arbitration



E-Tender No.: AGL/Head Office/Contract and Purchase/22/25-26/ET/22
[METERING SKIDS]
ANNUAL RATE CONTRACT (02 YEARS) FOR SUPPLY OF METERING SKIDS



All disputes, controversies, or claims between the parties (except in matters where the decision of the Engineer-in-Charge is deemed to be final and binding), which cannot be mutually resolved within a reasonable time, shall be referred to Arbitration by a sole arbitrator.

The PURCHASER shall suggest a panel of three independent and distinguished persons to the SELLER to select any one among them to act as the sole Arbitrator.

In the event of failure of the SELLER to select the Sole Arbitrator within 30 days from the receipt of the communication suggesting the panel of arbitrators, the right of selection of Sole Arbitrator by the other party shall stand forfeited and the PURCHASER shall have discretion to proceed with the appointment of the Sole Arbitrator. The decision of the PURCHASER on the appointment of Sole Arbitrator shall be final and binding on the parties.

The award of the Sole Arbitrator shall be final and binding on the parties and unless directed/awarded otherwise by the Sole Arbitrator, the cost of arbitration proceedings shall be shared equally by the parties. The arbitration proceeding shall be in English language and the venue shall be at Indore, India.

Subject to the above, the provisions of (Indian) Arbitration & Conciliation Act, 1996 and the rules framed thereunder shall be applicable. All matters relating to this contract are subject to the exclusive jurisdiction of the Courts situated in Indore.

Seller may please note that the Arbitration & Conciliation Act 1996 was enacted by the Indian Parliament and is based on United nations Commission on International Trade Law (UNCITRAL model law), which were prepared after extensive consultation with Arbitral Institutions and centres of International Commercial Arbitration. The United Nations General Assembly vide resolution 31/98 adopted the UNCITRAL Arbitration rules on 15 December 1996.

The WORK under the CONTRACT shall, however, continue during the Arbitration proceedings and no payment due or payable to the Seller shall be withheld on account of such proceedings.

31 Governing Language

31.1 The Contract shall be written in English language as specified by the PURCHASER in the Instruction to Bidders. All literature, correspondence and other documents pertaining to the Contract which are exchanged by the parties shall be written in English language. Printed literature in other language shall only be considered, if it is accompanied by an English translation. For the purposes of interpretation, English translation shall govern and be binding on all parties.

32 Notices

32.1 Any notice given by one party to the other pursuant to the Contract



E-Tender No.: AGL/Head Office/Contract and Purchase/22/25-26/ET/22
[METERING SKIDS]
ANNUAL RATE CONTRACT (02 YEARS) FOR SUPPLY OF METERING SKIDS



shall be sent in writing or by telegram or fax, telex/cable confirmed in writing.

32.2 A notice shall be effective when delivered or on the notice's effective date, whichever is later.

33 Taxes & Duties

33.1 A foreign SELLER shall be entirely responsible for all taxes, stamp duties, license fees, and other such levies imposed outside the PURCHASER's country.

33.2 A domestic SELLER shall be entirely responsible for all taxes, duties, licence fees etc. incurred until the delivery of the contracted goods to the PURCHASER. However, GST (IGST, CGST, SGST, UGST) on finished products shall be reimbursed by PURCHASER upon submission of proof of payment.

33.3 Customs duty payable in India for imported goods ordered by PURCHASER on foreign SELLER shall be borne and paid by THE SELLER.

33.4 Any income tax payable in respect of supervisory services rendered by foreign SELLER under the Contract shall be as per the Indian Income Tax Act and shall be borne by SELLER. It is up to the bidder/seller to ascertain the amount of these taxes and to include them in his bid price.

34 Books & Records

34.1 SELLER shall maintain adequate books and records in connection with Contract and shall make them available for inspection and audit by PURCHASER or their authorized agents or representatives during the terms of Contract until expiry of the performance guarantee. Fixed price (lump sum or unit price) Contract will not be subject to audit as to cost except for cost reimbursable items, such as escalation and termination claims, transportation and comparable requirements.

35 Permits & Certificates

35.1 SELLER shall procure, at his expense, all necessary permits, certificates and licenses required by virtue of all applicable laws, regulations, ordinances and other rules in effect at the place where any of the work is to be performed, and SELLER further agrees to hold PURCHASER harmless from liability or penalty which might be imposed by reason of any asserted or established violation of such laws, regulations, ordinances or other rules. PURCHASER will provide necessary permits for SELLER's personnel to undertake any work in India in connection with Contract.

36 General

36.1 In the event that terms and conditions stipulated in the General Conditions of Contract should deviate from terms and conditions stipulated in the Contract, the latter shall prevail.

36.2 Losses due to non-compliance of Instructions Losses or damages occurring to the PURCHASER owing to the SELLER's failure to adhere to any of the instructions given by the



E-Tender No.: AGL/Head Office/Contract and Purchase/22/25-26/ET/22
[METERING SKIDS]
ANNUAL RATE CONTRACT (02 YEARS) FOR SUPPLY OF METERING SKIDS



- PURCHASER in connection with the contract execution shall be recoverable from the SELLER.
- 36.3 Recovery of sums due
All costs, damages or expenses which the PURCHASER may have paid, for which under the CONTRACT SELLER is liable, may be recovered by the PURCHASER (he is hereby irrevocably authorized to do so) from any money due to or becoming due to the SELLER under this Contract or other Contracts and/or may be recovered by action at law or otherwise. If the same due to the SELLER be not sufficient to recover the recoverable amount, the SELLER shall pay to the PURCHASER, on demand, the balance amount.
- 36.4 Payments, etc. not to affect rights of the PURCHASER No sum paid on account by the PURCHASER nor any extension of the date for completion granted by the PURCHASER shall affect or prejudice the rights of the PURCHASER against the SELLER or relieve the SELLER of his obligation for the due fulfillment of the CONTRACT.
- 36.5 Cut-off Dates
No claims or correspondence on this Contract shall be entertained by the PURCHASER after 90 days after expiry of the performance guarantee (from the date of final extension, if any)
- 36.6 Paragraph heading
The paragraph heading in these conditions shall not affect the construction thereof.
- 37 Import License** 37.1 No import license is required for the imports covered under this document.
- 38 Fall Clause** 38.1 The price charged for the materials supplied under the order by the supplier shall in no event exceed the lowest price at which the supplier or his agent/principal/dealer, as the case may be, sells the materials of identical description to any persons/organizations including the PURCHASER or any department of the Central Govt. or any Deptt. Of a State Govt. or any Statutory Undertaking of the Central or State Govt. as the case may be, during the currency of the order.
- 38.2 If at any time during the said period, the supplier or his Agent /principal /dealer, as the case may be, reduces the sale price, sells or offers to sell such materials to any persons/organizations including the PURCHASER or any Deptt. Of Central Govt. or State Govt. as the case may be, at a price lower than the price chargeable under the order, he shall forthwith notify such reduction or sale or offer of sale to the PURCHASE Authority who has issued this order and the price payable under the order for the materials supplied after the date of coming into force of



**E-Tender No.: AGL/Head Office/Contract and Purchase/22/25-26/ET/22
[METERING SKIDS]
ANNUAL RATE CONTRACT (02 YEARS) FOR SUPPLY OF METERING SKIDS**



such reduction or sale or offer of sale shall stand correspondingly reduced.

The above stipulation will, however, not apply to:

- a) Exports by the Contractor/Supplier or
- b) Sale of goods as original equipment at prices lower than the prices charged for normal replacement
- c) Sale of goods such as drugs, which have expiry dates.

38.3 The supplier shall furnish the following certificate to the concerned Paying Authority along with each bill for payment for supplies made against this order: -

“I/We certify that there has been no reduction in sale price of the Items /goods /materials of description identical to those supplied to the AGL under the order herein and such items/goods/materials have not been offered / sold by me/us to any person/organizations including the Purchaser or any Deptt. Of Central Govt. or any Deptt. of State Govt. or any Statutory Undertaking of the Central or State Govt. as the case may be up to the date of bill/during the currency of the order whichever is later, at a price lower than the price charged to the AGL under the order.”

Such a certificate shall be obtained, except for quantity of Items /goods /materials categories under sub-clause (a), (b) & (c) of sub- Para 38.2 above, of which details shall be furnished by the supplier.

39 Publicity & Advertising

39.1 Seller shall not without the written permission of PURCHASER make a reference to PURCHASER or any Company affiliated with PURCHASER or to the destination or the description of goods or services supplied under the contract in any publication, publicity or advertising media.

40 Repeat Order

40.1 PURCHASER reserves the right, within 6 months of order to place repeat order up to 100% of the total order value without any change in unit price or other terms and conditions.

41 Limitation of Liability

41.1 Notwithstanding anything contrary contained herein, the aggregate total liability of SELLER under the Agreement or otherwise shall be limited to 100% of Agreement / Order price.

However, neither party shall be liable to the other party for any indirect and consequential damages, loss of profits or loss of production.

42 General Terms & Conditions of Works Contract

1. SUBMISSION OF TENDER

A. The contractor shall make all arrangements at his own cost to transport the required materials outside and inside the working places and leaving the premises in a neat and tidy condition after completion of the job to the satisfaction of Owner. All materials except those agreed to be supplied by the Owner shall be supplied by the contractor at his own cost and the rates quoted by the Contractor should be inclusive of all royalties, rents, taxes, duties, statutory levies, if any, etc.

2. STATUTORY LEVIES

A. The Contractor accepts full and exclusive liability for the payment of any and all taxes, duties, cess, levies and statutory payments payable under all or any of the statutes. Variations of taxes and duties arising out of the amendments to the Central / State enactments, in respect of sale of goods / services covered under this bid shall be to AGL's account, so long as:

- They relate to the period after the opening of the price bid, but before the contracted completion period (excluding permitted extensions due to delay on account of the contractors, if any) or the actual completion period, whichever is earlier; and
- The vendor furnishes documentary evidence of incurrence of such variations, in addition to the invoices/documents for claiming Input Tax credit, wherever applicable.

B. The rates quoted should be inclusive of all taxes. However, wherever the tax is to be deducted at source, the same will be deducted from the bills of the Contractor and paid to the concerned authorities. The proof of such payments of tax will be furnished to the contractor.

The Vendor shall comply with all the provisions of the GST Act / Rules / requirements like providing of tax invoices, payment of taxes to the authorities within the due dates, filing of returns within the due dates etc. to enable AGL to take Input Tax Credit. In case of imports, vendor shall provide import documents and invoice fulfilling the requirement of Customs Act and Rules. Vendor will be fully responsible for complying with the Customs provisions to enable AGL to take input Tax Credit.

In case, AGL is not able to take Input Tax Credit due to any noncompliance/default/negligence of the seller of goods / service provider, the same shall be recovered from the pending bills/dues (including security deposit, BG etc.).

Vendor shall be responsible to indemnify the AGL for any loss, direct or implied, accrued to the AGL on account of supplier/service provider failure to discharge his statutory liabilities like paying taxes on time, filing appropriate returns within the prescribed time etc.

3. Anti - Profiteering Clause

GST Act. anti-profiteering provisions mandates that any reduction in tax rates or benefits of input tax credits be passed on to the consumer by way of commensurate reduction in prices. Vendors to take note of the same and pass such benefits while quoting their price.

43 General Terms & Conditions For Supply

1. PRICE

- a. Unless otherwise agreed to in the terms of the Purchase Order, the price shall be firm and not subject to escalation for any reason whatsoever till the execution of entire order, even though it might be necessary for the order execution to take longer than the delivery period specified in the order.
- b. Price shall be exclusive of GST (CGST, SGST, IGST as applicable), Customs Duty and applicable cess, which are leviable by law on sale of finished goods to AGL. The nature and extent of such levies shall be shown separately.

2. TAXES & DUTIES:

- a. GST (CGST, SGST, IGST as applicable), Customs Duty and applicable Cess as applicable shall be reimbursed for the materials consigned to AGL as per limits indicated in the offer against documentary evidence to be furnished by the Supplier. AGL shall pay only those taxes, duties and levies as indicated by Supplier at the time of bid submission/as agreed subsequently (prior to opening of priced bids). Taxes / Duties and/or Levies not indicated by supplier in Bid, but payable, shall be to Supplier's account. In case of any increase/decrease applicable in GST (CGST, SGST, IGST as applicable) Custom Duty and applicable Cess indicated with reference to limits mentioned in the offer / bid or new taxes / duties / levies imposed by the Indian Government through Gazette notification after the date of submission of last Price bid but prior to Contractual Delivery Date, the AGL shall reimburse/adjust the increase/decrease in taxes & duties on satisfactory supporting documents.
- b. Supplier shall be responsible for availing all applicable concessions in taxes, duties, levies etc. as per terms of Purchase Order. Any loss, direct or implied, accrued to AGL on account of supplier's failure to avail concessions shall be borne by Supplier.

3. CUSTOMS DUTY (CD) VARIATION

- a. The prices mentioned in offer are subject to Customs Duty (CD) variation. In case of any increase in rates of Customs Duty, IGST and applicable Cess by the Indian Government through Gazette notification after the submission of last priced offer but within the time schedule for import of materials, as mentioned. AGL shall reimburse the increase in taxes & duties at actuals against satisfactory supporting documents.
- b. All downward variations in the rates of all such duties shall be to AGL's account and same shall be calculated on actual CIF value of imported materials. Supplier shall submit all relevant documents to AGL for the proof of duty paid by them within one month from the date of Bill of Entry (BOE).
- c. Custom Duty variation shall be paid by AGL up to the limit of maximum CIF value of imported components as indicated in the offer.
- d. Rate of Custom Duty along with tariff number considered by Supplier in the prices shall be indicated in the offer.

The Vendor shall comply with all the provisions of the GST Act / Rules / requirements like providing of tax invoices, payment of taxes to the authorities within the due dates, filing of returns within the due dates etc. to enable AGL to take Input Tax Credit. In case of imports, vendor shall provide import documents and invoice fulfilling the requirement of Customs Act and Rules. Vendor will be fully responsible for complying with the Customs provisions to enable AGL to take Input Tax Credit.

In case, AGL is not able to take Input Tax Credit due to any noncompliance / default / negligence of the seller of goods / service provider, the same shall be recovered from the pending bills/dues (including security deposit, BG etc.).

Vendor shall be responsible to indemnify the AGL for any loss, direct or implied, accrued to the AGL on account of supplier/service provider failure to discharge his statutory liabilities like paying taxes on time, filing appropriate returns within the prescribed time etc.

4. Anti - Profiteering Clause

GST Act. Anti-profiteering provisions mandates that any reduction in tax rates or benefits of input tax credits be passed on to the consumer by way of commensurate reduction in prices. Vendors to take note of the same and pass such benefits while quoting their price

44 General Terms & Conditions of contract for Consultancy Services

A. STATUTORY LEVIES, TAXES AND DUTIES

- 1 The Consulting-firm accepts full and exclusive liability for payment of all taxes under any Statute as applicable in performance of the service and quoted price should include all such taxes & duties, if applicable which will be quoted separately.
- 2 All Domestic Consulting-firm's should have GST registration and to provide a copy of such registration certificate and classification of service along with bid document unless exempted for which necessary document support is provided.
- 3 In case of Foreign Consultants, where the service is provided from the establishment within India, clause 1 and as applicable to Indian Bidder in 2 would apply. Where the service is provided from the establishment situated outside India, GST tax will be paid by the Owner as recipient of service as per existing Act & Rules.
- 4 The Owner may claim Input Tax credit. The bidder should quote GST separately. Bidder should provide tax invoice as per the act / rules to enable owner to claim Input Tax Credit.
- 5 All taxes & duties payable outside India in respect of performance of the contract shall be borne & paid by the Consultant. The Consulting-firm shall bear and pay all the liabilities in respect of non-observance of all legal formalities as per various statutory provisions.
- 6 Unless specifically provided for in the tender documents or any Special Conditions, Variations of taxes i.e.GST quoted in price bid arising out of the amendments to the Central / State enactment, in respect of services covered under this bid shall be to Owner's account, so long as:



E-Tender No.: AGL/Head Office/Contract and Purchase/22/25-26/ET/22
[METERING SKIDS]
ANNUAL RATE CONTRACT (02 YEARS) FOR SUPPLY OF METERING SKIDS



- (i) **They relate to the period from the date / time of opening of the bid, but before the contractual completion period** (excluding permitted extensions due to delay on account of the Consulting-firm, if any) or the actual completion period, whichever is earlier; and
 - (ii) The consultant furnishes documentary evidence of incurrence of such variations, in addition to the invoices and filing required returns for claiming Input Tax credit, wherever applicable.
- 7 The Consultant shall bear and pay all liabilities in respect of statutory variations in taxes and duties and imposition of new taxes and duties that may be imposed after the delivery and payment schedule execution dates, as originally stipulated, in case the delivery dates are extended due to reasons attributable to Consultant.

The Vendor shall comply with all the provisions of the GST Act /Rules /requirements like providing of tax invoices, payment of taxes to the authorities within the due dates, filing of returns within the due dates etc. to enable AGL to take Input Tax Credit.

In case, AGL is not able to take Input Tax Credit due to any noncompliance/default/negligence of the seller of goods / service provider, the same shall be recovered from the pending bills/dues (including security deposit, BG etc.).

Vendor shall be responsible to indemnify the AGL for any loss, direct or implied, accrued to the AGL on account of supplier/service provider failure to discharge his statutory liabilities like paying taxes on time, filing appropriate returns within the prescribed time etc.



E-Tender No.: AGL/Head Office/Contract and Purchase/22/25-26/ET/22
[METERING SKIDS]
ANNUAL RATE CONTRACT (02 YEARS) FOR SUPPLY OF METERING SKIDS



SECTION - VI FORMS AND FORMATS

INDEX

Sr. No.	Form	Description
1.	Form-1	Bidder's General Information
2.	Form-2	Bid Form
3.	Form-3	List of Enclosures
4.	Form-3A	Annual Turnover
5.	Form-3B	Financial Situation
6.	Form-4	Bank Guarantee for EMD / Bid Security
7.	Form-5	Letter of Authority in Bidder's Letterhead
8.	Form-6	No Deviation Confirmation in Bidder's Letterhead
9.	Form-8	Details of Similar Work / Supply During Past 5 years
10.	Form-9	Proforma of bank Guarantee for Contract Performance
11.	Form-10	Certificate of Non-Involvement of Agent in Bidder's Letterhead
12.	Form-11	Check List
13.	Form-12	Declaration in Bidder's Letterhead
14.	Form – 13	Declaration for change in Tender No



E-Tender No.: AGL/Head Office/Contract and Purchase/22/25-26/ET/22
 [METERING SKIDS]
 ANNUAL RATE CONTRACT (02 YEARS) FOR SUPPLY OF METERING SKIDS



FORM - 1
BIDDER'S GENERAL INFORMATION

To

Aavantika Gas Limited

202 – B, 2nd Floor, NRK Business Park,
 Vijay Nagar Square, A.B. Road,
 Indore (M.P), Pin – 452010

1-1 Bidder Name: _____

1-2 Number of Years in Operation: _____

1-3 Address of Registered Office: _____

City _____ District _____
 State _____ PIN/ZIP _____

1-4 Operation Address

if different from above:

City _____ District _____
 State _____ PIN/ZIP _____

1-5 Telephone Number: _____

(Country Code) (Area Code) (Telephone Number)

1-6 E-mail address: _____

1-7 Website: _____

1-8 Fax Number: _____

(Country Code) (Area Code) (Telephone Number)

1-9 ISO Certification, if any {If yes, please furnish details}

1-10 Bid Currency _____

1-11 Port of shipment / Dispatch Point _____

1-12 Whether Supplier / Manufacturer _____

Dealer/Trader/Contractor



E-Tender No.: AGL/Head Office/Contract and Purchase/22/25-26/ET/22
[METERING SKIDS]
ANNUAL RATE CONTRACT (02 YEARS) FOR SUPPLY OF METERING SKIDS



- 1-13 Type of Material Supplies : _____
- 1-14 Banker's Name : _____
- 1-15 Branch : _____
- 1-16 Branch Code : _____
- 1-17 Bank account number : _____
- 1-18 GSTN No.: _____
- 1-19 State / UT.: _____
- 1-20 PAN No. : _____
- 1-21 Whether SSI Registrant Or not : _____
- 1-22 EPF No. _____

(SIGNATURE OF BIDDER WITH SEAL)

NOTE:

- Bidders have to submit the supporting document confirming the above registrations.**



**E-Tender No.: AGL/Head Office/Contract and Purchase/22/25-26/ET/22
[METERING SKIDS]
ANNUAL RATE CONTRACT (02 YEARS) FOR SUPPLY OF METERING SKIDS**



**FORM – 2
BID FORM**

To
Aavantika Gas Limited
202 – B, 2nd Floor, NRK Business Park,
Vijay Nagar Square, A.B. Road,
Indore (M.P), Pin – 452010
Dear Sir,

After examining/reviewing the Bidding Documents for supply of 1200 SCMh CNG Compressor, including technical specifications, drawings, General and Special Conditions of Contract and Price schedule etc. the receipt of which is hereby duly acknowledged, we, the undersigned, are pleased to bid to execute the whole of the Job for the item in conformity with, the said Bidding Documents, including Corrigendum / Addenda Nos.....

We confirm that this bid is valid for a period of Four (4) months from the date of opening of Techno-Commercial Bid, and it shall remain binding upon us and may be accepted by any time before the expiration of that period.

If our bid is accepted, we will provide the performance guarantee as per clause no 39 of GCC, for the due performance within fifteen days of such award. Until a final Contract is prepared and executed, the bid together with your written acceptance thereof in your notification of award shall constitute a binding Contract between us.

We understand that Bidding Document is not exhaustive and any action and activity not mentioned in Bidding Documents but may be inferred to be included to meet the intent of the Bid Documents shall be deemed to be mentioned in Bidding Documents unless otherwise specifically excluded and we confirm to perform for fulfillment of Agreement and completeness of the Work in all respects within the time frame and agreed price.

We understand that you are not bound to accept the lowest priced or any bid that you may receive.

SEAL AND SIGNATURE
DATE:

Duly authorized to sign bid for and on behalf of

(SIGNATURE OF WITNESS)

WITNESS NAME:

ADDRESS:



E-Tender No.: AGL/Head Office/Contract and Purchase/22/25-26/ET/22
[METERING SKIDS]
ANNUAL RATE CONTRACT (02 YEARS) FOR SUPPLY OF METERING SKIDS



**FORM – 3 A
ANNUAL TURNOVER**

Bidder must fill in this form

Annual Turnover data for the last 3 years:

Year		Amount (in INR)
Year 1:		
Year 2:		
Year 3:		

1. The information supplied should be the Annual Turnover of the bidder
2. A brief note should be appended describing thereby details of turnover as per audited results.

SEAL AND SIGNATURE OF THE BIDDER

**FORM – 3 B
FINANCIAL STATUS**

Bidder must fill this form

FINANCIAL DATA FOR LAST AUDITED FINANCIAL YEAR

Description	For the year of
	Amount (in INR)
1. Current assets	
2. Current Liabilities (including secured and un-secured short term loans & working capital loans)	
3. Working Capital (Current Assets-Current liabilities)	
4. Net Worth Owners funds (Paid up share capital and Free Reserves & Surplus) (NW)	

- Attached are copies of the audited balance sheets, including all related notes and income statement for the last Audited Financial year, as indicated above, complying with the following conditions.
 - All such documents reflect the financial situation of the bidder
 - Historic financial statements must be audited by a certified accountant.
 - Historic financial statements must be complete, including all notes to the financial statements.
 - Historic financial statements must correspond to accounting periods already completed and audited (no statement for partial periods shall be requested or accepted)

SEAL AND SIGNATURE OF BIDDER



**E-Tender No.: AGL/Head Office/Contract and Purchase/22/25-26/ET/22
[METERING SKIDS]
ANNUAL RATE CONTRACT (02 YEARS) FOR SUPPLY OF METERING SKIDS**



**FORM – 3 C
FORMAT FOR CERTIFICATE FROM BANK IF BIDDER'S WORKING
CAPITAL IS INADEQUATE / NEGATIVE**

(To be provided on Bank's letter head)

To,
M/s Aavantika Gas Limited

Date:

Dear Sir,

This is to certify that M/s----- (name of the Bidder with address) (hereinafter referred to as Customer) is an existing Customer of our Bank.

The Customer has informed that they wish to bid for Aavantika Gas Limited Tender No.-----dated----- for----- (Name of the supply/work/services/consultancy) and as per the terms of said Tender Document they have to furnish a certificate from their Bank confirming the availability of line of credit.

According M/s----- (name of the Bank with address) confirms availability of line of credit to M/s--- (name of the Bidder) for at least an amount of Rs.....

It is also confirmed that the net worth of the Bank is more than Rs. 100 Crores (or Equivalent USD) and the undersigned is authorized to issue this certificate.

Yours truly,

For.....(Name & address of Bank)

(Authorized signatory)
Name of the signatory:
Designation:
Email Id:
Contact No.:
Stamp:

Note:
This Declaration Letter for line of credit shall be from single bank only. Letters from multiple banks shall not be applicable. However, banking syndicate will be acceptable wherein a group of banks can jointly provide line of credit to the bidder.



**E-Tender No.: AGL/Head Office/Contract and Purchase/22/25-26/ET/22
[METERING SKIDS]
ANNUAL RATE CONTRACT (02 YEARS) FOR SUPPLY OF METERING SKIDS**



**FORM - 4
PROFORMA FOR BANK GUARANTEE FOR EARNEST MONEY DEPOSIT/ BID SECURITY
(To be stamped in accordance with the Stamp Act)**

Ref.....

Bank Guarantee No.....
Date.....

To
Aavantika Gas Limited,
Second Floor 202-B, NRK Business Park,
Vijay Nagar Square, AB Road,
Indore-452010,

Dear Sir(s),
In accordance with Invitation for Bid under your reference No. _____
M/s. _____ having their Registered / Head Office at
_____ (hereinafter called the Tenderer) wish to participate in the
said bidding for _____.

As an irrevocable Bank Guarantee against Earnest Money for the amount of _____ is required to be submitted by the Bidder as a condition precedent for participation in the said bidding which amount is liable to be forfeited on the happening of any contingencies mentioned in the Bidding Document.

We, the _____ Bank at _____
having our Head Office _____
(Local Address) guarantee and undertake to pay immediately on demand without any recourse to the bidder by AAVANTIKA GAS Ltd., the amount _____
_____ without any reservation, protest, demur and recourse. Any such demand made by AAVANTIKA GAS Ltd., shall be conclusive and binding on us irrespective of any dispute or difference raised by the Bidder.

This guarantee shall be irrevocable and shall remain valid upto _____ [this date should be valid for 2 months in excess of bid validity]. If any further extension of this guarantee is required, the same shall be extended to such required period on receiving instructions from M/s. _____ whose behalf this guarantee is issued.

In witness whereof the Bank, through its authorized officer, has set its hand and stamp on this _____ day of _____ 200__ at _____.

WITNESS:

(SIGNATURE)
(NAME)

(SIGNATURE)
(NAME)
Designation with Bank Stamp

(OFFICIAL ADDRESS)

Attorney as per Power of Attorney
No. _____
Date: _____



E-Tender No.: AGL/Head Office/Contract and Purchase/22/25-26/ET/22
[METERING SKIDS]
ANNUAL RATE CONTRACT (02 YEARS) FOR SUPPLY OF METERING SKIDS



INSTRUCTIONS FOR FURNISHING BANK GUARANTEE FOR EMD/BID SECURITY

1. The Bank Guarantee by bidders will be given on non-judicial stamp paper as per stamp duty applicable. The non-judicial stamp paper should be in the name of the issuing bank. In case of foreign bank, the said banks guarantee to be issued by its correspondent bank in India on requisite non-judicial stamp paper.
2. The expiry date as mentioned in bid document should be arrived at by adding 2 months to the date of expiry of the bid validity unless otherwise specified in the Bidding Documents.
3. The bank guarantee by bidders will be given from bank as specified in ITB
4. A letter from the issuing bank of the requisite Bank Guarantee confirming that said bank guarantee /all future communication relating to the Bank Guarantee shall be forwarded to the Employer at its address as mentioned at ITB.
5. Bidders must indicate the full postal address of the bank along with the bank's e-mail/ Fax no. From where the earnest money bond has been issued.
6. If a bank guarantee is issued by a commercial bank, then a letter to Employer confirming its net worth is more than Rs. 1,000,000,000/- (Rupees one hundred crore) or equivalent along with documentary evidence.



E-Tender No.: AGL/Head Office/Contract and Purchase/22/25-26/ET/22
 [METERING SKIDS]
 ANNUAL RATE CONTRACT (02 YEARS) FOR SUPPLY OF METERING SKIDS



FORM-5

**LETTER OF AUTHORITY
 PROFORMA FOR LETTER OF AUTHORITY FOR ATTENDING AND SUBSEQUENT
 NEGOTIATIONS / CONFERENCES**

No.

Date:

Aavantika Gas Limited
 202 – B, 2nd Floor, NRK Business Park,
 Vijay Nagar Square, A.B. Road,
 Indore (M.P), Pin – 452010

Dear Sir,

We _____ hereby authorize following representative(s) to attend Bid opening and for any other correspondence and communication against above Bidding Document:

Name & Designation _____ Signature _____

Name & Designation _____ Signature _____

We confirm that we shall be bound by all commitments made by aforementioned authorized representatives.

Yours faithfully,

Signature

Name & Designation

For and on behalf of

Note: This letter of authority should be on the letterhead of the bidder and should be signed by a person competent and having the power of attorney to bind the bidder.

Not more than two persons are permitted to attend techno –commercial un-priced and price bid opening.



E-Tender No.: AGL/Head Office/Contract and Purchase/22/25-26/ET/22
[METERING SKIDS]
ANNUAL RATE CONTRACT (02 YEARS) FOR SUPPLY OF METERING SKIDS



FORM – 6

NO DEVIATION CONFIRMATION

Aavantika Gas Limited
202 – B, 2nd Floor, NRK Business Park,
Vijay Nagar Square, A.B. Road,
Indore (M.P), Pin – 452010

Dear Sir,

We understand that any deviation / exception in any form may result in rejection of bid. We, therefore, certify that we have not taken any exceptions/deviations anywhere in the bid and we agree that if any deviation / exception is mentioned or noticed, our bid may be rejected.

(SEAL AND SIGNATURE OF BIDDER)



**E-Tender No.: AGL/Head Office/Contract and Purchase/22/25-26/ET/22
[METERING SKIDS]
ANNUAL RATE CONTRACT (02 YEARS) FOR SUPPLY OF METERING SKIDS**

FORM - 8

DETAILS OF SIMILAR WORK DONE DURING PAST SEVEN YEARS

Sr. No	Description of the work	Location of the work	Full Postal Address and phone nos. of Client & Name of Officer-in-Charge	Value of Contract	Date of Commencement of Work	Scheduled Completion Time (Months)	Date of Actual Completion	Reasons for delay in project completion, if any

Note: Copies of Letter of awards and completion certificate for the above works to be enclosed. The Work completed earlier than seven years need not be indicated here. The list of work, not of similar nature need not be indicated here Failing to comply aforementioned instructions may lead to rejection of bid.

SEAL AND SIGNATURE OF BIDDER



**E-Tender No.: AGL/Head Office/Contract and Purchase/22/25-26/ET/22
[METERING SKIDS]
ANNUAL RATE CONTRACT (02 YEARS) FOR SUPPLY OF METERING SKIDS**

FORM - 9

**PROFORMA FOR CONTRACT PERFORMANCE BANK GUARANTEE
(ON NON-JUDICIAL PAPER OF APPROPRIATE VALUE)**

Ref: Bank Guarantee No.....
Date.....

To
Aavantika Gas Limited
202 – B, 2nd Floor, NRK Business Park,
Vijay Nagar Square, A.B. Road,
Indore (M.P), Pin – 452010

Dear Sirs,

M/s _____ have been
awarded the work of (Specify Tender Name & No.),
vide POWO _____ No.
(Specify the PO / WO No.)
_____ for AAVANTIKA GAS

Ltd.,
202 – B, 2nd Floor, NRK Business Park, Vijay Nagar Square, A.B. Road, Indore (M.P.) India.

The Contracts conditions provide that the CONTRACTOR shall pay a sum of _____ (as full Contract Performance Guarantee in the form therein mentioned. The form of payment of Contract Performance Guarantee includes guarantee executed by Nationalized Bank, undertaking full responsibility to indemnify AAVANTIKA GAS Ltd., in case of default.

The said _____ (name of the contractor's firm) has approached us and at their request and in consideration of the premises we having our office at _____ have agreed to give such guarantee as hereinafter mentioned.

1. We _____ (name of the _____ Bank) _____ hereby undertake and agree with you that if default shall be made by M/s _____ in performing any of the terms and conditions of the tender or in payment of any money payable to AAVANTIKA GAS Ltd., we shall on demand pay without any recourse to the contractor to you in such manner as you may direct the said amount of _____ only or such portion thereof not exceeding the said sum as you may from time to time require.
2. You will have the full liberty without reference to us and without affecting this guarantee, postpone for any time or from time to time the exercise of any of the powers and rights conferred on you under the contract with the said _____ and to enforce or to forbear from endorsing any powers or rights or by reason of time being given to the said _____ which under law relating to the sureties would but for provision have the effect of releasing us.
3. Your right to recover the said sum of _____ (_____) from us in manner aforesaid will not be affected or suspended by reason of the fact that any dispute or disputes have been raised by the



**E-Tender No.: AGL/Head Office/Contract and Purchase/22/25-26/ET/22
[METERING SKIDS]
ANNUAL RATE CONTRACT (02 YEARS) FOR SUPPLY OF METERING SKIDS**

said M/s. _____ and/or that any dispute or disputes are pending before any officer, tribunal or court.

4. The guarantee herein contained shall not be determined or affected by the liquidation or winding up dissolution or changes of constitution or insolvency of the said but shall in all respects and for all purposes be binding and operative until payment of all money due to you in respect of such liabilities is paid.
5. This guarantee shall be irrevocable and shall remain valid upto _____, If any further extension of this guarantee is required, the same shall be extended to such required period on receiving instruction from M/s. _____ on whose behalf this guarantee is issued.
6. The Bank Guarantee's payment of an amount is payable on demand and in any case within 48 hours of the presentation of the letter of invocation of Bank Guarantee. Should the banker fail to release payment on demand, a penal interest of 18% per annum shall become payable immediately and any dispute arising out of or in relation to the said Bank Guarantee shall be subject to the jurisdiction of Indore Courts.
7. We have power to issue this guarantee in your favor under Memorandum and Articles of Association and the undersigned has full power to do under the Power of Attorney dated _____ granted to him by the Bank.

Yours faithfully,
_____ Bank

By its Constituted Attorney

Signature of a person duly authorized to sign on behalf of the Bank.



E-Tender No.: AGL/Head Office/Contract and Purchase/22/25-26/ET/22
[METERING SKIDS]
ANNUAL RATE CONTRACT (02 YEARS) FOR SUPPLY OF METERING SKIDS



INSTRUCTIONS FOR FURNISHING CONTRACT PERFORMANCE GUARANTEE

1. The Bank Guarantee by successful bidder(s) will be given on non-judicial stamp paper as per stamp duty applicable. The non-judicial stamp paper should be in name of the issuing bank. In case of foreign bank, the said bank guarantee to be issued by its correspondent bank in India on requisite non-judicial stamp paper and place of bid to be considered as Indore.
2. The bank guarantee by bidders will be given from bank as specified in ITB.
3. A letter from the issuing bank of the requisite Bank Guarantee confirming that said bank guarantee and all future communication relating to the Bank Guarantee shall be forwarded to Employer
4. If a bank guarantee is issued by a commercial bank, then a letter to Owner confirming its net worth is more than Rs.1,000,000,000/- (Rupees one hundred Crores) or its equivalent in foreign currency along with a documentary evidence.



E-Tender No.: AGL/Head Office/Contract and Purchase/22/25-26/ET/22
[METERING SKIDS]
ANNUAL RATE CONTRACT (02 YEARS) FOR SUPPLY OF METERING SKIDS



F-10

CERTIFICATE OF NON-INVOLVEMENT OF AGENT

Aavantika Gas Limited
202 – B, 2nd Floor, NRK Business Park,
Vijay Nagar Square, A.B. Road,
Indore (M.P), Pin – 452010

Dear Sir,

This is to certify that we have not engaged involve any Agent / Consultant / Retainer / Associate who is not an employee of _____ (name of your company) for payment of any remuneration thereof in India or abroad. Therefore, no Agent's / Representative's / consultant's commission is payable in India or abroad against this Contract.

SIGNATURE AND SEAL OF BIDDER

Notes:

1. This certificate should be issued in the Letter Head of the Bidder.
2. This certificate is to be issued only if there is no Agent / Consultant/ Retainer/ Associate is involved.



E-Tender No.: AGL/Head Office/Contract and Purchase/22/25-26/ET/22
[METERING SKIDS]
ANNUAL RATE CONTRACT (02 YEARS) FOR SUPPLY OF METERING SKIDS



F- 12

**DECLARATION
(ON BIDDER'S LETTER HEAD)**

Aavantika Gas Limited,

Indore (M.P.)

We confirm that we are not under any liquidation, court receiver ship or similar proceedings.

We also confirm that we have not been banned or de listed by any CGD Company for the tendered product/service.

**SEAL AND SIGNATURE OF BIDDER
(SIGNED BY COMPETENT AUTHORITY)**



E-Tender No.: AGL/Head Office/Contract and Purchase/22/25-26/ET/22
[METERING SKIDS]
ANNUAL RATE CONTRACT (02 YEARS) FOR SUPPLY OF METERING SKIDS



FORM – 13

DECLARATION ON TENDER DOCUMENT PURCHASED / DOWNLOADED
(on Bidder's letter head)

No. Date:

Aavantika Gas Limited, Indore (M.P.)

Sub: Bid Document no. AGL/Head Office/Contracts and Purchase/22/25-26/ET/22 [METERING SKIDS] for Supply of Metering skids ANSI 150# Single Filtration with By-pass, Corrigendum & Reply to bidder's queries etc.

Sir,

We hereby confirm that we have read each page of the subject Tender document along with Corrigendum & Reply to bidder's queries thoroughly and understood the complete Scope of Work and other terms & conditions. We hereby also confirm that tender terms & conditions are acceptable to us and entire scope of work shall be executed as per Project Timeline at the Quoted Rates without any deviation.

We also hereby confirm that we will comply to all Statutory Requirements without any price implication to AGL.

Yours faithfully, Signature
Name & Designation For and on behalf of

SEAL & SIGNATURE OF BIDDER

Bidder Seal & Sign

NATURAL GAS- CLEAN ENERGY, GREEN ENERGY



E-Tender No.: AGL/Head Office/Contract and Purchase/22/25-26/ET/22
[METERING SKIDS]
ANNUAL RATE CONTRACT (02 YEARS) FOR SUPPLY OF METERING SKIDS



SECTION VII

PACKING, MARKING AND SHIPPING

**PACKING, MARKING, SHIPPING AND DOCUMENTATION
SPECIFICATIONS FOR INDIGENOUS MATERIALS**

1.0 GENERAL

- 1.1 This specification forms an integral part of the relevant PURCHASE ORDER, in addition to the specifications, drawings and instructions explicitly listed in the PURCHASE ORDER.
- 1.2 Seller shall strictly comply with all applicable prescriptions in the specifications. Lack of relevant information and/or documents shall not absolve the SELLER of his responsibilities and any loss arising out of non-compliance shall be to supplier's account.

2.0 PROJECT

Name of PURCHASER, Project location and some other relevant information are as per Bid document / Annexure.

3.0 PACKING

- 3.1 The packing specifications incorporated herein are supplementary to the internal and external packing methods and standards as per current rules of IRCA goods tariff Part-I. All packing shall be done in such a manner so as to reduce volume as much as possible. Fragile articles should be packed with special packing materials depending on the type of materials.
- 3.2 Items shipped in bundles must be securely tied with steel wire or strapping. Steel reinforcing rods, bars, pipes, structural materials, etc. shall be bundled in uniform lengths and the weight shall be within the breaking strength of the securing wire or strapping.
- 3.3 All delicate surfaces on equipment/materials should be carefully protected and painted with protective paint/compound and wrapped to prevent rusting and damage.
- 3.4 All mechanical and electrical equipment and other heavy articles shall be securely fastened to the case bottom and shall be blocked and braced to avoid any displacement/shifting during transit.
- 3.5 Attachments and spare parts of equipment and all small pieces shall be packed separately in wooden cases with adequate protection inside the case and wherever possible should be sent along with main equipment. Each item shall be suitably tagged with identification of main equipment, item denomination and reference number of respective assembly drawing. Each item of steel structure and equipments shall be identified with two erection markings with minimum lettering height of 15 mm. Such marking will be followed by connection numbers in indelible ink/paint. A copy of the packing list shall accompany the material in each package.
- 3.6 All protrusions shall be suitably protected by providing a cover comprising of tightly bolted wooden discs on the flanges.
- 3.7 Wherever required, equipments/materials/instruments shall be enveloped in polyethylene bags containing silica gel or similar dehydrating compound.



**E-Tender No.: AGL/Head Office/Contract and Purchase/22/25-26/ET/22
[METERING SKIDS]
ANNUAL RATE CONTRACT (02 YEARS) FOR SUPPLY OF METERING SKIDS**



3.8 Pipes with threaded or flanged ends shall be protected with suitable caps / covers before packing.

3.9 Detailed packing list in waterproof envelope shall be inserted in the package together with equipment/material.

One copy of the detailed packing list shall be fastened outside the package in waterproof envelope and covered by metal cover.

3.10 The Seller shall be held liable for all damages or breakages to the goods due to the defective or insufficient packing as well as for corrosion due to insufficient protection.

3.11 Packaged equipment or material showing damage, defects or shortages resulting from improper packaging material or packing procedures or having concealed damage or shortages, at the time of unpacking shall be to the seller's account.

4.0 MARKING

4.1 Each package shall be marked on three sides with proper paints/indelible waterproof ink as follows:

PURCHASER

PROJECT

DESTINATION

Purchase Order No..... Net

Wt..... Kgs Gross W t..... Kgs.

Dimensions.....X.....X.....CM.

Package No. (Sl. No. of total packages).....

Seller's Name.....

4.2 Additional marking such as 'HANDLE WITH CARE', 'THIS SIDE UP', 'FRAGILE' or any other additional indications for protection and safe handling shall be added depending on the type of material.

- 4.3 Specific marking with paint for 'SLINGING and 'CENTRE OF GRAVITY' should be provided for all heavy lifts weighing 5 Tons and above.
- 4.4 In case of bundles/bags or other packages, wherever marking cannot be stenciled, the same shall be embossed on metal or similar tag and wired securely at two convenient points.

5.0 SHIPMENT

- 5.1 Dispatch of materials shall be made in accordance with the relevant terms of the Purchase Order. Any change in mode of transport shall be resorted to only after prior approval in writing. Seller shall ensure dispatch of equipments/materials immediately after they are inspected and released. All consignments shall be booked in the name of Purchaser and not under self-basis.

5.2 Dispatch By Road

- (a) The Seller shall be responsible for dispatch of materials on DOOR-DELIVERY basis through a reliable Bank-Approved transport company unless otherwise the transport company is named by PURCHASER.
- (b) The SELLER shall ensure with Transport Company the delivery of materials within a reasonable transit period. SELLER shall also obtain from transporter, particulars of Lorry Number, Transporter's Challan Number, destination of lorry (if transshipment is involved), Transporter's Agent at destination, if any, etc. and intimate same to Engineer In charge., AGL

5.3 Dispatch by Rail

- 5.3.1 The SELLER shall be responsible for:

- (a) Dispatch by the shortest possible route. The Seller shall as far as possible, Dispatch the materials by the fastest goods train like QTS, Super Express Goods, etc. wherever such facilities exist.
- (b) Correct classification of goods and freight charges.
- (c) Obtaining clean Railway Receipts without any qualifying remarks.

Should there be any restriction for movement by a particular route, the Railway authorities should be requested to move goods by the next alternative route, subject to prior consent of Engineer In charge, AGL.

5.3.2 As "SMALLS"

When the materials that do not make up a wagonload by weight/volume or for minimum freight payable for a wagon the Dispatch should be affected as "smalls".

SELLER should obtain from the Railway, the particulars of wagon in which the "Smalls" have been loaded, station at which sealed, train Number and date/time of movement and transmit the same to the Engineer In charge, for monitoring their movement.

5.3.3 As Wagon Loads

Consignments, though of lesser weight, but otherwise constituting a “wagon load” by volume should be dispatched as “wagon load” paying the freight applicable to a minimum wagon load or at the smalls rate, whichever is advantageous, as per Rule-164 of IRCA Goods Tariff Part-I (Vol.I).

When consignments call for full wagon(s), indents should be placed with the Railway Station concerned after predetermining accurately the type and number of wagons required. In case of covered wagons, it should be ensured that the same are watertight. If a particular type of wagon is in short supply, request should be made to the Railway Authorities to supply the next suitable type of wagon. Suitable packing in the wagon shall be done, wherever necessary, to ensure maximum safety of the material in transit.

When ODC packages are involved, the SELLER shall apply to the Railway Authorities with loading sketches showing overall dimensions and the wagon proposed to be utilized sufficiently in advance for obtaining movement sanction and to establish firm transportability. Copies of all such correspondence together with loading sketches should be sent to Engineer Incharge, AGL. ODC packages shall be loaded, packed and lashed strictly in accordance with the Railway Regulations. Should there be any delay/difficulty in obtaining the required wagon(s), the SELLER shall inform Engineer In charge, AGL immediately giving details of the required number of wagons, type, carrying capacity, etc. and indent number so that the matter may be taken up with the Railway Authorities concerned.

After Dispatch, SELLER shall obtain from the Railway Authorities, particulars of the wagon/train number, date of movement and destination junction for the particular train and furnish the same to the Engineer In charge, AGL for follow-up action on movement, as may be necessary.

After Dispatch of the equipment from dispatching station, if movement of the wagon is held-up due to improper/loose lashing resulting in shifting of the load and consignment is required to be readjusted / refixed the vendor shall be responsible to arrange for the same as per Railway requirements. Similarly, in case some infringement in dimensions of the loaded consignment is detected by Railway Authorities after its movement from dispatching station and if it is required to be corrected either by adjustment of the load or by cutting a few protrusions the same shall be arranged by vendor at their cost.

5.4 Shipment by Air

Wherever SELLER is instructed by PURCHASER to airfreight any material, the SELLER shall take prompt action for the same. Immediately after air shipment is effected, the Seller shall intimate by Fax / Email, the details of airway bill number and date, flight number, number of packages etc. to the Engineer In charge, AGL.

5.5 Destination

The consignments should be dispatched as indicated in bid document/Purchas Order.

5.6 Advance Information

Immediately after a shipment is made, SELLER shall send advance information as to the particulars of materials, value, Delivery Order Number, date of Dispatch, railway receipt number, wagon number/goods consignment note number, truck number, name of transport company and their destination office/associate's address etc./Airway Bill Number and flight details by way of Fax / E-Mail to Engineer In charge and Officer –



E-Tender No.: AGL/Head Office/Contract and Purchase/22/25-26/ET/22
[METERING SKIDS]
ANNUAL RATE CONTRACT (02 YEARS) FOR SUPPLY OF METERING SKIDS

C&P, AGL.



5.7 Transmission of Dispatch Documents

Seller shall, within 48 hours of the Dispatch of the material depending upon the payment terms of the Purchase Order, either negotiate through PURCHASER's Bankers or forward direct by Registered Post, the railway receipt/consignment note/Airway Bill to the Purchaser at project site accompanied by the original invoices, packing lists and challans.

The SELLER shall be responsible for any delay in clearance of the consignment at destination and consequent wharf age / demurrage, if any, due to delay in transmittal of the Railway Receipt, Consignment Note/Air Way Bill.

Copies of such Dispatch advise together with 2 copies of invoices and packing lists shall be simultaneously distributed to PURCHASER's (HO & Site).

6.0 TRANSIT RISK INSURANCE

All equipments/ materials will be insured for transit risk by PURCHASER unless otherwise specified. The Insurance cover will be provided from warehouse - to - warehouse.

7.0 DESPATCH THROUGH APPROVED TRANSPORTERS

All materials shall be dispatched through any bank approved transporter.

SECTION - VIII

SCHEDULE OF RATES

(SOR)

SCHEDULE OF RATES (SOR)					
LOT	Description	Quantity	Unit Price including packing and forwarding charges (such price to include all costs as well as duties and taxes paid or payable on components and raw materials incorporated or to be incorporated in the goods) including cost of Inspection by Third Party Agency, mandatory spares (wherever applicable), Freight Charges etc but excluding GST on finished goods		Total Amount Excluding GST in Rs.
		Nos.	Rs.		
LOT-1	2" Metering Skid ANSI 150# Single Filtration with Bypass	63	QUOTED	<input type="checkbox"/>	PLEASE DO NOT QUOTE RATES here against the SOR items in this given format. Only Mark Quoted or Not Quoted against this SOR
LOT-2	3" Metering Skid ANSI 150# Single Filtration with Bypass	3	NOT QUOTED	<input type="checkbox"/>	
LOT-3	4" Metering Skid ANSI 150# Single Filtration with Bypass	2			

Bidder to Quote GST (%): _____

**** The Quoted GST % shall be applicable on total quoted amount.**